



ED3M (Standard) Series AC Servo User Manual

Version: V1.00

ESTUN AUTOMATION TECHNOLOGY CO., LTD

— Total Solution Supplier



Revision History

No.	Date	Version	Description
1	Nov 20, 2018	V1.00	Initial release.

About this Manual

Purpose

This manual describes the following information required for designing and maintaining ED3M (Standard) Series AC Servo Drives.

- Specification of the Servodrives and Servomotors.
- Procedures for installing the Servodrives and Servomotors.
- Procedures for wiring the Servodrives and Servomotors.
- Procedures for operating of the Servodrives.
- Procedures for using the panel operator.
- Communication protocols.
- Ratings and characteristics.

Read and understand this manual to ensure correct usage of ED3M (Standard) Series AC Servo Drives.

Keep this manual in a safe place so that it can be referred to whenever necessary.

Intended Audience

This document is intended for:

- Those who designing ED3M (Standard) Series AC Servo Drives.
- Those who installing or wiring ED3M (Standard) Series AC Servo Drives.
- Those who performing trial operation or adjustments of ED3M (Standard) Series AC Servo Drives.
- Those who maintaining or inspecting ED3M (Standard) Series AC Servo Drives.





Technical Terms

The following terms are used in this manual.

Term	Meaning
Servomotor	An EM3A Series or EMG Series Rotary Servo Motor.
Servodrive	An ED3M (Standard) Series AC Servo Drive, which is used for controlling the motion of Rotary Servo Motor.
Servo System	A servo control system that includes a Seromotor, a Servodrive with a host controller and peripheral devices.
Servo ON	Supplying power to the motor.
Servo OFF	Not supplying power to the motor.

Symbol Conventions

The symbols that may be found in this document are defined as follows.

Symbol	Description
 DANGER	Indicates a hazard with a high level of risk that, if not avoided, will result in death or serious injury.
 WARNING	Indicates a hazard with a medium or low level of risk which, if not avoided, could result in minor or moderate injury.
 CAUTION	Indicates a potentially hazardous situation that, if not avoided, could cause equipment damage, data loss, and performance degradation, or unexpected results.
 IMPORTANT	Indicates precautions or restrictions that must be observed. Also indicates alarm displays and other precautions that will not result in machine damage.
 NOTE	Provides additional information to emphasize or supplement important points of the main text.

The names of reverse signals (i.e., ones that are valid when low) are written with a forward slash (/) before the signal abbreviation. For example:

$\overline{\text{S-ON}}$ is written as /S-ON; $\overline{\text{P-CON}}$ is written as /P-CON.

The names of sub-parameters are written as the format of Pnxxx.x. The following takes the parameter Pn000 as an example, whose sub-parameters Pn000.0, Pn000.1, Pn000.2 and Pn000.3 corresponding to one bit of its value respectively.

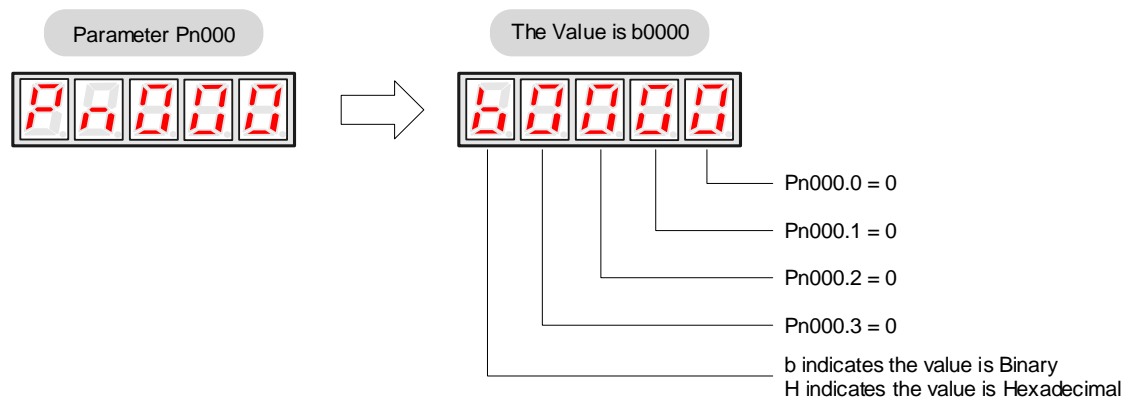

Safety Precautions



- Never connect the Servomotor directly to the local electrical network.
 - Never plug or unplug connectors from the Servodrive when power is on.
 - Wait for five minutes after turning OFF the power supply and then make sure that the CHARGE indicator is not lit before starting wiring or inspection work.
Never touch the power supply terminals while the CHARGE lamp is lit after turning OFF the power supply, because high voltage may remain in the Servodrive.
-



- Provide at least 10mm space between the Servodrives and the control panel or with other devices. In addition, the longitudinal space between them are above 50mm. Whenever possible, choose a layout that is conducive to heat dissipation. and the installation environment is not affected by condensation, vibration or shock.
 - Install a high-sensitivity Ground Fault Detector against overloads and short-circuiting.
 - Never perform any extreme adjustments or settings.
 - Always start or stop the Servomotor by using reference pulses. Never operate the Servomotor by turning the power ON and OFF.
 - Always match the proper encoder for each Servomotor.
 - Check and confirm that the cables for each Servomotor has been properly connected to the Servodrive.
-



Comply with the following instructions to avoid noise generated by signal lines.

- Separate high-voltage cables from low-voltage cables.
 - Use cables as short as possible.
 - Connect the ground terminals on the Servodrive and Servomotor to ground poles according to local electrical codes (100 Ω or less).
 - Never use a line filter for the power supply in the circuit.
-

Contents

Revision History	i
About this Manual	i
Purpose.....	i
Intended Audience	i
Technical Terms	i
Symbol Conventions.....	ii
Safety Precautions	iii
Contents	i
Chapter 1 Basic Informations on Product	1
1.1 Checking Products	1
1.1.1 Servomotor	1
1.1.2 Servodrive	3
1.2 Part Names	4
1.2.1 Servomotor	4
1.2.2 Servodrive	4
Chapter 2 Installation	5
2.1 Servomotor.....	5
2.1.1 Conditions	5
2.1.2 Coupling to the Machine	6
2.2 Servodrive	8
Chapter 3 Wiring	11
3.1 Main Circuit Wiring.....	11
3.1.1 Names and Functions	11
3.1.2 Wiring Example.....	12
3.2 Inputs and Outputs	13
3.2.1 Wiring Example.....	13
3.2.2 Terminal Layout	14
3.2.3 Names and Functions	15
3.2.4 I/O Circuits.....	16
3.3 Encoder Wiring	17
3.3.1 Wiring Diagram.....	17
3.3.2 Terminal Layout	18
3.4 Communication Wiring.....	18
3.5 Wiring for Noise Control	19
3.5.1 Noise Control	19
3.5.2 Precautions on Connecting Noise Filter	20
Chapter 4 Panel Operator	23
4.1 Basic Operation.....	23
4.1.1 Functions on Panel Operator	23
4.1.2 Axis Switching	23
4.1.3 Mode Switching	23
4.2 Status Display	24
4.3 Operation in Parameter Setting Mode.....	25
4.4 Operation in Monitor Mode	26
4.5 Operation in Utility Function Mode.....	27
4.5.1 Alarm Traceback Data Display.....	28
4.5.2 Parameter Settings Initialization.....	28

4.5.3 JOG Operation.....	29
4.5.4 Offset Adjustment for Current Detection	30
4.5.5 Software Version Display	31
4.5.6 Position Teaching Function	31
4.5.7 Moment of Inertia Estimation	32
4.5.8 Parameters Copying	32
Chapter 5 Operation without CANopen	33
5.1 Trial Operation	33
5.1.1 Flow of Trial Operation.....	33
5.1.2 Trial Operation for Servomotor Without Load	35
5.1.3 Trial Operation for Servomotor without Load from Host Controller	36
5.1.4 Trial Operation with the Servomotor Connected to the Machine	38
5.1.5 Trial Operation for Servomotor with Brakes	38
5.2 Control Method Setting.....	39
5.3 Basic Functions Setting	39
5.3.1 Servo ON.....	39
5.3.2 Rotation Direction	40
5.3.3 Overtravel.....	41
5.3.4 Holding Brakes Setting	43
5.4 Absolute Encoders	46
5.4.1 Absolute Encoder Selection.....	46
5.4.2 Handling Battery	46
5.4.3 Replacing Battery	47
5.4.4 Absolute Encoder Setup (Fn010, Fn011).....	47
5.5 Speed Control.....	48
5.5.1 Parameter Setting	48
5.5.2 Soft Start.....	48
5.5.3 Speed Reference Filter Time Constant	49
5.5.4 S-curve Risetime	49
5.5.5 Speed coincidence output.....	49
5.5.6 Speed control (contact reference)	50
5.6 Position Control	51
5.6.1 Parameter Setting	51
5.6.2 Clear Setting.....	54
5.6.3 Electronic Gear Setting	54
5.6.4 Smoothing	57
5.6.5 Low Frequency Vibration Suppression	58
5.6.6 Positioning Completion Output Signal.....	60
5.6.7 Reference Pulse Inhibit Function(INHIBIT).....	60
5.6.8 Position Control (contact reference).....	61
5.6.9 Internal Homing Function	63
5.7 Torque Limit	66
5.7.1 Internal Torque Limit	66
5.7.2 External Torque Limit	67
5.8 Other Output Signals.....	68
5.8.1 Servo alarm output	68
5.8.2 Others	69
5.9 Online Autotuning.....	70
5.9.1 Function Description	70
5.9.2 Online Autotuning Procedure.....	71
5.9.3 Setting Online Autotuning.....	72
5.9.4 Machine Rigidity Setting for Online Autotuning	72
Chapter 6 CANopen Communication	73
6.1 Wiring and Connection	73
6.2 Messages Description	73
6.2.1 CAN identifier list.....	74
6.2.2 SDO.....	75
6.2.3 PDO.....	77

6.2.4 SYNC Message	84
6.2.5 Emergency Message.....	85
6.2.6 HEARTBEAT Message.....	87
6.2.7 Network management (NMT service).....	88
6.3 Conversion Factors (Factor Group)	89
6.3.1 Relevant parameters	90
6.3.2 Position factor	90
6.3.3 Velocity factor	91
6.3.4 Acceleration factor	92
6.4 Position Control Function	93
6.4.1 Following error)	94
6.4.2 Position Reached.....	94
6.4.3 Relevant Parameters	95
6.5 State machine.....	97
6.6 Relevant Parameters of Device Control.....	98
6.6.1 Controlword	99
6.6.2 Statusword.....	100
6.6.3 Shutdown_option_code.....	102
6.6.4 Disable_operation_option_code.....	102
6.6.5 Quick_stop_option_code.....	103
6.6.6 Halt_option_code.....	104
6.6.7 Fault_reaction_option_code.....	104
Chapter 7 CANopen Control Mode.....	105
7.1 Relevant Parameter of Control Mode	105
7.1.1 Modes_of_operation.....	105
7.1.2 Modes_of_operation_display	106
7.2 Homing Mode	106
7.2.1 Control Word.....	106
7.2.2 Status Word	106
7.2.3 Relevant parameter.....	107
7.2.4 Homing Sequences.....	111
7.3 Profile Velocity Mode	117
7.3.1 Flow Diagram.....	117
7.3.2 Control word	117
7.3.3 Status word.....	117
7.3.4 Relevant Parameters	118
7.4 Profile Torque Mode	122
7.4.1 Flow Diagram.....	122
7.4.2 Control Word.....	122
7.4.3 Status Word	122
7.4.4 Relevant Parameters.....	123
7.5 Profile Position Mode	125
7.5.1 Flow diagram	125
7.5.2 Control Word.....	125
7.5.3 Status word.....	126
7.5.4 Relevant Parameters	126
7.5.5 Function description.....	129
7.6 Interpolation Position Mode	132
7.6.1 Flow Diagram.....	132
7.6.2 Control Word.....	132
7.6.3 Status word.....	132
7.6.4 Relevant Parameters	133
7.6.5 Function description.....	136
7.7 Torque limit Function.....	137
Chapter 8 CANopen Configuration Example.....	138
8.1 SDO configuration.....	138
8.2 PDO Configuration	138

8.3 Profile Position Mode	138
8.4 Two-axis interplate position mode	139
8.5 Homing	141
Chapter 9 MODBUS Communication.....	142
9.1 RS-485 Wiring	142
9.2 Relevant Parameters for MODBUS	143
9.3 MODBUS Protocol.....	143
9.3.1 Code Meaning	143
9.3.2 Data Format.....	145
9.3.3 Communication Exception	149
9.3.4 Data Communication Address in Servodrive	150
Chapter 10 Specifications and Dimension.....	153
10.1 Servodrive Specifications	153
10.2 Servodrive Dimension	154
Appendix A Parameters List	155
A.1 Interpreting the Parameters List	155
A.2 List of Servo Parameters	156
Appendix B Alarms List.....	185
Appendix C Object dictionary.....	187

Chapter 1 Basic Informations on Product

1.1 Checking Products

Check Items	Comments
Are the delivered products theones that were ordered?	Check the model numbers marked on the nameplate on theservomotor and servo drive.
Is there any damage?	Check the overall appearance, and check for damage or scratches that may have occurred during shipping.
Does the servomotor shaft rotate smoothly?	The servomotor shaft is normal if it can be turned smoothly by hand. Servomotors with brakes, however, cannot be turned manually.

<NOTE>: If any of the above items are faulty or incorrect, contact your ESTUN representative or the dealer from whom you purchased the products.

1.1.1 Servomotor

Nameplate Example

The following figure shows the nameplate of EMJ model Servomotor as an example. Nameplates of the EML model and EMG model are similar.

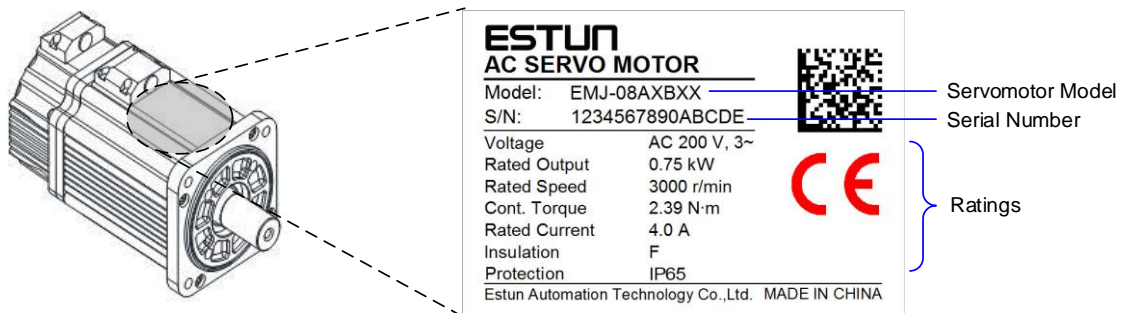

Model Designations

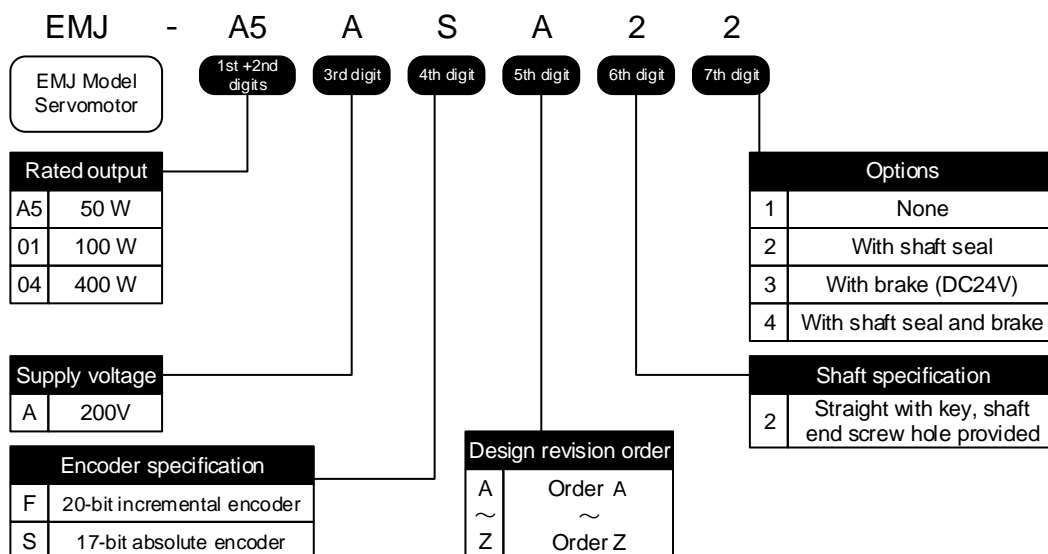

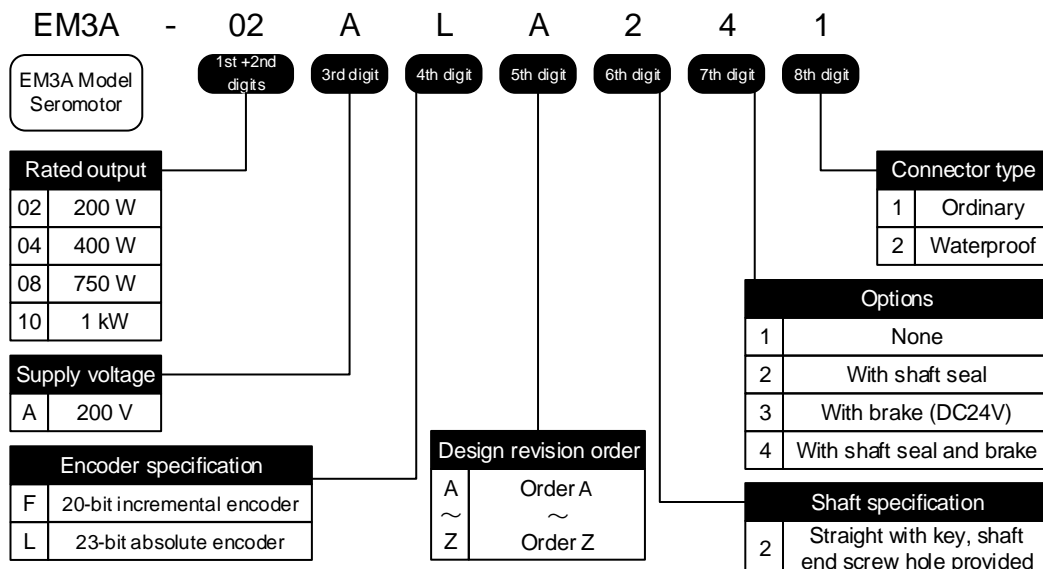
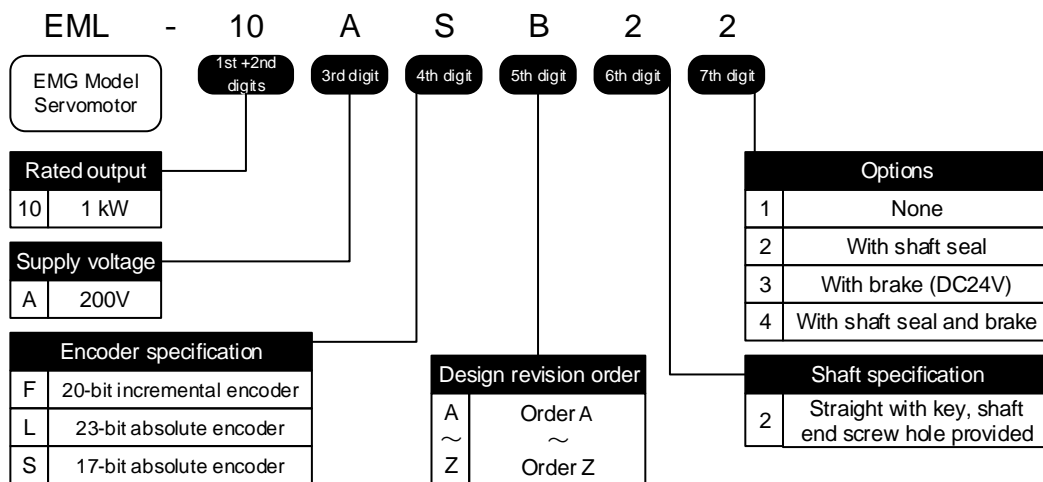
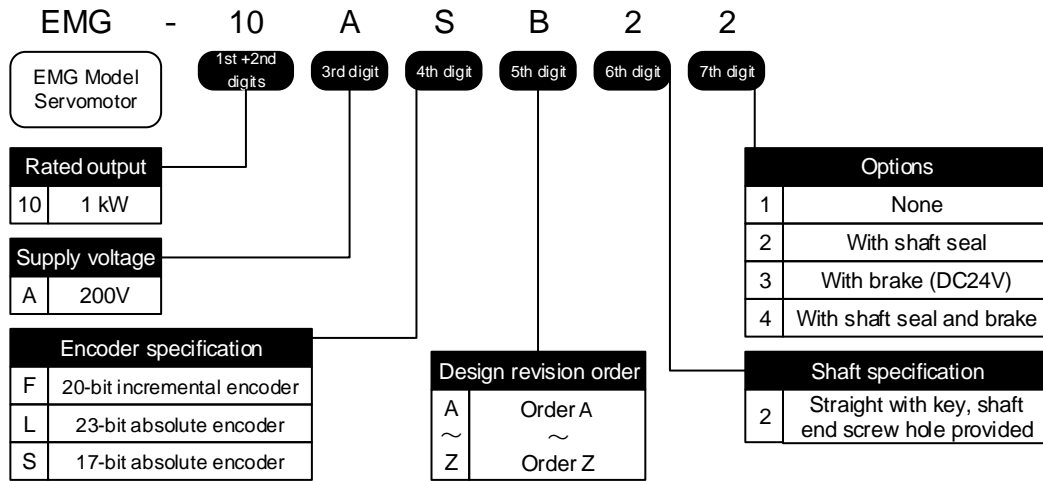

1.1.2 Servodrive

Nameplate Example

The following figure shows the nameplate of ED3M model Double-Axis Servodrive as an example. The nameplate of the ED3M model Treble-Axis Servodrive is similar.

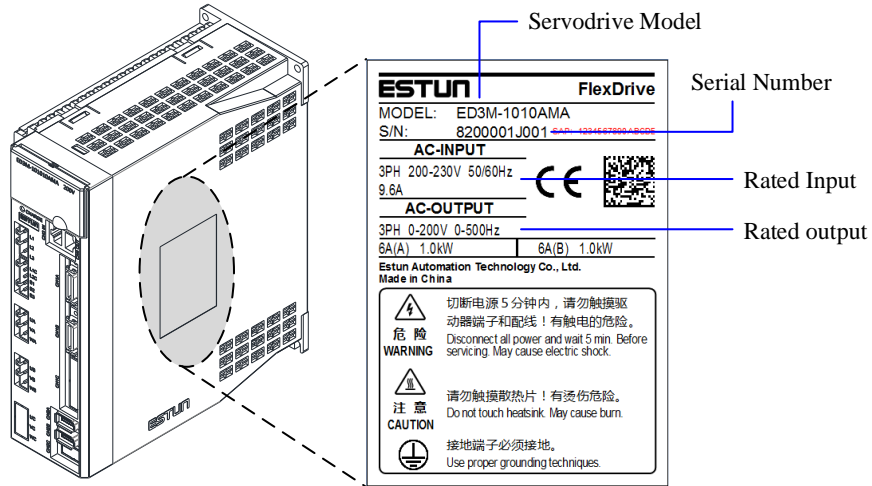

Model Designations

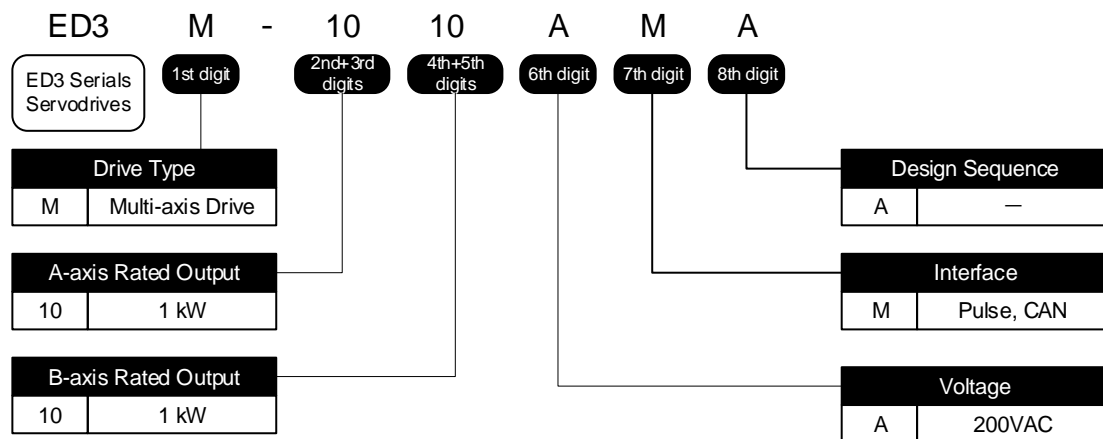
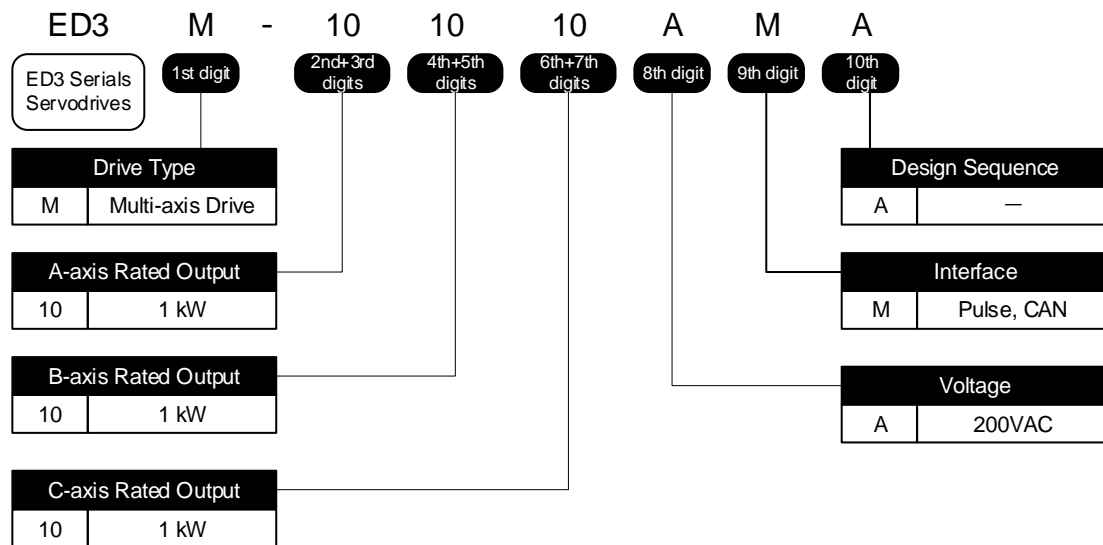

[NOTE] All the axis of ED3M servodrive controlled can be applied for the motor power of 50W to 1kW, those also can be set up to treble in overload capability.

1.2 Part Names

1.2.1 Servomotor

The following figure shows the part names of EMJ model Servomotor as an example. The part names of the EML model and EMG model Servodrives are similar.

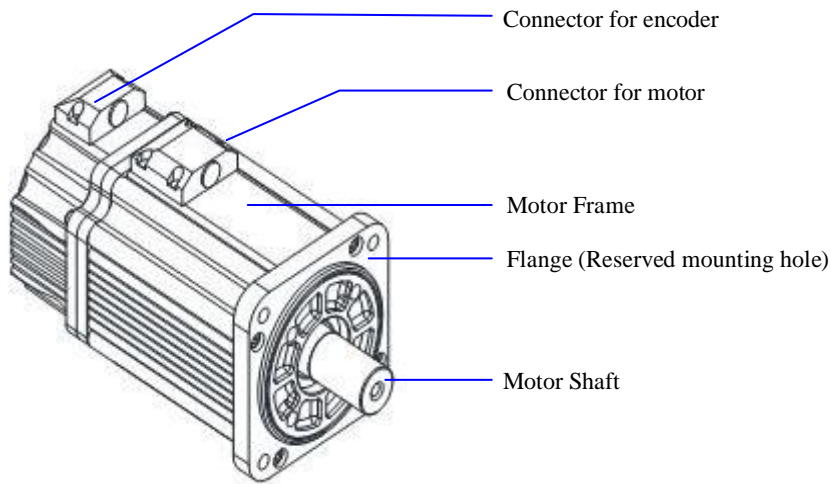

1.2.2 Servodrive

The following figure shows the part names of ED3M model Double-Axis Servodrive as an example. The part names of the ED3M model Treble-Axis Servodrive is similar.

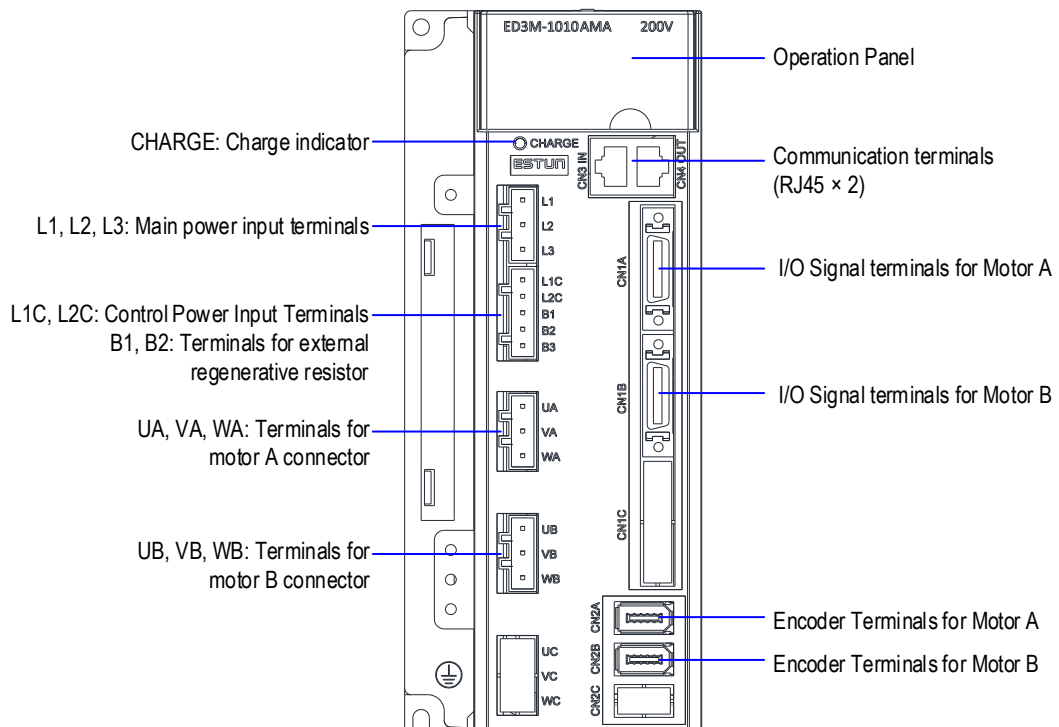

Even if you turn OFF the main circuit power supply, the CHARGE indicator will be lit as long as the internal capacitor remains charged. Never touch the main circuit or motor terminals while this indicator is lit, to avoid the electric shock.

Chapter 2 Installation

2.1 Servomotor

Anticorrosive paint is coated on the edge of the motor shaft to prevent it from rusting during storage. Clean off the anticorrosive paint thoroughly using a cloth moistened with thinner before installing the motor.

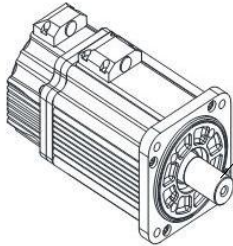

Anticorrosive paint is coated here

2.1.1 Conditions

Storage

When the Servomotor is to be stored with the power cable disconnected, store it in the following temperature range:

Between -20 and 60°C.

Installation Sites

The servomotor is designed for indoor use. Install the servomotor in an environment which meets the following conditions:

- Free from corrosive and explosive gases.
- Well-ventilated and free from dust and moisture.
- Ambient temperature of 0 to 40°C.
- Relative humidity of 26% to 80% (non-condensing).
- Inspection and cleaning can be performed easily.

Installation Orientation

You can install the Servomotor either horizontally or vertically.

However, you shall install the Servomotor according to the actual use of the machine, which makes the motor work best with the machine for ensuring the service life of the Servomotor or avoiding accidents.

Using Servomotors with Holding Brakes

This section gives precautions for using Servomotors with Holding Brakes.

- The holding brakes have a limited service life. Although the quality and reliability of a holding brake has been sufficiently confirmed, stress factors, such as emergency braking, can result in problems in the holding operation. In applications in which safety is a concern, such as for a load falling on a vertical axis, determine if safety measures are required on the machine, such as adding a redundant fall-prevention mechanism.
- For a Servomotor with a Holding Brake, there is a small amount of rotational play in the motor shaft (1.5° max. initially) because of the backlash in the holding brake, even when the brake power is OFF.

- For a Servomotor with a Holding Brake, the brake's rotating disc may sometimes generate murmur from friction during acceleration, stopping, and low-speed operation.

Using Servomotors with Oil Seals

This section gives the operating conditions for using Servomotors with Oil Seals.

- Keep the oil surface below the oil seal lip.

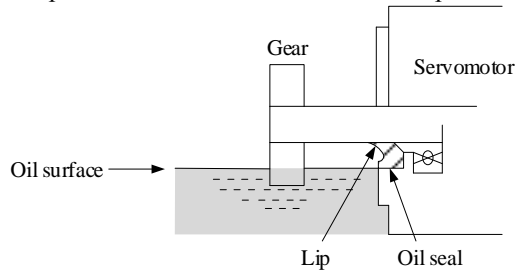

- Use the oil seal in favorably lubricated condition with only splashing of oil.
- Never let the oil collect in the oil seal lip.
- Never use the Servomotor where the oil seal would be below the oil surface. If you do, oil will enter the Servomotor, which may damage the Servomotor.

2.1.2 Coupling to the Machine

For instilling the motor to the client, connect the motor with the load via the reserved mounting hole by using screws with spring washers.

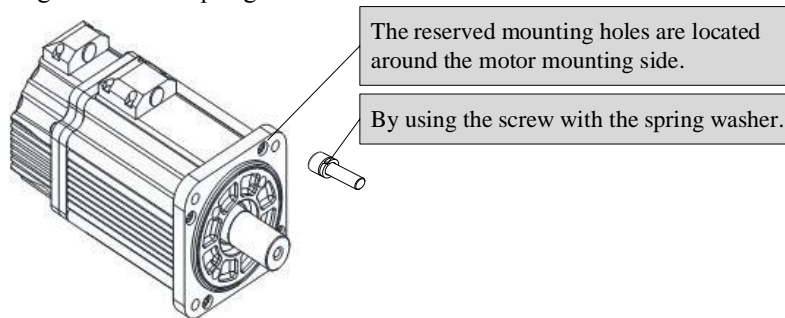

Using a Coupling



IMPORTANT

- Use a flexible coupling that is designed for Servomotors.
- Select a suitable size of coupling for the operating conditions. An inappropriate coupling may cause damage.

1. Wipe off all of the anticorrosive coating from the motor shaft.
2. If you are using a Servomotor with a Key, attach the key enclosed with the Servomotor or the specified size of key to the shaft.
3. Confirm that the centering accuracy is within the specified range using a dial gauge or other means. If a dial gauge is not available, slide the coupling along both shafts and make adjustments so that it does

not catch.

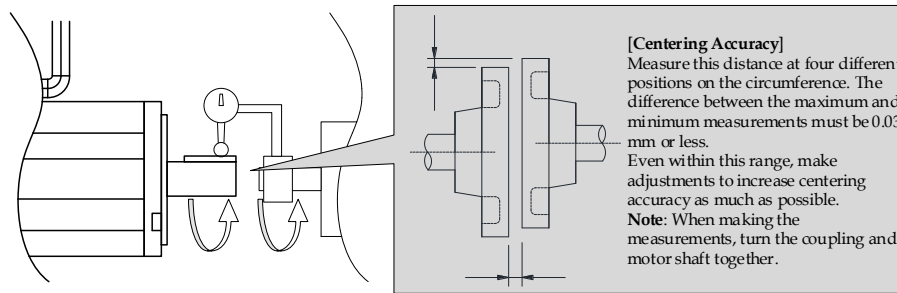

4. Align the shaft of the Servomotor with the shaft of the machine, and then connect the shafts with the coupling.

- When you couple the shafts, make sure that the required centering accuracy is achieved. Vibration will damage the bearings and encoders if the shafts are not properly centered.
- When you attach the coupling, do not subject the shaft to direct shock. Also, do not subject the area around the encoder to shock. Shock may damage the encoder.

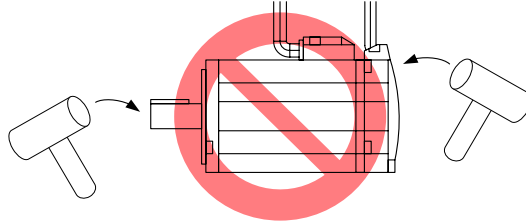

- If the coupling makes any abnormal noise, center the shafts again until the noise is eliminated.
- Make sure that the thrust load and radial load are within specifications. Refer to the specifications for each type of Servomotor for the thrust load and radial load.

Using a Belt



IMPORTANT

Select a coupling belt that is suitable for the allowable radial load of the Servomotor and the Servomotor output.

When the Servomotor accelerates or decelerates, the counterforce from the acceleration/deceleration torque adds tension to the initial belt tension. Take this additional tension into consideration when you select the coupling belt.

1. Wipe off all of the anticorrosive coating from the motor shaft.
2. If you are using a Servomotor with a Key, attach the key enclosed with the Servomotor or the specified size of key to the shaft.
3. If you need to attach a pulley to the Servomotor with a Key, use a screwdriver to tighten the screw in the end of the motor shaft to press in and attach the pulley.

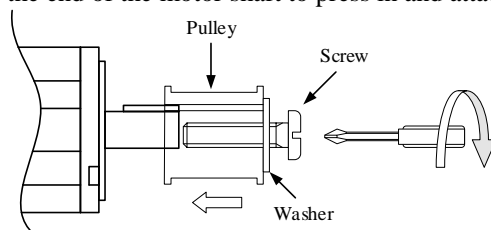

4. Couple the Servomotor to the machine with a belt.
When you attach the belt, adjust the belt tension so that the allowable radial load given in the Servomotor

specifications is not exceeded. For details, refer to the catalog of the belt manufacturer.

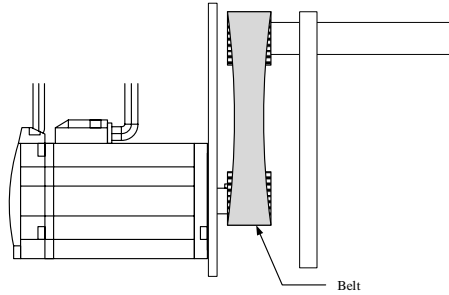

Adjust the belt tension to adjust the radial load. Measure the belt tension at 45° intervals of the machine shaft. Turn the shaft and take measurements with a belt tension meter at each point.

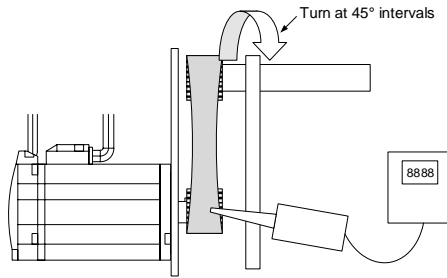

2.2 Servodrive

Storage

When the Servomotor is to be stored with the power cable disconnected, store it in the following temperature range:
Between -20 and 85°C.

Environmental Conditions

- Ambient temperature is from 0°C to 55°C.
- Ambient humidity is low than 90%RH, and free from condensation.
- Vibration is low than 4.9m/s².
- It is recommended the ambient temperature shall be below 45°C to ensure the stable operation.

Installation Sites

The following table lists some precautions on installation sites.

Situation	Precautions on Installation
When installed in a control panel	Design the control panel size, unit layout, and cooling method so that the temperature around the periphery of the Servodrive shall not more than 55°C.
When installed near a heating unit	Suppress radiation heat from the heating unit and a temperature rise caused by convection so that the temperature around the periphery of the Servodrive shall not more than 55°C.
When installed near a source of vibration	Install a vibration isolator underneath the Servodrive to prevent it from receiving vibration.
When installed in a place receiving corrosive gases	Corrosive gases do not immediately affect the Servodrive but will eventually cause contactor-related devices to malfunction. Take appropriate action to prevent corrosive gases.

Situation	Precautions on Installation
Others	Avoid installation in a hot and humid place or where excessive dust or iron powder is present in the air.

Mounting Orientation

As is shown in the following figure, the Servodrive is installed perpendicular to the base.

Prepare two mounting holes for the Servodrive and mount it securely in the mounting holes. In addition, let the front panel of the Servodrive is facing toward the operator.

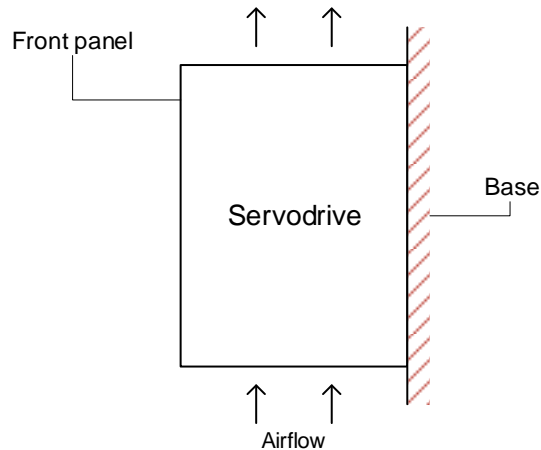

A fan can be added to force cooling the Servodrive if necessary.

Mounting Interval

- When you install one Servodrive in the control panel, provide the following spaces around the Servodrive.

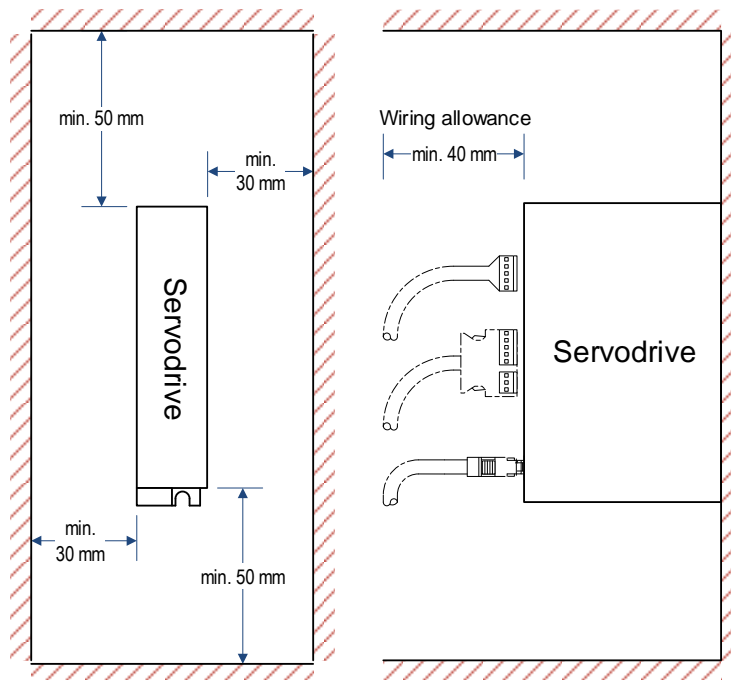

- When you install more than one Servodrive in the control panel, provide the following intervals between the Servodrives and spaces around the Servodrives. Install cooling fans above the Servodrives so that hot spots do not occur around the Servodrives. Provide sufficient intervals and spaces as shown in the following figure to enable cooling by the fans

and natural convection.

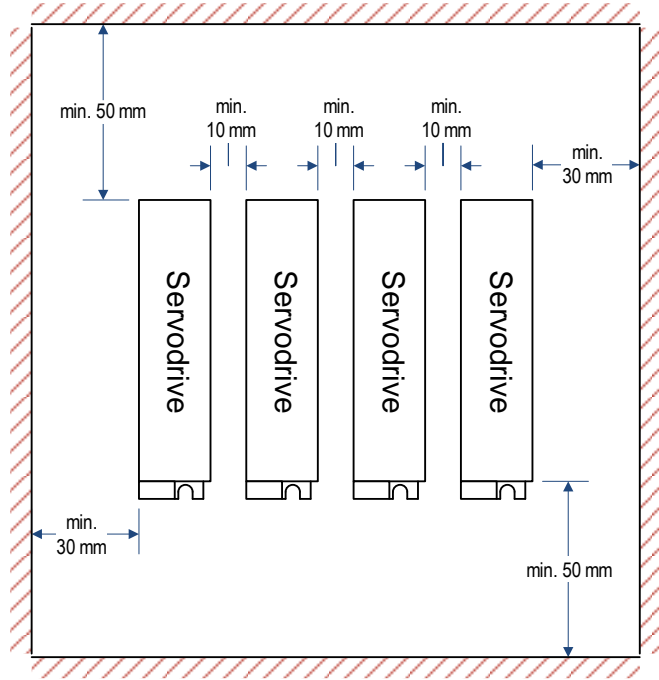

Chapter 3 Wiring

3.1 Main Circuit Wiring



Please observe the following precautions when wiring.

- Never bundle or run power and signal lines together in the same duct. Keep power and signal lines separated by at least 300 mm.
- Use twisted-pair shielded wires or multi-core twisted-pair shielded wires for signal and encoder feedback lines.
- The maximum length is 3 m for reference input lines and 20 m for encoder feedback lines.
- Never touch the power terminals for 5 minutes after turning power OFF because high voltage may still remain in the servo drive.

3.1.1 Names and Functions

Symbol	Name	Functions
L1, L2, L3	Main circuit power supply input terminal	Three-phase 200 VAC to 230 VAC, -15% to +10%, 50 Hz or 60 Hz
U_A, V_A, W_A	Servomotor terminals for axis A	Connect to the Servomotor of axis A.
U_B, V_B, W_B	Servomotor terminals for axis B	Connect to the Servomotor of axis B.
U_C, V_C, W_C	Servomotor terminals for axis C	Connect to the Servomotor of axis C.
L1C, L2C	Control power supply terminals	Single-phase 200 VAC to 230 VAC, -15% to +10%, 50 Hz or 60 Hz
⏚	Ground terminals	Connects to the power supply ground terminals and servomotor ground terminal.
B1, B2, B3	External regenerative resistor connection terminal	If using an internal regenerative resistor, please short B2 and B3. Remove the wire between B2 and B3 and connect an external regenerative resistor (provided by customer) between B1 and B2, if the capacity of the internal regenerative resistor is insufficient.

3.1.2 Wiring Example

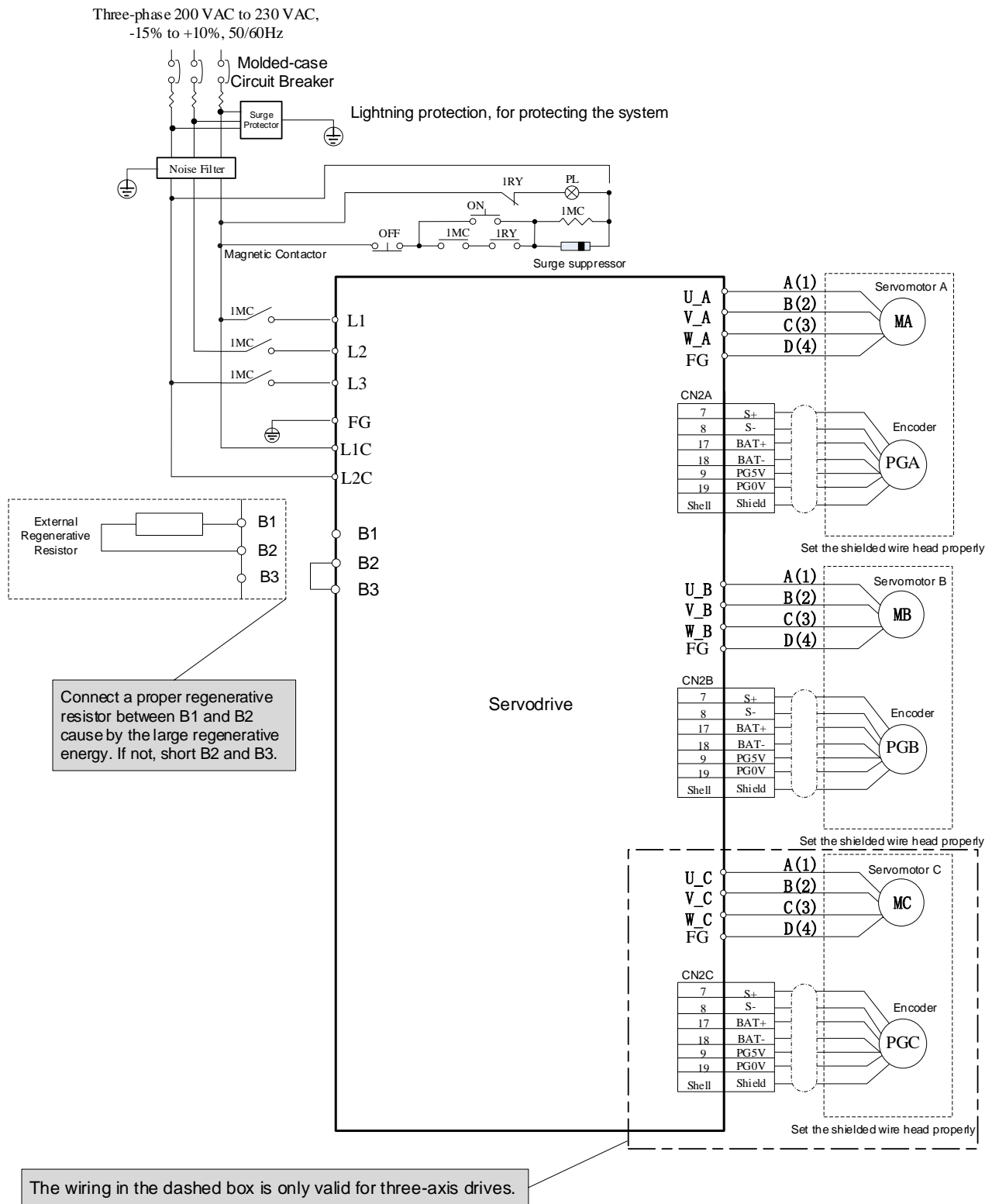

3.2 Inputs and Outputs

3.2.1 Wiring Example

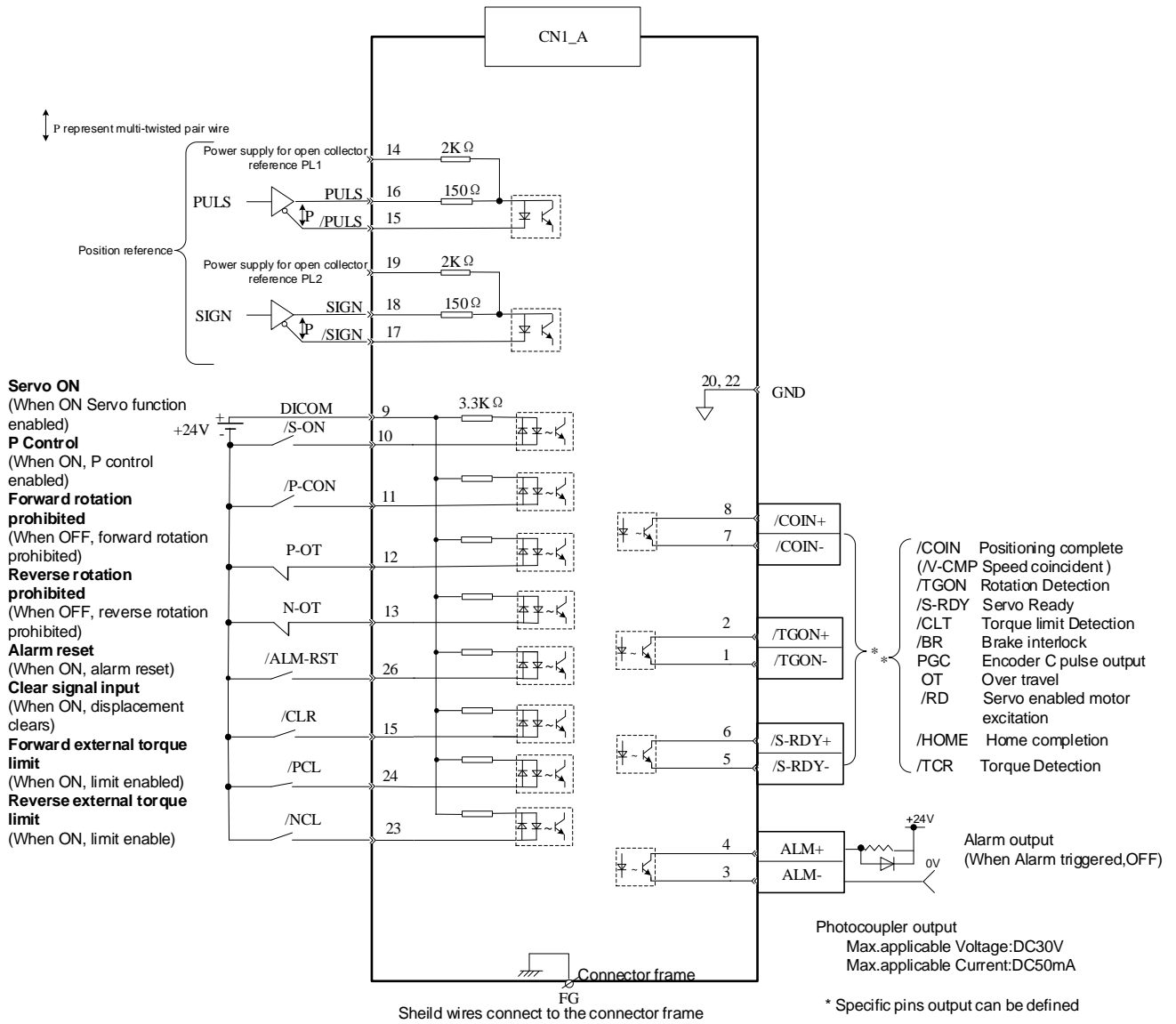

- The wirings of CN1A, CN1B and CN1C are the same.
- The signal names mentioned in the figure for the I/O ports are all defined by the factory setting values. See the **Appendix A Parameters List** for reallocated them.

3.2.2 Terminal Layout

Pin No.	Name	Description
1	0: /COIN(/VCMP)	0: Positioning completion (speed agree detection)
2	1: /TGON	1: Running signal output
5	2: /S-RDY	2: Servo ready
6	3: /CLT	3: Torque limit output
7	4: /BK	4: Brake interlock output
8	5: PGC	5: C pulse output
	6: OT	6: Over travel signal output
	7: /RD	7: Servo enabled motor excitation output
	8: /HOME	8: Home completion output
	9: /TCR	9: Torque detection output
3	ALM-	Servo alarm: Turns off when an error is detected.
4	ALM+	
9	DICOM	Control power supply input for I/O signals: Provide the +24V DC power supply
10	0: /S-ON	0: Servo ON
11	1: /P-CON	1: P/PI control input
12	2: P-OT	2: Forward run prohibited
13	3: N-OT	3: Reverse run prohibited
23	4: /ALM-RST	4: Alarm reset
24	5: /CLR	5: Position error pulseclear input
25	6: /PCL	6: Forward torque limitinput
26	7: /NCL	7: Reverse torque limitinput
	8: /G-SEL	8: External switch gain switching
	9: /JDPOS-JOG+	9: Position control (contact reference) -forward direction JOG
	A: /JDPOS-JOG-	A: Position control (contact reference) -reverse direction JOG
	B: /JDPOS-HALT	B: Position control (contact reference) -stop JOG
	C: Reserved	C: Reserved
	D: SHOME	D: Hometrigger
	E: ORG(ZPS)	E: Zero position
14	PPIP	Collector open circuit power supply
19	PPIS	
15	PULS-	Pulse signal
16	PULS+	
17	SIGN-	Direction signal
18	SIGN+	
20, 22	GND	Digital Ground
Shell	FG	Frame Ground



NOTE

- The list of CN1A, CN1B and CN1C about I/O Signal Names and Functions are the same.
- Spare terminals can not be used for relay purpose.
- Connect shielded cable wires of I/O signals to connector shell (frame ground).

3.2.3 Names and Functions

Name	Terminal No.	Function	
DICOM	9	Control power supply input for I/O signals: Provide the +24V DC power supply.	
/S-ON	10	Servo ON: Turns the servomotor on.	The function of I/O are default, it can be changed by setting parameters.
/P-CON	11	It has deferent means depends on deferent control mode.	
P-OT	12	Forward run prohibited	
N-OT	13	Reverse run prohibited	
/ALM-RST	26	Alarm reset: Releases the servo alarm state.	
/CLR	25	Positional error pulse clear input: Clear the positional error pulse during position control.	
/PCL	24	Forward external torque limit	
/NCL	23	Reverse external torque limit	
PPIP	14	Power supply input for open collector reference (pulse)	
PPIS	19	Power supply input for open collector reference (direction)	
PULS-	15	Reference pulse input Reference sign input	Pulse reference input mode: <ul style="list-style-type: none"> • Sign + pulse train • CCW + CW pulse • Two-phase pulse
PULS+	16		
SIGN-	17		
SIGN+	18		
/COIN- (/V-CMP-)	7	Positioning completion(Speed coincidence): Turns ON when the number of positional error pulses reaches the value set.	The functions of I/O are default; you can change them by setting parameters.
/COIN+ (/V-CMP+)	8		
/TGON-	1	Motor rotation detection: when the servomotor is rotating at a speed higher than the motor speed setting.	
/TGON+	2		
/S-RDY-	5	Servo ready: turn ON if there is no servo alarm when the control/main circuit power supply is turned ON.	
/S-RDY+	6		
ALM-	3	Servo alarm: Turns off when an error is detected.	
ALM+	4		
GND	20, 22	Grounding	
FG	Shell	Connect frame to ground if the shield wire of the I/O signal cable is connected to the connector shell.	

3.2.4 I/O Circuits

Sequence Input Circuits

Examples for Relay Circuits and Open-Collector Circuits are as shown in the following figure.

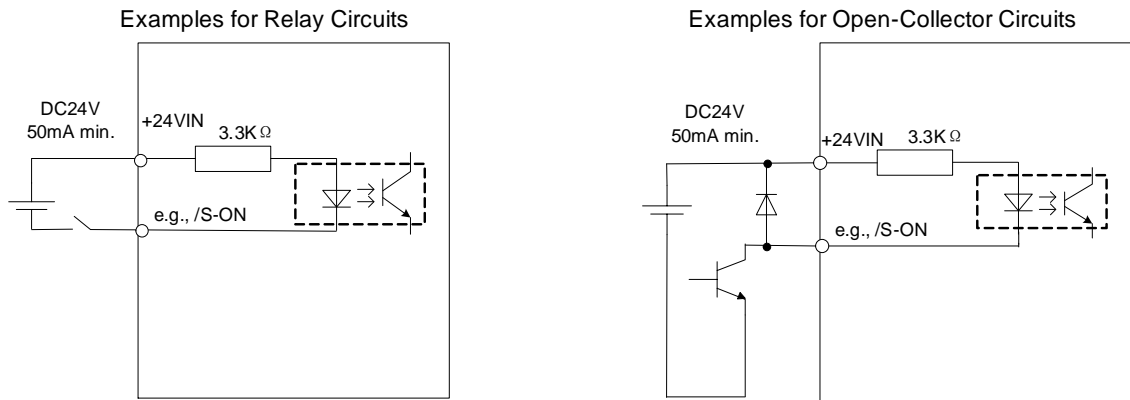

Select a low-current relay for the relay circuits, or a faulty contact may be caused.

Encoder Output Circuits

The signals of the encoder pulses (PAO+, PAO-, PBO+, PBO-) and origin signal pulses (PCO+, PCO-) are output by the bus drive circuits. The circuits are usually used in the host controller for forming a position control system, which connects a encoder output circuit to line-receiver circuit.

For details about the encoder circuit, see the section 3.3 Encoder Wiring.

Sequence Output Circuits

Photocoupler output circuits are used for the ALM (Servo Alarm), /P-CON (Position Completed), /BK (Brake Interlock) and other sequence output signals.

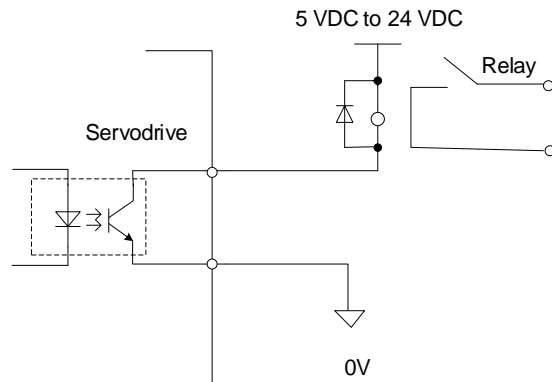

The maximum allowable voltage and current range for photocoupler output circuits are as follows:

- Maximum allowable voltage: 30 VDC
- Current range: 5 mA to 50 mA DC

3.3 Encoder Wiring

3.3.1 Wiring Diagram

Incremental Encoder

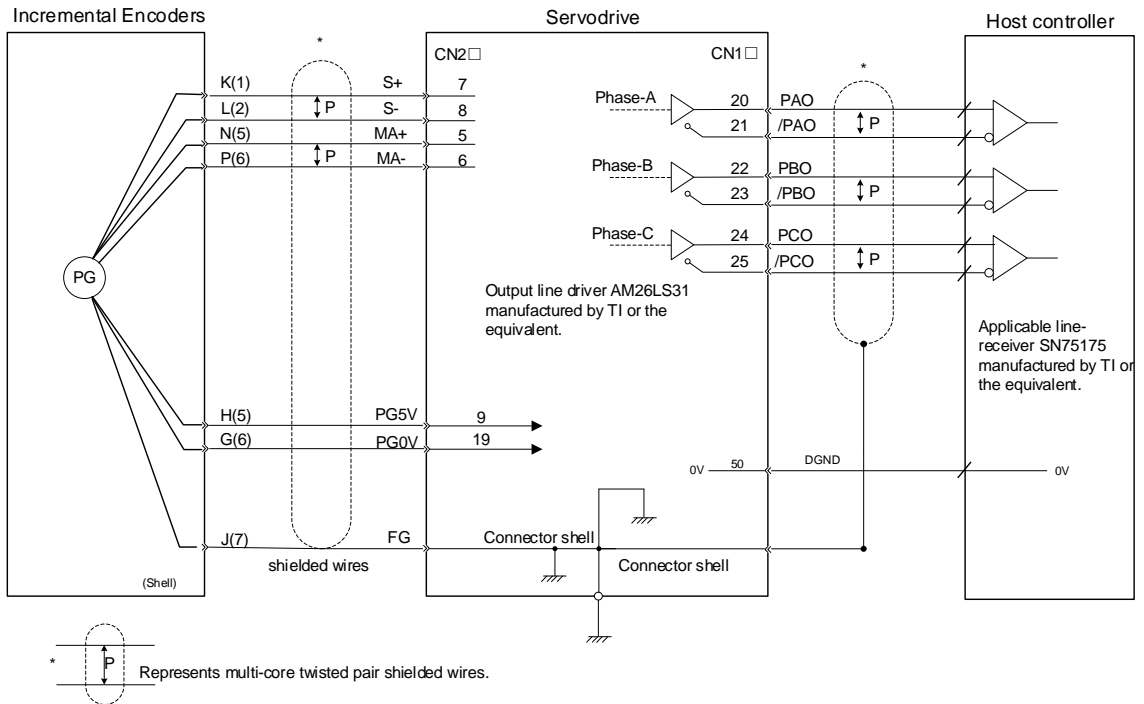

NOTE: The pin numbers for the connector wiring differ depending on the servomotors.

Absolute Encoder

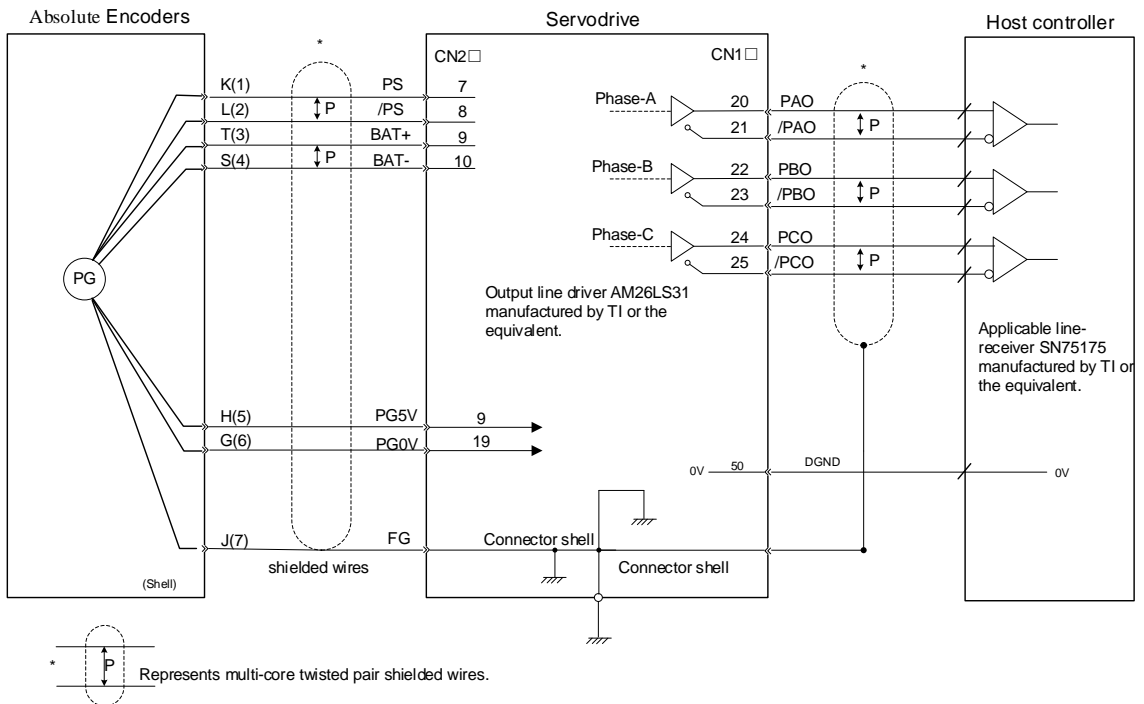

NOTE: The pin numbers for the connector wiring differ depending on the servomotors.

3.3.2 Terminal Layout

Incremental Encoder

Pin No.	Name	Description
1	PG5V	PG power supply (+5V)
2	PG0V	PG power supply (0V)
5	MA+	PG serial signal output
6	MA-	PG serial signal output
7	S+	PG serial signal input
8	S-	PG serial signal input

NOTE: Other pins are vacant.

Absolute Encoder

Pin No.	Name	Description
1	PG5V	PG power supply (+5V)
2	PG0V	PG power supply (0V)
7	PS	PG serial signal input
8	/PS	PG serial signal input
9	BAT+	Battery (+)
10	BAT-	Battery (-)

NOTE: Other pins are vacant.

3.4 Communication Wiring

Pin No.	Name	Description
1	–	Reserved
2	–	
3	485+	RS-485 communication terminal (+)
4	GND	Grounding
5	GND	
6	485-	RS-485 communication terminal (-)
7	CANH	CAN communication terminal (High level)
8	CANL	CAN communication terminal (Low level)

3.5 Wiring for Noise Control

3.5.1 Noise Control

The servodrive uses high-speed switching elements in the main circuit. It may receive "switching noise" from these high-speed switching elements.

To prevent malfunction due to noise, take the following actions:

- Position the input reference device and noise filter as close to the Servodrive as possible.
- Always install a surge absorber in the relay, solenoid and electromagnetic contactor coils.
- The distance between a power line (servomotor main circuit cable) and a signal line must be at least 30 cm. Do not put the power and signal lines in the same duct or bundle them together.
- Do not share the power supply with an electric welder or electrical discharge machine. When the servo drive is placed near a high-frequency generator, install a noise filter on the input side of the power supply line. As for the wiring of noise filter, see the section **Noise Filter**.
- For proper grounding technique, see the section **Correct Grounding**.

Noise Filter

Please install a noise filter in the appropriate place to protect the servo drive from external noise interference.

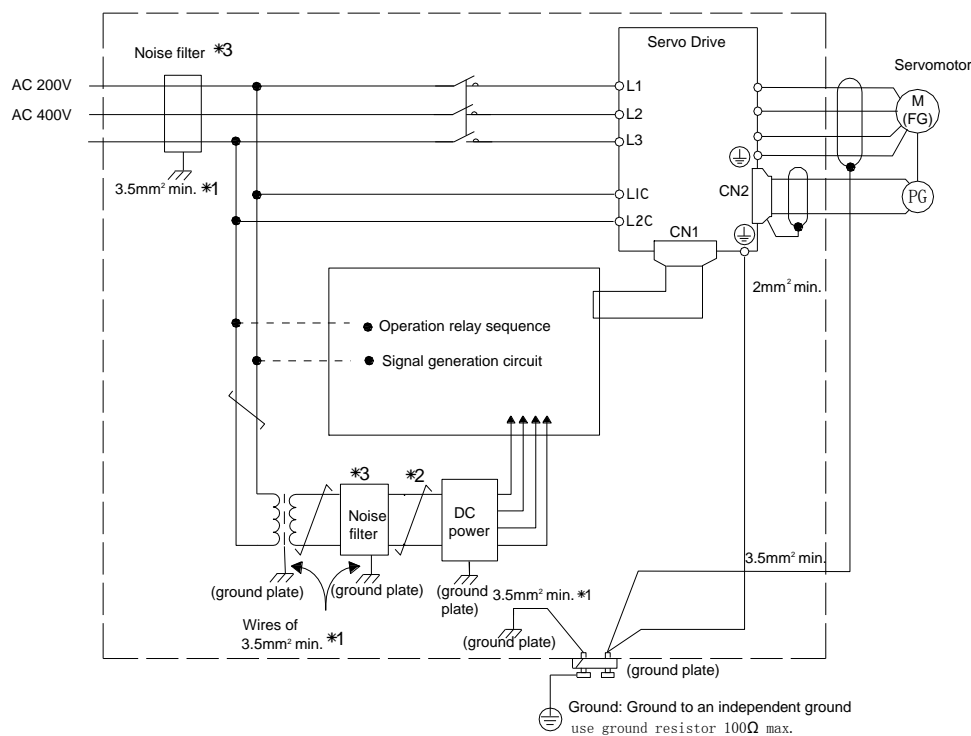

When using a noise filter, always observe the following wiring instructions:

- For a ground wire to be connected to the casing, use a thick wire with a thickness of at least 3.5 mm² (preferably, plain stitch cooper wire).
- For wires indicated by P↑, use twisted-pair cables whenever possible.

Correct Grounding

Take the following grounding measures to prevent the servo drive from malfunctioning due to noise.

- **Grounding the Motor Frame**

If the servomotor is grounded via the machine, a switching noise current will flow from the servo drive main circuit through the servomotor stray capacitance.

Always connect servomotor frame terminal FG to the servodrive ground terminal. Also be sure to ground the ground terminal ⊕

- **Noise on the I/O Signal Line**

If the I/O signal line receives noise, ground the 0 V line (SG) of the reference input line. If the main circuit wiring for the motor is accommodated in a metal conduit, ground the conduit and its junction box. For all grounding, ground at one point only.

Precautions on installing on the control panel

- When the servo drive is installed on the control panel, a piece of metal plate should be fixed. It is used for fixing the servo drive and other peripheral devices. The noise filter should be installed on the metal plate, and closed to the hole drill through power lines on control panel. Use screws to fix the noise filter to the metal plate. The grounding terminals of noise filter connects to the grounding terminals of control panel.
- Servo drive should be fixed on a piece of metal plate. Make sure the heat sink towards ground. The grounding terminals of servo drive connect to the grounding terminals of control panel.

3.5.2 Precautions on Connecting Noise Filter

Noise Filter Brake Power Supply

Use the noise filter Manufactured by SCHAFFNER at the brake power input for servomotors with holding brakes.

Relationship between servo drive power and noise filter current:

Servomotor Power	Noise Filter Current for single motor
50W	1.5A
100W	1.5A
200W	2A
400W	3A
750W	5A
1.0kW	6A



NOTE

- A single-phase servomotor should apply a two-phase filter. A three-phase servo drive should apply a three-phase filter.
- Choose the right filter according the specifications of operating voltage, current, and manufacturer.

Precautions on Using Noise Filters

- Do not put the input and output lines in the same duct or bundle them together.

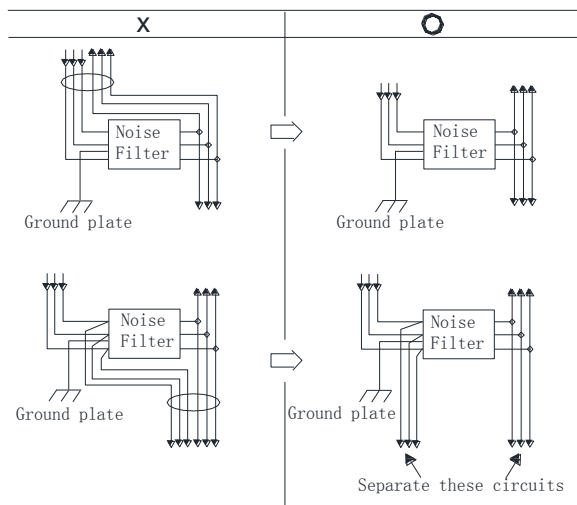

- Separate the noise filter ground wire from the output lines. Do not accommodate the noise filter ground wire, output lines and other signal lines in the same duct or bundle them together.

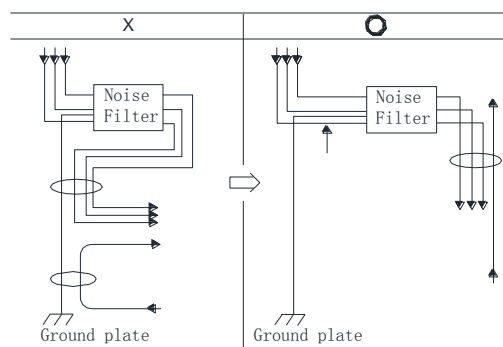

- Connect the noise filter ground wire directly to the ground plate. Do not connect the noise filter ground wire to other ground wires.

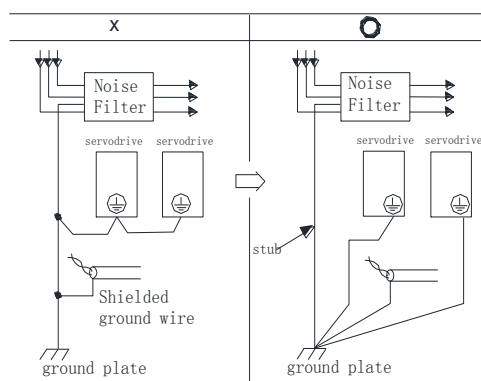

- If a noise filter is located inside a control panel, connect the noise filter ground wire and the ground wires from other devices inside the control panel to the ground plate for the control panel first, then ground these wires.

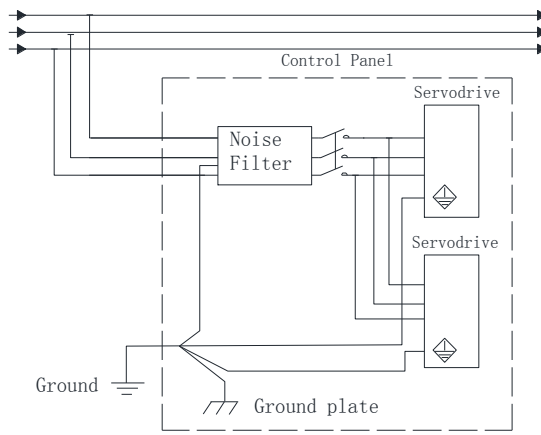

Chapter 4 Panel Operator

4.1 Basic Operation

4.1.1 Functions on Panel Operator

The panel operator is a built-in operator that consists of display section and keys located on the front panel of the servo drive.

Parameter setting, status display ,and execution of utility function are enabled using the panel operator.

The names and functions of the keys on the panel operator are shown as follows:

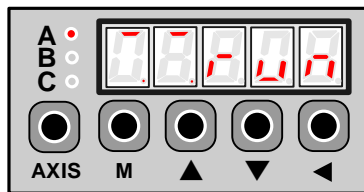

Symbol	Name	Description
AXIS	Axis key	Under the 1st-level menu, press the [AXIS] key to switch the control among axis-A, axis-B and axis-C.
▲	INC key	Press these keys to choose the desired parameters or set the value of the parameters.
▼	DEC key	
M	Mode key	Press [M] key to switch the mode among Status Display, Parameter Setting, Monitor and Utility Function. In addition, Press [M] key to save the setting of the parameter value and then back to the Parameter Setting mode.
◀	Enter key	Press [◀] key to display the parameters and values, and release the alarm.

4.1.2 Axis Switching

Since the Servodrive only can set and monitor only one axis at a time, the use can press the [AXIS] key to switch the control into another axis. The indicator lamp behind each axis can show the work status:

- Lit indicates the axis is controlled at present.
- Not lit indicates the axis is not controlled at present.
- Blinking indicates an alarm occurred in the axis not controlled at present.

4.1.3 Mode Switching

As is shown in the following figure, press [M] key can switch the mode among Status Display, Parameter Setting, Monitor and Utility Function in turns.

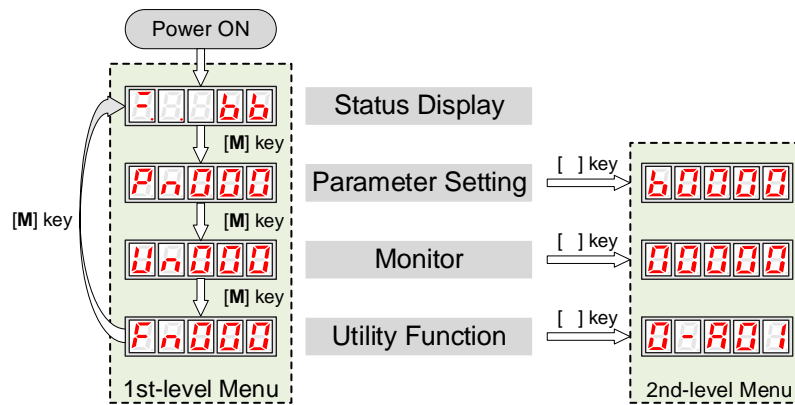

Note: Only under the 1st-level menu, press the [AXIS] key to switch the control among axis-A, axis-B and axis-C.

4.2 Status Display

The status display mode displays the servo drive status as bit data and codes.

The status display mode is selected when the power supply is turned ON. If it is not displayed, select this mode by pressing [M] key.

Note that the display differs between the speed/torque control and position control.

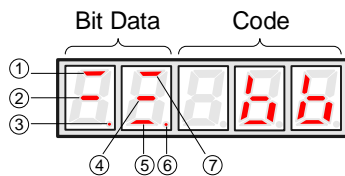





The following table lists the description of each bit data in speed/torque control and position control.

No.	Speed/Torque Control		Position Control	
	Bit Data	Description	Bit Data	Description
①	Speed Coincidence	Lit when the difference between the servomotor and reference speed is the same as or less than the preset value. Preset value:Pn501 (factory setting is 10 rpm) Always lit in torque control mode.	Positioning Completion	Lit if error between position reference and actual servomotor position is below preset value. Preset value: Pn500 (factory setting is 10 pulse).
②	Base lock	Lit for base block. Not lit at servo ON.	Base lock	Lit for base block. Not lit at servo ON.
③	Control power ON	Lit when servo drive control power is ON.	Control power ON	Lit when servo drive control power is ON.
④	—	Always not lit.	Reference pulse input	Lit if reference pulse is input. Not lit if no reference pulse is input.
⑤	Torque reference input	Lit if input torque reference exceeds preset value. Not lit if input torque reference is below preset value. Preset value: 10% of rated torque	Error counter clear signal input	Lit when error counter clear signal is input. Not lit when error counter clear signal is not input.

No.	Speed/Torque Control		Position Control	
	Bit Data	Description	Bit Data	Description
⑥	Power ready	Lit when main circuit power supply is ON and normal. Not lit when main circuit power supply is OFF.	Power ready	Lit when main circuit power supply is ON and normal. Not lit when main circuit power supply is OFF.
⑦	Rotation detection /TGON	Lit if servomotor speed exceeds preset value. Not lit if servomotor speed is below preset value. Preset value: Pn503 (factory setting is 20 rpm)	Rotation detection /TGON	Lit if servomotor speed exceeds preset value. Not lit if servomotor speed is below preset value. Preset value: Pn503 (factory setting is 20 rpm)

The following table lists the description of code.

Code	Description
	Base lock Servo OFF (motor power OFF)
	Run Servo ON (motor power ON)
	Forward Run Prohibited CN1□-10 (P-OT) is OFF
	Reverse Run Prohibited CN1□-10 (N-OT) is OFF
	Alarm Status Displays the alarm number

NOTE: Press [◀] key to try clearing the current alarms.

4.3 Operation in Parameter Setting Mode

The servo drive offers a large number of functions, which can be selected or adjusted by the parameter settings. For details about each parameters description see the section **Appendix A Parameters List**.

The following procedure is an example for changing the setting of parameter Pn102 from 100 to 85.

Step 1 Press [M] key for several times to switch into Parameter Setting mode, after turning the Servodrive ON.



Step 2 Press [▲] key or [▼] key to select the parameter Pn102.



Note: press and hold [▲] key or [▼] key to jump the parameter number quickly.

Step 3 Press [◀] key to display the current value of Pn102.

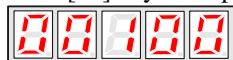

- Step 4** Press [▼] key or [▼] key to change the value to 00085.
Press and hold [▼] key or [▼] key to jump the setting value quickly.



- Step 5** Press [◀] key or [M] key to return to the display of the current parameter.



---End

4.4 Operation in Monitor Mode

The monitor mode allows the reference values input into the servo drive, I/O signal status, and servo drive internal status to be monitored.

Using the Monitor Mode

在 The example below shows how to display the value (1500) stored in Un001.

- Step 1** Press [M] key for several times to switch into Parameter Setting mode, after turning the Servodrive ON.



- Step 2** Press [▲] key or [▼] key to select the monitor number Un001.



- Step 3** Press [◀] key to display the current value of Un001.



- Step 4** Press [◀] key again to return to the display of the current monitor number.



---End

Descriptions of Monitor Number

Monitor Number	Description
Un000	Actual servomotor speed. Unit: rpm
Un001	Reserved
Un002	Reserved
Un003	Internal torque reference (relative to the rated torque). Unit: %
Un004	Number of encoder rotation angle pulses
Un005	Input signal monitor
Un006	Encoder signal monitor
Un007	Output signal monitor
Un008	Frequency given by pulse. Unit: 1kHz
Un009	Number of servomotor rotation pulses
Un010	Pulse rate of servomotor rotated (x10 ⁴)
Un011	Low 16-bit of the pulse deviation counter

Monitor Number	Description
Un012	High 16-bit of the pulse deviation counter
Un013	Number of pulses given
Un014	Number of pulses given (x10 ⁴)
Un015	Load inertia percentage
Un016	Servomotor overload ratio
Un017	Bus voltage .Unit: V

In which, the display meaning of Un005, Un006 and Un007 are shown as following table.

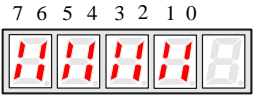
Displayed	Monitor Number	Meaning
	Un005	0: /SON 1: /P-CON 2: P-OT 3: N-OT 4: /ALM-RST 5: /CLR 6: /PCL 7: /NCL
	Un006	0: (Not used) 1: (Not used) 2: (Not used) 3: (Not used) 4: C 相 5: B 相 6: A 相 7: (Not used)
	Un007	0: ALM 1: /COIN 2: /TGON 3: /S-RDY

4.5 Operation in Utility Function Mode

In utility function mode, the panel operator can be used to run and adjust the servo drive and servomotor.

The following table lists the functions in the utility function mode.

Function Number	Description
Fn000	Alarm traceback data display
Fn001	Parameter setting initialization
Fn002	JOG mode operation
Fn003	Reserved
Fn004	Reserved
Fn005	Automatic adjustment of Servomotor current detection
Fn006	Manual adjustment of Servomotor current detection

Function Number	Description
Fn007	Software version display
Fn008	Position teaching
Fn009	Moment of Inertia Estimation
Fn010	Reserved
Fn011	Reserved
Fn012	Reserved for the Manufacturer
Fn013	Parameters copying
Fn014	Reserved

4.5.1 Alarm Traceback Data Display

The alarm traceback display can display up to 10 previously occurred alarms. The alarm is displayed on Fn000, which is stored in the alarm traceback data.

Follow the procedures below to confirm alarms which have been generated.

Step 1 Press [M] key for several times to switch into Utility Function mode, after turning the Servodrive ON.

Step 2 Press [▲] key or [▼] key to select the function number Fn000.



Step 3 Press [◀] key to display the latest alarm number.

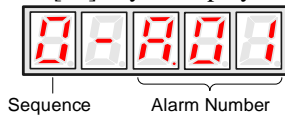

Step 4 Press [▲] key or [▼] key to display another alarm numbers occurred recently.

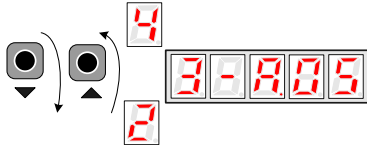

Step 5 Press [◀] key to return to the display of the current function number.

---End

4.5.2 Parameter Settings Initialization

Follow the procedures below to perform the parameter settings initialization.

Step 1 Press [M] key for several times to switch into Utility Function mode, after turning the Servodrive ON.

Step 2 Press [▲] key or [▼] key to select the function number Fn001.



Step 3 Press [◀] key to prepare for initializing the parameter settings.

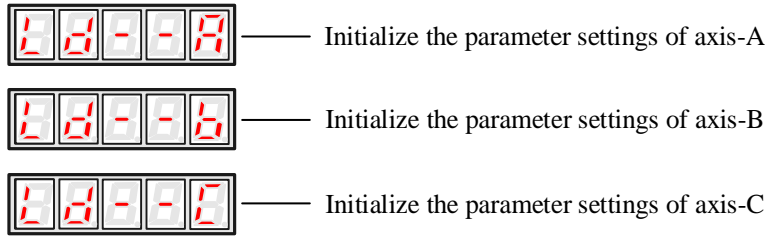

Step 4 Press and hold [◀] key for 1 second or more until “done” is displayed and blinked, which indicates the parameter settings initialization has been completed.

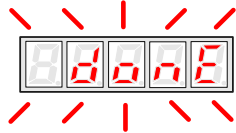

Step 5 Release [◀] key to return to the display of the current function number.



The parameter settings initialization can not be performed when servo is turned ON.
Turn OFF the servo before this operation.

---End

4.5.3 JOG Operation

Follow the procedures below to operate the Servomotor in JOG.

Step 1 Press [M] key for several times to switch into Utility Function mode, after turning the servo ON.

Step 2 Press [▲] key or [▼] key to select the function number Fn002.



Step 3 Press [◀] key to enter the JOG running mode.



Step 4 Press [M] key to turn ON the servo.

Here, you can press [M] key to turn ON or turn OFF the servo. However, Turn ON the servo if you want to run the Servomotor.

Step 5 Press [▲] key or [▼] key to run the Servomotor forward or reverse in a certain amount of movement.
Press and hold [▲] key or [▼] key to run the Servomotor continuously.

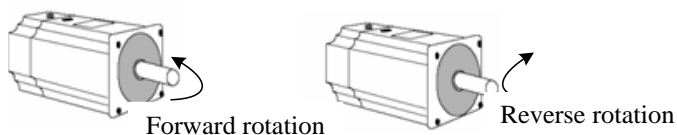

NOTE: the rotation direction of the Servomotor depends on the setting of Pn001.0. The above figure shows the default setting.

Step 6 Release [◀] key to return to the display of the current function number.
Moreover, the servo is turned OFF automatically.

---End

4.5.4 Offset Adjustment for Current Detection

Since the Offset Adjustment for Current Detection has been performed before the device leaves the factory, the user does not need to perform this operation generally.

However, Offset Adjustment for Current Detection shall be performed when the torque ripple was too large or if you want to further reduce the torque ripple.

This section describes the automatic and manual offset adjustment for current detection.



- Offset Adjustment for Current Detection is only can be performed at Servo OFF.
- If this function is inadvertently enabled, especially by manually adjustment, the characteristic deterioration will be occurred.
- It is necessary to perform the Offset Adjustment for Current Detection if the torque ripple is significantly too large.

Automatic Adjustment

Following the below procedure to perform the automatic adjustment.

Step 1 Press [M] key for several times to switch into Utility Function mode, after turning the servo ON.

Step 2 Press [▲] key or [▼] key to select the function number Fn005.



Step 3 Press [◀] key to prepare for performing the automatic adjustment.



Step 4 Press and hold [M] key for 1 second or more until “done” is displayed and blinked, which indicates the automatic adjustment has been completed.

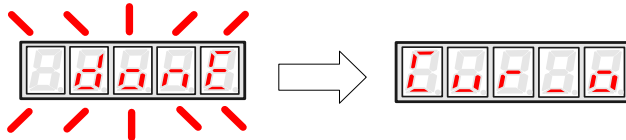

Step 5 Press [◀] key to return to the display of the current function number.

---End

Manual Adjustment

Following the below procedure to perform the manual adjustment.

Step 1 Press [M] key for several times to switch into Utility Function mode, after turning the servo ON.

Step 2 Press [▲] key or [▼] key to select the function number Fn006.

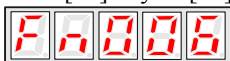

Step 3 Press [◀] key to prepare for performing the manual adjustment.

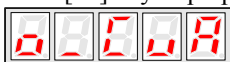

Step 4 Press [M] key to select the desired setting phase between phase-U (o_CuA) and phase-V (1_Cub).



Step 5 Press and hold [◀] key for 1 second, the detection value of current phase is displayed.



Step 6 Press [▲] key or [▼] key to change the value for the adjustment.

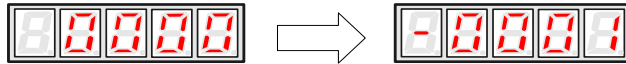

Step 7 Press and hold [◀] key for 1 second to return to the setting phase.

Step 8 Press [◀] key to return to the display of the current function number.



The adjusting range of the current detection offset is from -100 to +100.

---End

4.5.5 Software Version Display

Following the below procedure to perform the Software Version Display.

Step 1 Press [M] key for several times to switch into Utility Function mode, after turning the servo ON.

Step 2 Press [▲] key or [▼] key to select the function number Fn007.



Step 3 Press [◀] key to display the version of DSP software. (The leftmost bit is t).

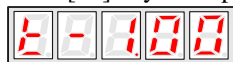

Step 4 Press [M] key to display the version of FPGA/CPLD software. (The leftmost bit is P).



Step 5 Press [M] key to return to the version of DSP software displayed.

Step 6 Press [◀] key to return to the display of the current function number.

---End

4.5.6 Position Teaching Function

Following the below procedure to perform the position teaching.

Step 1 Press [M] key for several times to switch into Utility Function mode, after turning the servo ON.

Step 2 Press [▲] key or [▼] key to select the function number Fn008.



Step 3 Press [◀] key to prepare for the position teaching.



Step 4 Press and hold [◀] key for 1 second or more until “done” is displayed and blinked, which indicates the position teaching has been completed.

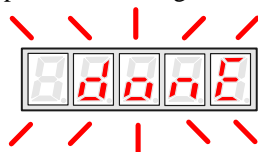

Step 5 Release [◀] key to return to the display of the current function number.

---End

4.5.7 Moment of Inertia Estimation

Following the below procedure to perform the Moment of Inertia Estimation.

Step 1 Press [M] key for several times to switch into Utility Function mode, after turning the servo ON.

Step 2 Press [▲] key or [▼] key to select the function number Fn009.



Step 3 Press [◀] key to prepare for the Moment of Inertia Estimation.



Step 4 Press [M] key for performing the operation.
The real-time rotational speed of the Servomotor is displayed.

Step 5 When the Servomotor is stopped, the estimation value is displayed on the panel operator, and its unit is kg.cm².



Make sure the Servomotor has completed at least 6 full revolutions in the CCW direction.

---End

4.5.8 Parameters Copying

Following the below procedure to perform the Parameters Copying.

Step 1 Press [M] key for several times to switch into Utility Function mode, after turning the servo ON.

Step 2 Press [▲] key or [▼] key to select the function number Fn013.



Step 3 Press [◀] key to prepare for the parameters copying.



PnA-b, meaning the parameter in axis-A will be copied to axis-B.



Pnb-A, meaning the parameter in axis-B will be copied to axis-A.

The meaning of the other displays are similar to the above.

Step 4 Press and hold [◀] key for 1 second or more until “done” is displayed and blinked, which indicates the parameter copying has been completed.

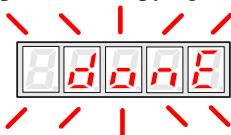

Step 5 Release [◀] key to return to the display of the current function number.

---End

Chapter 5 Operation without CANopen

5.1 Trial Operation

5.1.1 Flow of Trial Operation

Make sure that all the wiring has been completed before the trial operation.

Perform the following three methods of trial operation in order. Instructions are given for speed control mode (standard setting) and position control mode. Unless otherwise specified, the standard parameters for speed control mode (factory settings) are used.

Trial Operation for Servomotor Without Load

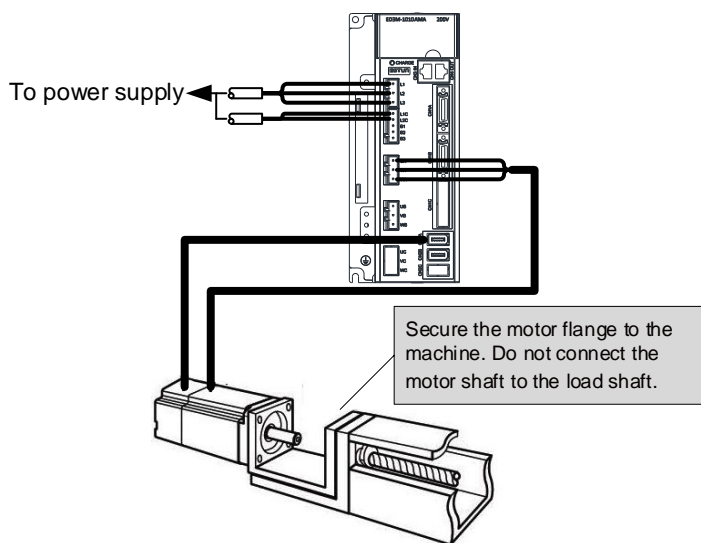

The servomotor is operated without connecting the shaft to the machine in order to confirm the following wiring is correct.

- Power supply circuit wiring
- Servomotor wiring
- Encoder wiring
- Rotation direction and speed of servomotor.

Trial operation for servomotor with host reference

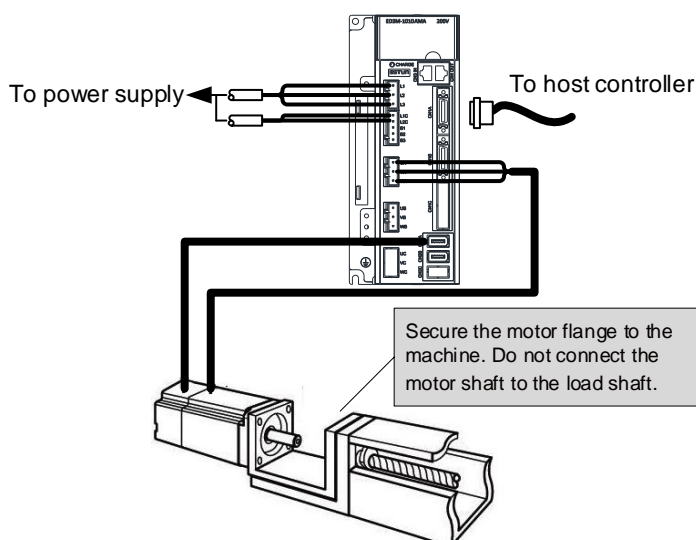

The servomotor is operated without connecting the shaft to the machine in order to confirm the following wiring is correct.

- I/O signal wiring with host controller
- Rotation direction, speed and number of rotations of servomotor
- Check the operation of the brake, overtravel and other protective functions

Trial operation for servomotor and machine combined

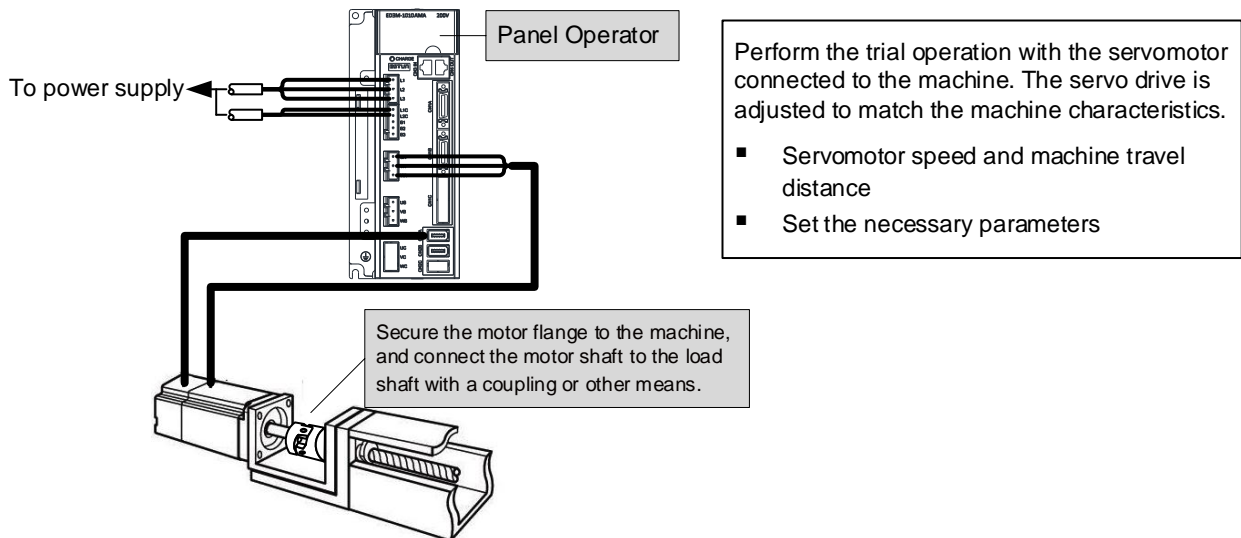

Procedure for the trial operation

Step 1 Installation

Install the servomotor and servo drive according to the installation conditions. (Do not connect the servomotor to the machine because the servomotor will be operated first under the no-load condition for checking.)

Step 2 Wiring

Connect the power supply circuit (L1, L2 and L3), servomotor wiring (U, V, W), I/O signal wiring (CN1 □), and encoder wiring (CN2 □). But during Trial Operation for Servomotor Without Load, disconnect the CN1 □ connector.

Step 3 Turn the power ON

Turn the power ON. Using the panel operator to make sure that the servo drive is running normally. If using a servomotor equipped with an absolute encoder, please perform the setup for the absolute encoder.

Step 4 Perform the JOG operation

Perform the JOG operation with the servomotor alone under the no-load condition.

Step 5 Connect input signals

Connect the input signals (CN1 □) necessary for trial operation to the Servodrive.

Step 6 Check input signals

Use the internal monitor function to check the input signals.
Turn the power ON, and check the emergency stop, brake, overtravel, and other protective functions for the correct operation.

Step 7 Input the Servo-ON signal

Input the Servo-ON signal, and turn ON the servomotor.

Step 8 Input reference

Input the reference necessary for control mode, and check the servomotor for correct operation.

Step 9 Protective operation

Turn the power OFF, and connect the servomotor to the machine.
If using a servomotor equipped with an absolute encoder, set up the absolute encoder and make the initial settings for the host controller to match the machine's zero position.

Step 10 Set necessary parameters

Using the same procedure as you did to input a reference in step 8, operate the servomotor via the host controller and set the parameter to make sure the machine's travel direction, travel distance, and travel speed all correspond to the reference.

Step 11 Run

The servomotor can now be operated. Adjust the servo gain if necessary.

---End

5.1.2 Trial Operation for Servomotor Without Load



Release the coupling between the servomotor and the machine, and secure only the servomotor without a load.

To prevent accidents, initially perform the trial operation for servomotor under no-load conditions (with all couplings and belts disconnected).

In this section, confirm the cable connections of the main circuit power supply, servomotor and encoder. Incorrect wiring is generally the reason why servomotors fail to operate properly during the trial operation.

Confirm the wiring, and then conduct the trial operation for servomotor without load according to the following steps.

Step 1 Secure the servomotor.

- Secure the servomotor flange to the machine in order to prevent the servomotor from moving during the operation.
- Do not connect the servomotor shaft to the machine. The servomotor may tip over during rotation.

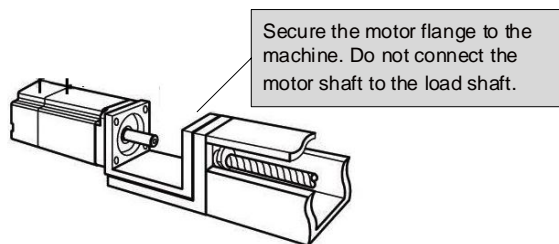
**Step 2** Check the power supply circuit, servomotor, and encoder wiring.

With the I/O signal connector (CN1 □) disconnected, check the power supply circuit and Servomotor wiring.

See the section 3.1 Main Circuit Wiring for the details about the wiring of the main circuit.

Step 3 Turn ON the control power supply and main circuit power supply.

If the power is correctly supplied, the panel operator display on the front panel of the Servodrive will appear as shown on the left. The display on the left indicates that forward run prohibited (P-OT) and reverse run prohibited (N-OT).

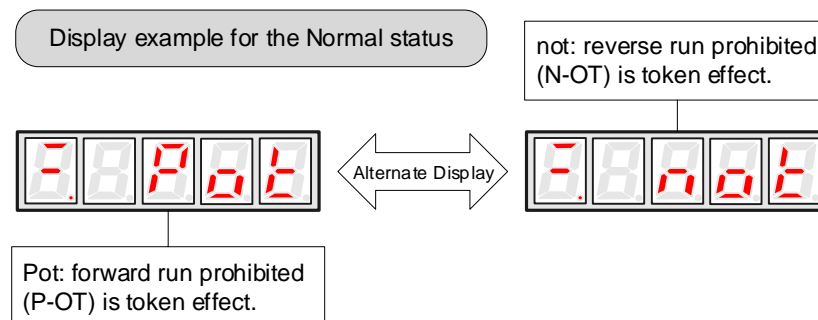

If an alarm display appears, the power supply circuit, servomotor wiring, or encoder wiring is incorrect. If an alarm is displayed, turn OFF the power, find the problem, and correct it.

Display example for the Alarm status

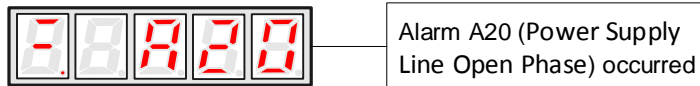

Step 4 When using a servomotor with a brake, release the brake first before driving the servomotor.

Step 5 Use the panel operator to operate the servomotor with utility function Fn002 (JOG Operation).

Check the Servomotor rotates in the forward direction by pressing [▲] key, and reverse direction by pressing [▼] key.

The operation is completed when the operation is performed as described below and no alarm occurs.

Complete the Fn002 (JOG Mode Operation) and turn OFF the power.

The servomotor speed can be changed using the Pn305 (JOG Speed). The factory setting for JOG speed is 500 rpm.

No.	Name	Range	Unit	Default	When Enabled	Related Control		
Pn305	JOG Speed	0 to 6000	rpm	500	Immediately	P	S	—

You can operate the panel operator instead of the host controller for Jog operation of the Servomotor.

Moreover, the signal of P-OT and N-OT are invalid during the Jog operation.

---End

5.1.3 Trial Operation for Servomotor without Load from Host Controller

Check that the servomotor move reference or I/O signals are correctly set from the host controller to the servo drive.

Also check the wiring and polarity between the host controller and servo drive, and the servo drive operation settings are correct. This is the final check before connecting the servomotor to the machine.

Operating Procedure in Position Control Mode (Pn005=H—1—)

The following circuits are required: External input signal circuit or equivalent.

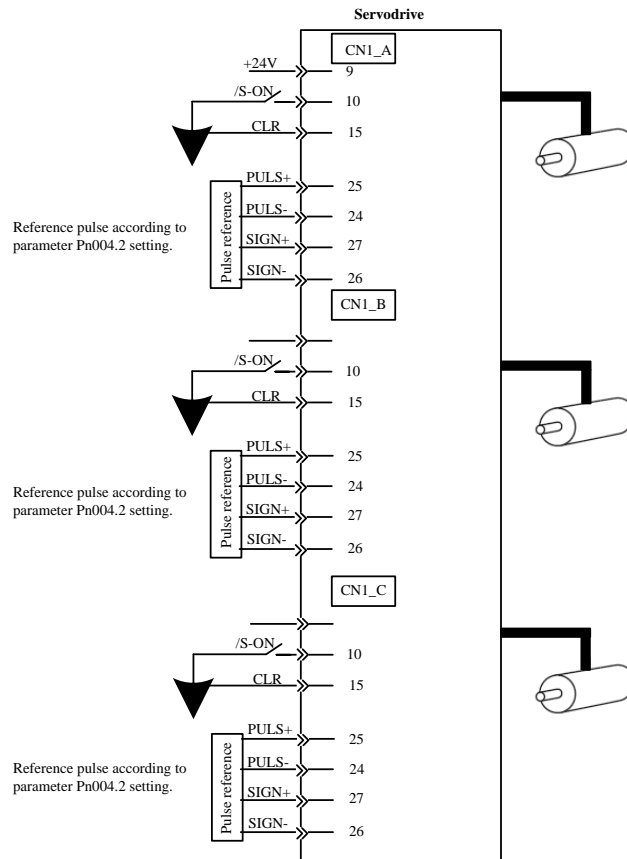

- Step 1** Match the reference pulse form with the pulse output form from the host controller.
Set the reference pulse form with Pn004.2.
- Step 2** Set the reference unit and electronic gear ratio so that it coincides with the host controller setting.
Set the electronic gear ratio with Pn201 (or Pn203)/Pn202.
- Step 3** Turn the power and the servo ON input signal ON.
- Step 4** Send the slow speed pulse reference for the number of servomotor rotation easy to check (for example, one servomotor revolution) from the host controller in advance.
Set the servomotor speed to 100rpm for the reference pulse speed because such speed is safe.
- Step 5** Check the number of reference pulses input to the servo drive by the changed amount before and after the Un013 and Un014 (input reference pulse counter)[pulse] were executed.
See the section 4.4 Operation in Monitor for the details about how it is displayed.
- Step 6** Check whether the actual number of servomotor rotations Un009, Un010 coincides with the number of input reference pulses.
See the section 4.4 Operation in Monitor for the details about how it is displayed.
- Step 7** Check that the servomotor rotation direction is the same as the reference.
Check the input pulse polarity and input reference pulse form.
- Step 8** Input the pulse reference with the large number of servomotor rotation from the host controller to obtain the constant speed.
Set the servomotor speed to 100rpm for the reference pulse speed because such speed is safe.
- Step 9** Check the reference pulse speed input to the servo drive using the Un008 in Monitor Mode.(input reference pulse speed)[rpm].
See the section 4.4 Operation in Monitor for the details about how it is displayed.
- Step 10** Check the servomotor speed using the Un000 in Monitor Mode. (servomotor speed) [rpm].
See the section 4.4 Operation in Monitor for the details about how it is displayed.
- Step 11** Check the rotation of the Servomotor.
To change the servomotor rotation direction without changing the input reference pulse form, see the

section 5.3.2 Rotation Direction.

Perform the operation from step 8 again after the servomotor rotation direction is changed.

- Step 12** When the pulse reference input is stopped and servo OFF status is entered, the trial operation for servomotor without load in position control mode is complete.

---End

5.1.4 Trial Operation with the Servomotor Connected to the Machine



Follow the procedure below for trial operation precisely as given.

Malfunctions that occur after the servomotor is connected to the machine not only damage the machine, but may also cause an accident resulting in death or injury.

Follow the procedure below to perform the trial operation.

- Step 1** Turn the power ON, and make the settings for the mechanical configuration related to protective functions such as overtravel and brake.
See the section 5.3 Basic Functions Setting.
When a servomotor with brake is used, take advance measures to prevent vibration due to gravity acting on the machine or external forces before checking the brake operation. Check that both servomotor and brake operations are correct.
- Step 2** Set the necessary parameters for the control mode used.
Refer to the sections 5.5 Speed Control and 5.6 Position Control according to the control method.
- Step 3** Connect the servomotor to the machine with the coupling, etc., while the power is OFF.
- Step 4** Check that the servo drive is servo OFF status and then turn ON the power to the machine (host controller). Check again that the protective function in step 1 operates normally.
See the section 5.3 Basic Functions Setting.
For the following steps, take advanced measures for an emergency stop so that the servomotor can stop safely when an error occurs during operation.
- Step 5** Perform trial operation with the servomotor connected to the machine, following each section in 5.1.2 Trial Operation for Servomotor Without Load.
Check that the trial operation is completed according to the trial operation for servomotor without load. Also, check the settings for machine such as reference unit.
- Step 6** Check the parameter settings for control mode used in step 2.
Check that the servomotor rotates matching the machine operating specifications.
- Step 7** Adjust the servo gain and improve the servomotor response characteristics, if necessary.
The servomotor will not be broken in completely during trial operation. Therefore, let the system run for a sufficient amount of time to ensure that it is properly broken in.

---End

5.1.5 Trial Operation for Servomotor with Brakes

Holding brake operation of the servomotor can be controlled with the brake interlock output (/BK) signal of the servo drive.

When checking the brake operation, take advance measures to prevent vibration due to gravity acting on the machine or external forces. Check the servomotor operation and holding brake operation with the servomotor separated from the machine. If both operations are correct, connect the servomotor to the machine and perform trial operation.

5.2 Control Method Setting

The control modes supported by the ED3M series Servodrives are described below.

Parameter No.	Setting	Description
Pn005	H - - 0 -	Speed control (parameter reference) Controls servomotor speed using parameter reference. Use in the following instances. <ul style="list-style-type: none"> To control speed For position control using the encoder feedback division output from the servo drive to form a position loop in the host controller.
	H - - 1 -	Position Control (Pulse train reference) Controls the position of the servomotor using pulse train position reference. Controls the position with the number of input pulses, and controls the speed with the input pulse frequency. Use this method when positioning is required.
	H - - 2 -	Speed control (contact reference) ↔ Speed control (Zero reference) Use the three input signals /P-CON, /P-CL and /N-CL to control the speed as set in advance in the servo drive. Three operating speeds can be set in the servo drive. (In this case, an analog reference is not necessary.)
	H - - 3 - H - - 4 - H - - 5 -	These are switching modes for using the four control methods described above in combination. Select the control method switching mode that best suits the application.

5.3 Basic Functions Setting

5.3.1 Servo ON

This sets the servo ON signal (/S-ON) that determines whether the Servomotor power is ON or OFF.

/S-ON Signal

Type	Name	Connector Pin	Setting	Meaning
Input	/S-ON	CN1□-10 CN1□-15 [Default]	ON (Low level)	Power ON the Servomotor.
			OFF (high level)	Power OFF the Servomotor.



IMPORTANT

- Always input the servo ON signal before inputting the input reference to start or stop the servomotor.
Do not input the input reference first and then use the /S-ON signal to start or stop. Doing so will degrade internal elements and may cause the servo drive to malfunction.
- A parameter can be used to re-allocate the input connector number for the /S-ON signal, refers to the section **3.2.3 Names and Functions**.

/S-ON Selection

A parameter can be always used to set the servo ON condition. This eliminates the need to wire /S-ON, but care must be taken because the servo drive can operate as soon as the power is turned ON.

Parameter No.	Setting	Meaning
Pn000	b - - - 0	External S-ON signal enabled (Factory setting)
	b - - - 1	External S-ON signal disabled, the servomotor excitation signal is opened automatically after outputting the S-RDY signal.









NOTE: After changing these parameters, turn OFF the main circuit and control power supplies, and then turn them ON again to enable the new settings.

5.3.2 Rotation Direction

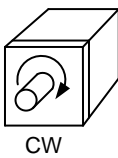
The rotation direction of the servomotor can be switched without changing the reference pulse to the servo drive or the reference voltage polarity.

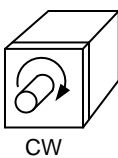
This causes the rotation the servo motor shaft is rotating to change. The output signal polarity, such as the encoder pulse output and the analog monitor signal from the servo drive do not change.

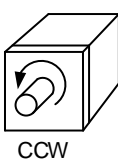
The standard setting for “forward rotation” is counterclockwise as viewed from the servomotor load end.

Parameter No.	Setting	Name	Reference	Feedback
Pn001	b - - - 0	Use CCW as the forward direction.	Forward	 Pulse output from the encoder PAO  PBO  Phase-B ahead CCW
			Reverse	 Pulse output from the encoder PAO  Phase-A ahead PBO  CW
	b - - - 1	Use CW as the forward direction.	Forward	 Pulse output from the encoder PAO  PBO  Phase-B ahead CW
			Reverse	 Pulse output from the encoder PAO  Phase-A ahead PBO  CCW

NOTE: The direction of P-OT and N-OT change. For Pn001=b - - - 0 (standard setting), counterclockwise is P-OT. For Pn001=b - - - 1 (reverse rotation mode), clockwise is P-OT.

5.3.3 Overtravel

The overtravel limit function forces movable machine parts to stop if they exceed the allowable range of motion and turn ON a limit switch.

Overtravel Connection

To use the overtravel function, connect the following overtravel limit switch to the corresponding pin number of servo drive CN1□ connector correctly.

Type	Name	Pin No.	Setting	Meaning
Input	P-OT	Allocate them by Pn509	ON (low level)	Forward rotation allowed. (Normal operation status.)
			OFF (high level)	Forward rotation prohibited. (Forward overtravel)
Input	N-OT		ON (low level)	Reverse rotation (Normal operation status.)
			OFF (high level)	Reverse rotation prohibited. (Reverse overtravel)

Connect limit switches as shown below to prevent damage to the devices during linear motion.

Rotation in the opposite direction is possible during overtravel.

For example, reverse rotation is possible during forward overtravel.

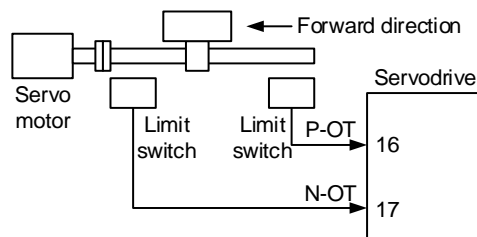

IMPORTANT

- When using overtravel to stop the servomotor during position control, the position error pulses are present. A clear signal (CLR) input is required to clear the error pulses.
- When using the servomotor on a vertical axis, the workpiece may fall in the overtravel condition.
- To prevent this, always set the zero clamp after stopping with Pn004.0=5.

Overtravel Selection

A parameter can be set to disable the overtravel signal. If the parameter is set, there is no need to wire the overtravel input signal.

Parameter No.	Setting	Meaning
Pn000	b - - 0 -	Inputs the forward rotation prohibited (P-OT) signal from CN1□-12.
	b - - 1 -	Disables the forward rotation prohibited (P-OT) signal.
	b - 0 - -	Inputs the reverse rotation prohibited (P-OT) signal from CN1□-13.
	b - 1 - -	Disables the reverse rotation prohibited (P-OT) signal.

NOTE: After changing these parameters, turn OFF the main circuit and control power supplies, and then turn them ON again to enable the new settings.

Stop Method

This is used to set the stop method when an overtravel(P-OT,N-OT)signal is input while the servomotor is operating.

Parameter No.	Setting	Stop Method	After Motor Stop	Description
Pn004	H - - - 0	Stop by dynamic brake	Coast	Rapidly stops the servomotor by dynamic braking (DB), then places it into coast (power OFF) mode.
	H - - - 1	Coast to a stop		Stops the servomotor in the same way as when the servo is OFF (coast to a stop), then places it into coast (power OFF) mode.
	H - - - 2	S-OFF or Overtravel	Coast	Stops the servomotor by dynamic braking (DB) when servo OFF, stops the servomotor by plug braking when overtravel, and then places it into coast (power OFF) mode.
	H - - - 3			Makes the servomotor coast to a stop state when servo OFF, stops the servomotor by plug braking when overtravel, and then places it into coast (power OFF) mode.
	H - - - 4		Zero Clamp	Stops the servomotor by dynamic braking (DB) when servo OFF, stops the servomotor by plug braking when overtravel, and then places it into zero clamp mode.
	H - - - 5			Makes the servomotor coast to a stop state when servo OFF, stops the servomotor by plug braking when overtravel, then places it into zero clamp mode.

NOTE: After changing these parameters, turn OFF the main circuit and control power supplies, and then turn them ON again to enable the new settings.



NOTE

- Stop by dynamic brake: Stops by using the dynamic brake (short circuiting its electrical circuit).
- Coast to a stop: Stops naturally, with no brake, by using the friction resistance of the servomotor in operation.
- Plug braking: Stops by using plug braking limit torque.
- Zero Clamp Mode: A mode forms a position loop by using the position reference zero.

Dynamic brake is an emergency stop function, and one of the general methods to cause a servomotor sudden stop.

Dynamic brake suddenly stops a servomotor by shorting its electrical circuit.

If the servomotor is frequently started and stopped by turning the power ON/OFF or using the servo ON signal(/S-ON), the DB circuit will also be repeatedly operated, degrading the servo drive's internal elements.

Use the speed input reference and position reference to control the starting and the stopping of the servomotor.

Stop Torque for Overtravel

Parameter No.	Name	Range	Unit	Default	When Enabled	Related Control		
Pn405	Plug braking torque limit	0 to 300	%	300	Immediately	P	S	-



- This sets the stop torque for when the overtravel signal(P-OT,N-OT) is input.
- The setting unit is a percentage of the rated torque.(the rated torque is 100%)
- The value large enough to be the servomotor maximum torque, 300% is set as the factory setting for plug braking limit torque.However, the actual output plug braking limit torque is determined by servomotor ratings.

5.3.4 Holding Brakes Setting

The holding brake is used when the servo drive controls a vertical axis.

A servomotor with the brake option helps prevent movable parts from shifting due to gravity when power is removed from the servo drive.(Refer to the section 5.1.5 Trial Operation for Servomotor with Brakes.)

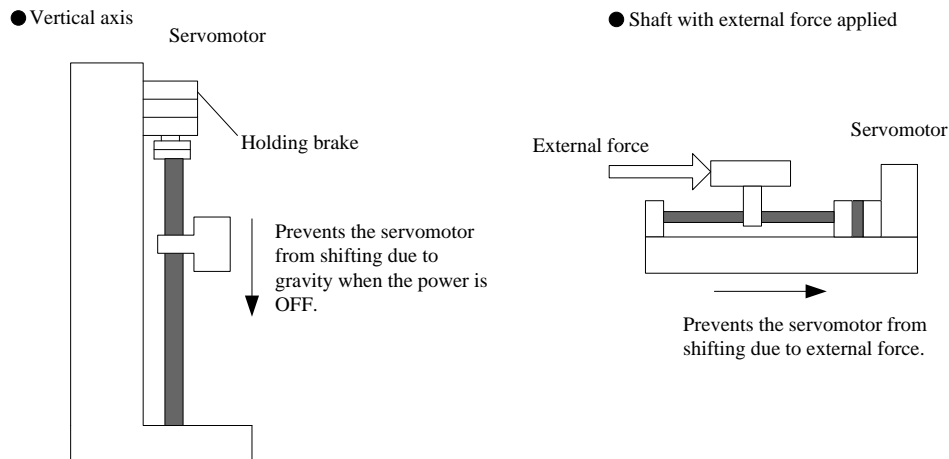

IMPORTANT

- The servomotor with the built in brake, is a de-energization brake. It is used to hold the servomotor and cannot be used as a braking purposes. Use the holding brake only to hold a stopped servomotor.
- When operating using only a speed loop, turn OFF the servo and set the input reference to 0V when the brake is applied.
- When forming a position loop, do not use a mechanical brake while the servomotor is stopped because the servomotor enters servolock status.

Wiring Example

Use the servo drive sequence output signal /BK and the brake power supply to form a brake ON/OFF circuit. The following diagram shows a standard wiring example.

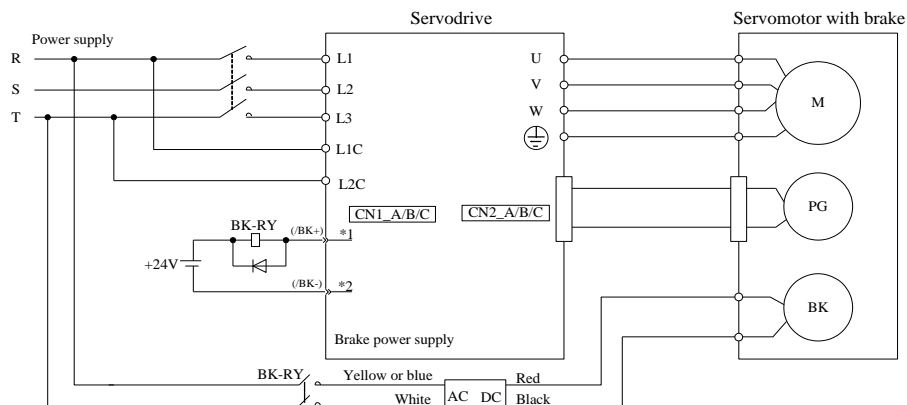

BK-RY: Brake control relay

1*, 2*: The output terminals allocated with Pn511.

Brake interlock output

Type	Name	Pin No.	Setting	Meaning
Output	/BK	Must be allocated	ON (low level)	Releases the brake.
			OFF (high level)	Applies the brake.

NOTE: This output signal controls the brake and is used only for a servomotor with a brake. This output signal is not used with the factory setting. The output signal must be allocated by Pn511. It does not need to be connected for servomotor without a brake.

/BK Allocation

Brake interlock output (/BK) is not used with the factory setting. The output signal must be allocated.

Parameter No.	Setting	Pin No.		Meaning
		+ Terminal	- Terminal	
Pn511	H - - - 4	CN1□-11	CN1□-12	The /BK signal is output from output terminal CN1□-11, -12.
	H - - 4 -	CN1□-5	CN1□-6	The /BK signal is output from output terminal CN1□-5, -6.
	H - 4 - -	CN1□-9	CN1□-10	The /BK signal is output from output terminal CN1□-9, -10.



IMPORTANT

- The setting of /BK signal is invalid in default setting.
- For the allocation of servo drive output signals other than /BK signal, refer to the section **3.2.3 Names and Functions**.

Parameter Pn511 description is as following:

Pin No.	Description
0	/COIN (/V-CMP) output
1	/TGON rotation detecting output
2	/S-RDY servo drive get ready output
3	/CLT torque limit output
4	/BK brake interlock output
5	/PGC encoder C pulse output
6	OT overtravel signal output
7	/RD servo enabled motor excitation output
8	/HOME home completion output
9	/TCR torque detection output

Relevant parameters are as following:

Parameter No.	Name	Unit	Range	Default
Pn505	Servo ON waiting time	ms	-2000 to 2000	0
Pn506	Basic waiting flow	10ms	0 to 500	0
Pn507	Brake waiting speed	rpm	10 to 100	100
Pn508	Brake waiting time	10ms	10 to 100	50

Brake ON/OFF Setting for Servomotor Stop

The /BK signal is output at the same time as the servo is turned OFF in the default setting. The servo OFF timing can be changed with a parameter.

Parameter No.	Name	Range	Unit	Default	When Enabled	Related Control		
						P	S	-
Pn505	Servo ON waiting time	-2000 to 2000	ms	0	Immediately	P	S	-
Pn506	Basic waiting flow	0 to 500	10ms	0	Immediately	P	S	

When using the servomotor to control a vertical axis, the machine movable parts may shift slightly depending on the brake ON/ OFF timing due to gravity or an external force. By using this parameter to delay turning the servo ON/ OFF, this slight shift can be eliminated.

For details on brake operation while the servomotor is operating, refer to **Brake ON/OFF Setting for Servomotor Running**.

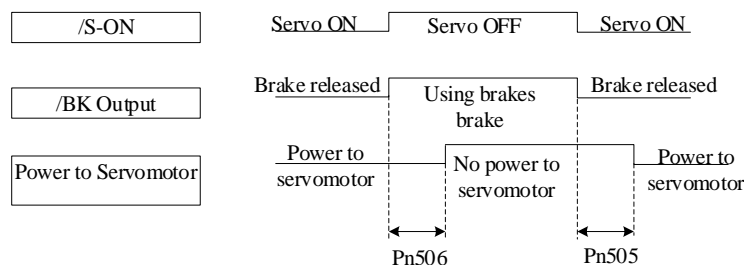

IMPORTANT

- The servomotor will turn OFF immediately when an alarm occurs, regardless of the setting of this parameter.
- The machine movable part may shift due to gravity or external force during the time until the brake operates.

Brake ON/OFF Setting for Servomotor Running

The following parameters can be used to change the /BK signal output conditions when a stop reference is output during servomotor operation due to the servo OFF or an alarm occurring.

Parameter No.	Name	Range	Unit	Default	When Enabled	Related Control		
						P	S	-
Pn507	Brake Waiting Speed	10 to 100	1rpm	100	Immediately	P	S	-
Pn508	Brake Waiting Time	10 to 100	10ms	50	Immediately	P	S	-

The /BK signal goes to high level(brake ON) when either of the following conditions is satisfied:

- When the servomotor speed falls below the level set in Pn507 after servo OFF.
- When the time set in Pn508 is exceeded after servo OFF.

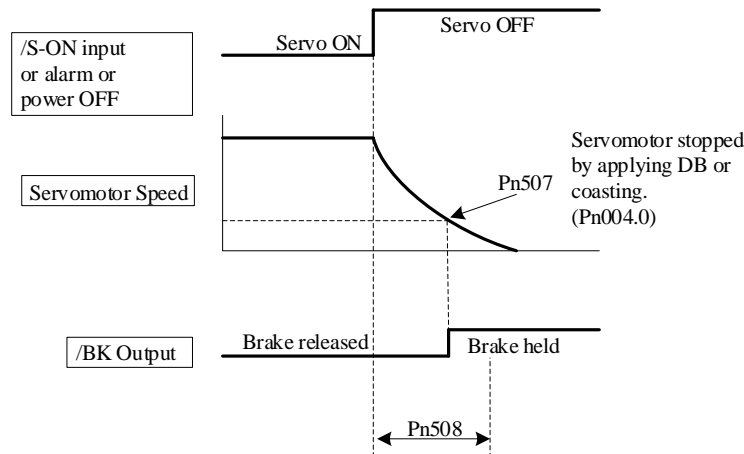

5.4 Absolute Encoders

Type	Resolution	Data Range	Action for over-limit
ED3M model	16-bit, multiturn 17-bit, singleturn	-32768 to +32767	<ul style="list-style-type: none"> • When the upper limit (+32767) is exceeded in the forward direction, the multiturn data is -32768 • When the lower limit (-32768) is exceeded in the reverse direction, the multiturn data is +32767.

The absolute position can be read by the MODBUS protocol. In the actual control, the MODBUS protocol can read the initial position when the servomotor is stopped (S-OFF), then the real-time position during the servomotor is running can be found from the number of PG divided output pulses.

5.4.1 Absolute Encoder Selection

An absolute encoder can also be used as an incremental encoder.

Parameter No.	Setting	Meaning
Pn002	b - 0 - -	Use the absolute encoder as an absolute encoder. (Factory setting)
	b - 1 - -	Use the absolute encoder as an incremental encoder.

NOTE: The back-up battery is not required when using the absolute encoder as an incremental encoder. After changing these parameters, turn OFF the main circuit and control power supplies and then turn them ON again to enable the new settings.

5.4.2 Handling Battery

In order for the absolute encoder to retain position data when the power is turned OFF, the data must be backed up by a battery.

Please purchase the special cable and battery case made by Estun if an absolute encoder is used.

Install the battery to the encoder cable:

Step 1 Open the shell of the battery case.

Step 2 Install the battery according to the following diagram.

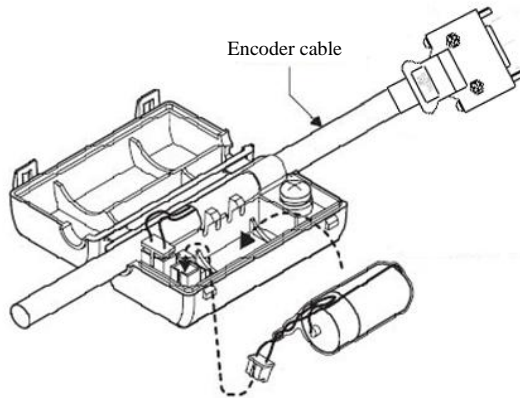

Step 3 Cover the shell of the battery case.

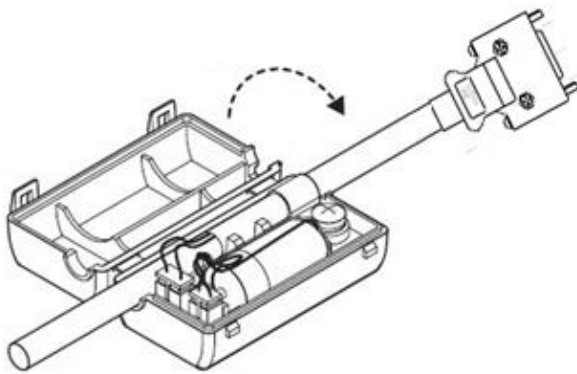

---End

5.4.3 Replacing Battery

The servo drive will generate an absolute encoder battery alarm (A.48) when the battery voltage drops below about 3.1V.

Battery Replacement Procedure is as following.

Step 1 Replace the battery with only the servo drive control power supply turned ON.

Step 2 After replacing the battery, using the panel operator with utility function Fn011 to cancel the absolute encoder battery alarm (A.48).

Step 3 Turn ON the servo drive power back again. If it operates without any problems, the battery replacement has been completed.



IMPORTANT

- The servo drive will generate an absolute encoder battery alarm (A.48) when the battery voltage drops below about 3.1V.
- If an absolute encoder battery alarm (A.47) occurred, it means the battery voltage drops below about 2.5V, and the multiturn data is lost. Please reset the absolute encoder after changing the battery.

---End

5.4.4 Absolute Encoder Setup (Fn010, Fn011)

Setting up the absolute encoder in the following cases.

- When starting the machine for the first time, set Pn002.2 to 0.
- When an encoder error alarm (A.45 to A.48, A.51) is generated. Use the panel operator in the servo drive for setup.



- Encoder setup operation is only possible when the servo is OFF.
- If the absolute encoder alarms(A.45 to A.48, A.51) are displayed, cancel the alarm by using the same method as the setup. They cannot be cancelled with the servo drive alarm reset input signal(/ALM-RST).
- Any other alarms that monitor the inside of the encoder should be cancelled by turning OFF the power.

5.5 Speed Control

5.5.1 Parameter Setting

Parameter No.	Setting	Meaning
Pn005	H - - 0 -	Control mode selection:Speed control (Internally set speed) [factory setting]

5.5.2 Soft Start

The soft start function converts the stepwise speed reference inside the servo drive to a consistent rate of acceleration and deceleration.

Pn310 can be used to select the soft start form:

: Slope; 1: S curve; 2: 1st-order filter; 3: 2nd-order filter

Parameter No.	Name	Range	Unit	Default	When Enabled	Related Control		
Pn306	Soft Start Acceleration Time	0 to 10000	1ms	0	Immediately	-	S	-
Pn307	Soft Start Deceleration Time	0 to 10000	1ms	0	Immediately	-	S	

The soft start function enables smooth speed control when inputting a stepwise speed reference or when selecting internally set speeds. Set both Pn306 and Pn307 to "0" for normal speed control.

Set these parameters as follows:

- Pn306: The time interval from the time the servomotor starts until the servomotor is 1000rpm.
- Pn307: The time interval from the time the servomotor is 1000rpm until it stops.

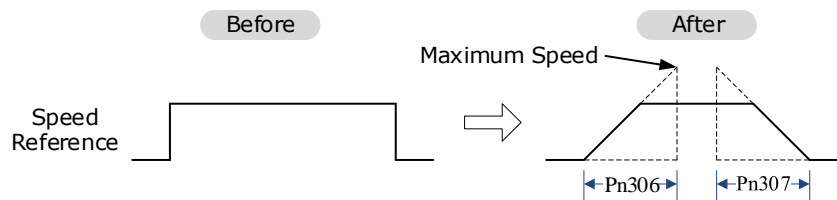

5.5.3 Speed Reference Filter Time Constant

Parameter No.	Name	Range	Unit	Default	When Enabled	Related Control		
Pn308	Speed Reference Filter Time Constant	0 to 10000	1ms	0	Immediately	-	S	-

NOTE: This smooths the speed reference by applying a 1st-order delay filter to the analog speed reference (V-REF) input. A value that is too large, however, will decrease response.

5.5.4 S-curve Risetime

Parameter No.	Name	Range	Unit	Default	When Enabled	Related Control		
Pn309	S-curve Rise time	0 to 10000	1ms	0	Immediately	-	S	-

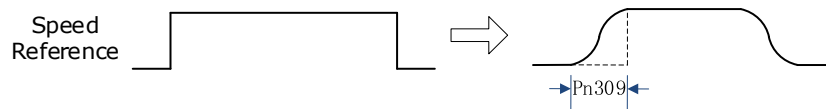

5.5.5 Speed coincidence output

The speed coincidence (/V-CMP) output signal is output when the actual servomotor speed during speed control is the same as the speed reference input. The host controller uses the signal as an interlock.

Type	Signal Name	Pin No.	Setting	Meaning
Output	/V-CMP (/COIN)	CN1□-7,8 [Default setting]	ON (low level)	Speed coincides.
			OFF (high level)	Speed does not coincide.

Parameter No.	Name	Range	Unit	Default	When Enabled	Related Control		
Pn501	Coincidence Difference	0 to 100	rpm	10	Immediately	-	S	-

The /V-CMP signal is output when the difference between the speed reference and actual servomotor speed is less than Pn501.

For example, the /V-CMP signal turns ON at 1900 to 2100rpm if the Pn501 parameter is set to 100 and the reference speed is 2000rpm

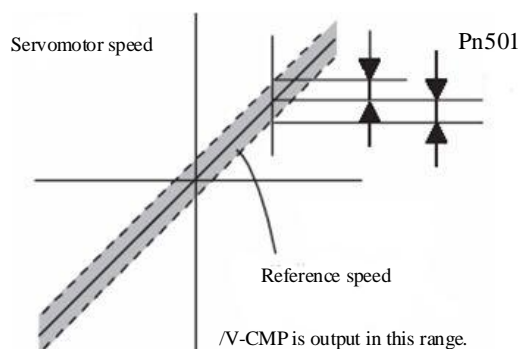

**NOTE**

This pin outputs the /COIN signal in position control mode, and the /V-CMP signal in speed control mode.

5.5.6 Speed control (contact reference)

The function of internally set speed selection allows speed control operation by externally selecting an input signal from among seven servomotor speed setting made in advance with parameters in the servo drive. The speed control operations within the three settings are valid. There is no need for an external speed or pulse generator.

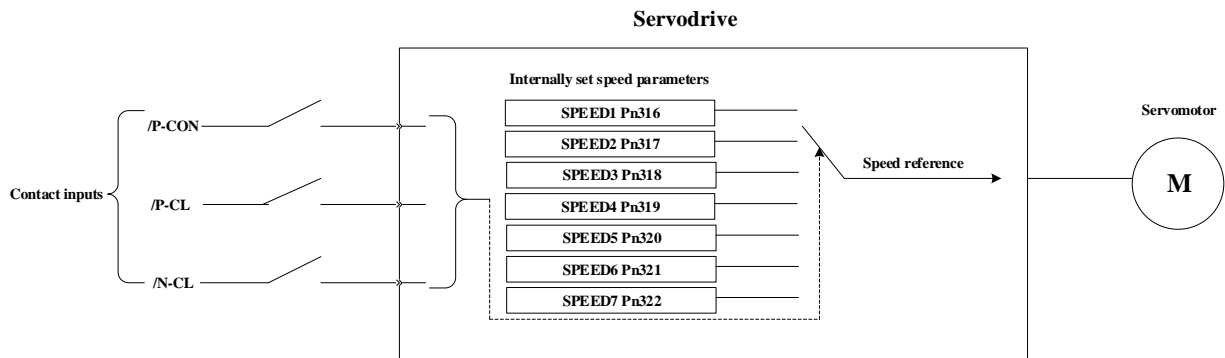

Parameter setting

Parameter No.	Setting	Meaning
Pn005	H - - 2 -	Speed control (contact reference)

Parameter No.	Name	Range	Unit	Default	When Enabled	Related Control		
						-	S	-
Pn316	Internal set speed 1	-6000 to 6000	rpm	100	Immediately	-	S	-
Pn317	Internal set speed 2	-6000 to 6000	rpm	200	Immediately	-	S	-
Pn318	Internal set speed 3	-6000 to 6000	rpm	300	Immediately	-	S	-
Pn319	Internal set speed 4	-6000 to 6000	rpm	-100	Immediately	-	S	-
Pn320	Internal set speed 5	-6000 to 6000	rpm	-200	Immediately	-	S	-
Pn321	Internal set speed 6	-6000 to 6000	rpm	-300	Immediately	-	S	-
Pn322	Internal set speed 7	-6000 to 6000	rpm	500	Immediately	-	S	-

NOTE: The servomotor's maximum speed will be used whenever a speed setting for the Pn316 to Pn322 exceeds the maximum speed.

Control Method Switching

Use ON/OFF combinations of the following input signals to operate with the internally set speeds.

When Pn005.1=2: Selects the internally set speed (contact reference) ↔ Speed control (zero reference)

/P-CON	/PCL	/NCL	Speed
OFF(H)	OFF (H)	OFF (H)	Speed control (zero reference)
	OFF (H)	ON (L)	SPEED1
	ON (L)	OFF (H)	SPEED2
	ON (L)	ON (L)	SPEED3
ON(L)	OFF (H)	OFF (H)	SPEED4
	OFF (H)	ON (L)	SPEED5
	ON (L)	OFF (H)	SPEED6
	ON (L)	ON (L)	SPEED7

NOTE: OFF= High level; ON= Low level

When Pn005.1 = 3, /P-CON, /PCL, /NCL = OFF (H), switches to position control (pulse train reference)

/P-CON	/PCL	/NCL	Speed
OFF(H)	OFF(H)	OFF(H)	Position control (pulse train reference)
	OFF(H)	ON(L)	SPEED1
	ON(L)	OFF(H)	SPEED2
	ON(L)	ON(L)	SPEED3
ON(L)	OFF(H)	OFF(H)	SPEED4
	OFF(H)	ON(L)	SPEED5
	ON(L)	OFF(H)	SPEED6
	ON(L)	ON(L)	SPEED7

5.6 Position Control

5.6.1 Parameter Setting

Control Method Selection

Set the following parameters for position control using pulse trains.

Parameter No.	Setting	Meaning
Pn005	H - - 1 -	Position control (pulse train reference)

A block diagram for position control is shown as below.

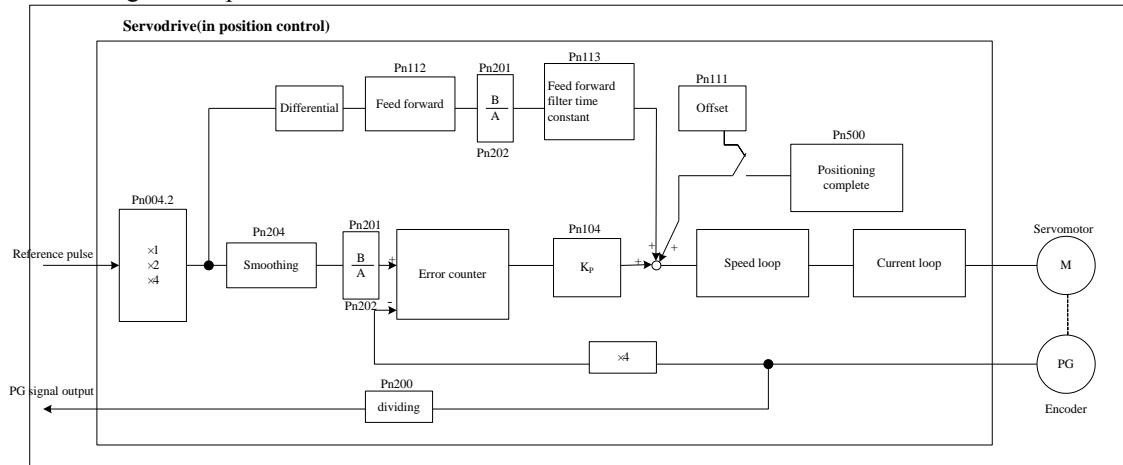

Setting a reference pulse sign

Type	Axis	Name	Pin No.	Meaning
Input	A, B, C	PULS+	CN1□-16	Reference pulse input
		PULS-	CN1□-15	Reference pulse input
		SIGN+	CN1□-18	Reference sign input
		SIGN-	CN1□-17	Reference sign input

Set the input form for the servo drive using parameter Pn004.2 according to the host controller specifications.

Parameter No.	Setting	Form	Multiplier	Forward Rotation	Reverse Rotation
Pn004	H-0--	Sign+pulse train (positive logic) (factory setting)	-	PULS SIGN	PULS SIGN
	H-1--	CW+CCW (positive logic)	-	CW CCW	CW CCW
	H-2--	Two-phase pulse train with 90° phase differential (positive logic)	×1	Phase-A Phase-B	Phase-A Phase-B
	H-3--		×2		
	H-4--		×4		

The input pulse multiplier can be set for the two-phase pulse train with 90° phase differential reference pulse form.

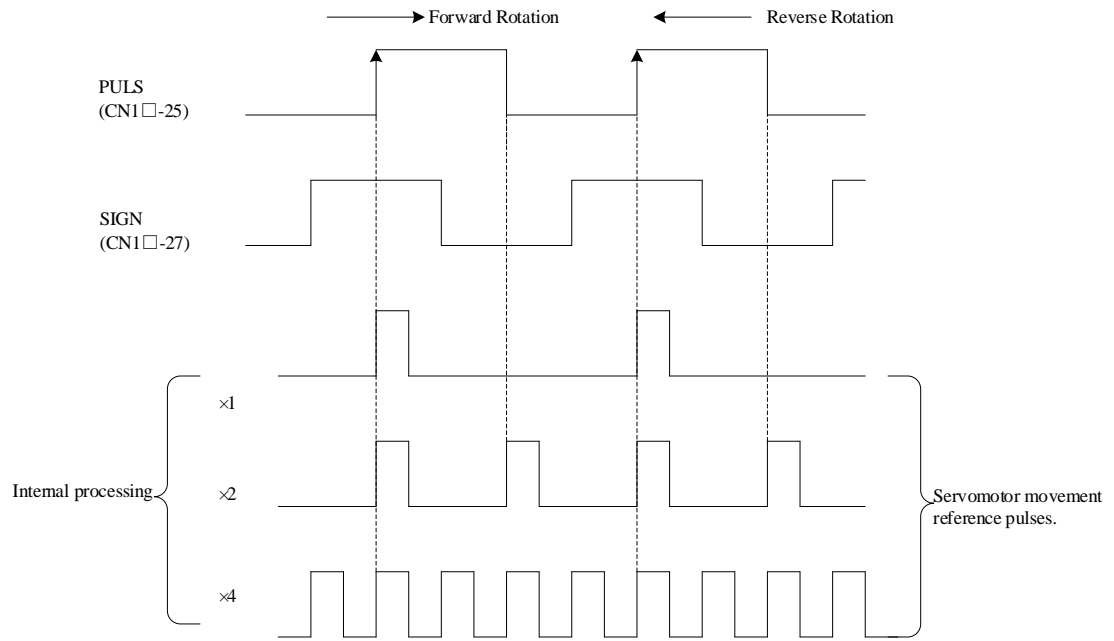

Inverse PULS and SIGN reference

Parameter No.	Setting	Meaning
Pn004	H 0 - - -	Do not inverse PULS reference and SIGN reference.
	H 1 - - -	Do not inverse PULS reference; Inverse SIGN reference
	H 2 - - -	Inverse PULS reference; Do not inverse SIGN reference
	H 3 - - -	Inverse PULS reference and SIGN reference

Reference Pulse Input Signal Timing

Reference pulse signal form	Electrical specifications	Remarks
Sign+pulse train input (SIGN+PULS signal) Maximum reference frequency: 500kpps (For open-collector output: 200kpps)	<p> $t1, t2=0.1\mu s$ $t3, t7=0.1\mu s$ $t4, t5, t6>3\mu s$ $t=1.0\mu s$ $(t/T)\times 100 = 50\%$ </p>	SIGN H=forward reference L=reverse reference
CW pulse+CCW pulse Maximum reference frequency: 500kpps (For open-collector output: 200kpps)	<p> $t1, t2=0.1\mu s$ $t3>3\mu s$ $t=1.0\mu s$ $(t/T)\times 100 = 50\%$ </p>	-

Reference pulse signal form	Electrical specifications	Remarks
Two-phase pulse train with 90° phase differential(phase A +B) Maximum reference frequency: ×1 input pulse multiplier: 500kpps ×2 input pulse multiplier: 400kpps ×4 input pulse multiplier: 200kpps	<p> $t_1, t_2=0.1\mu s$ $t=1.0\mu s$ $(t/T)\times 100 = 50\%$ </p>	A parameter Pn004.2 can be used to switch of the input pulse multiplier mode.

5.6.2 Clear Setting

Setting the Clear Signal

Type	Sign Name	Pin No.	Meaning
Input	/CLR	CN1□-25	Deviation counter clear

When the /CLR signal is set to low level, clear deviation counter:

- The error counter inside the Servodrive is set to“0”
- Position loop operation is disabled.

Setting the Clear Signal Mode

In position control mode, pulses will be still presented in the servo drive when servo OFF, thus it should be cleared when servo drive is turned ON. Setting Pn004 to choose whether clearing the pulses automatically when servo OFF.

Parameter No.	Setting	Meaning
Pn004	H - - 0 -	Clear the deviation count when Seveo OFF, but do not clear the deviation count when overtravel occurs.
	H - - 1 -	Never clear the deviation count.
	H - - 2 -	Clear the deviation count when Seveo OFF or overtravel occurs (except for zero clamp).

5.6.3 Electronic Gear Setting

Electronic Gear

The electronic gear enables the workpiece travel distance per input reference pulse from the host controller to be set to any value.

One reference pulse from the host controller, i.e., the minimum position data unit, is called a reference unit.

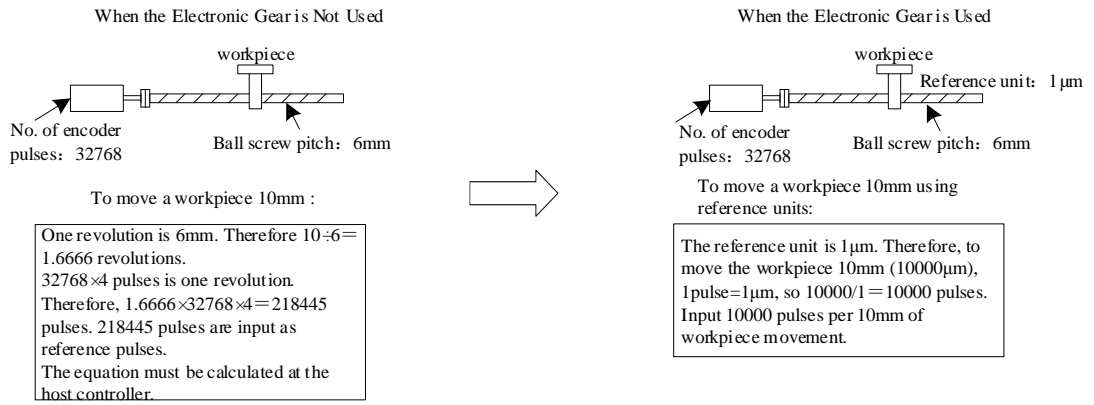

Relevant Parameters

Parameter No.	Setting	Meaning
Pn009	b - 0 - -	Use 16 bits electronic gear parameter
	b - 1 - -	Use 32 bits electronic gear parameter

Parameter No.	Name	Range	Unit	Default	When Enabled
Pn201	16 Bit Electronic Gear Ratio (Numerator)	1 to 65535	-	1	After restart
Pn317	16 Bit Electronic Gear Ratio (Denominator)	1 to 65535	-	1	After restart
Pn705	32 Bit Electronic Gear Ratio (Numerator, H)	1 to 9999	10000	0	After restart
Pn706	32 Bit Electronic Gear Ratio (Numerator, L)	1 to 9999	1	1	After restart
Pn707	32 Bit Electronic Gear Ratio (Denominator, H)	1 to 9999	10000	0	After restart
Pn708	32 Bit Electronic Gear Ratio (Denominator, L)	1 to 9999	1	1	After restart

The deceleration ratio of the servomotor and the load shaft is given as n/m where m is the rotation of the servomotor and n is the rotation of the load shaft.

$$\text{Electronic gear ratio } \frac{B}{A} = \frac{Pn201}{Pn202} = \frac{\text{Encoder resolution} \times 4}{\text{Travel distance per load shaft revolution (reference units)}} \times \frac{m}{n}$$

- When 32 bit electronic gear function is enabled, $\frac{B}{A} = \frac{Pn705 \times 10000 + Pn706}{Pn707 \times 10000 + Pn708}$
- If the ratio is outside the setting range, reduce the fraction (both numerator and denominator) until you obtain integers within the range.
- Note that do not change the electronic gear ratio (B/A).

**IMPORTANT**

- Electronic gear ratio setting range: $0.01 \leq \text{electronic gear ratio}(B/A) \leq 100$
- If the electronic gear ratio is outside this range, the servo drive will not operate properly. In this case, modify the load configuration or reference unit.

Procedure for Setting the Electronic Gear Ratio

Use the following procedure to set the electronic gear ratio.

- Step 1** Check machine specifications.
Check the deceleration ratio, ball screw pitch and pulley diameter.
- Step 2** Check the number of encoder pulses.
Check the number of encoder pulses for the servomotor used.
- Step 3** Determine the reference unit used.
Determine the reference unit from the host controller, considering the machine specifications and positioning accuracy.
- Step 4** Calculate the travel distance per load shaft revolution.
Calculate the number of reference units necessary to turn the load shaft one revolution based on the previously determined reference units.
- Step 5** Calculate the electronic gear ratio.
Use the electronic gear ratio equation to calculate the ratio (B/A).
- Step 6** Set parameters.
Set parameters using the calculated values.

----End

Electronic Gear Ratio Setting Examples

The following examples show electronic gear ratio settings for different load configurations.

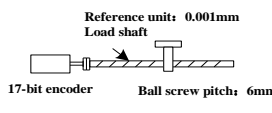
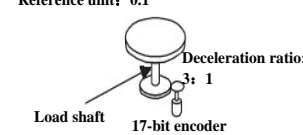
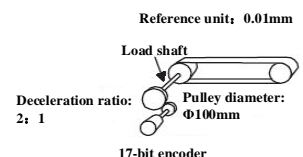
Step	Operation	Load Configuration		
		Ball Screw 	Disc Table 	Belt and Pulley 
1	Check machine specifications.	<ul style="list-style-type: none"> • Ball screw pitch:6mm • Deceleration ratio:1/1 	<ul style="list-style-type: none"> • Rotation angle per revolution:360° • Deceleration ratio:3/1 	<ul style="list-style-type: none"> • Pulley diameter:100 mm (pulley circumference:314 mm) • Deceleration ratio:2/1
2	Encoder	17-bit:32768P/R	17-bit:32768P/R	17-bit:32768P/R
3	Determine the reference unit used	1 reference unit: 0.001mm(1μm)	1 reference unit:0.1°	1 reference unit:0.01mm
4	Calculate the travel distance per load shaft revolution	6mm/0.001mm=6000	360° /0.1° =3600	314mm/0.01mm=31400
5	Calculate the electronic gear ratio	$\frac{B}{A} = \frac{32768 \times 4}{6000} \times \frac{1}{1}$	$\frac{B}{A} = \frac{32768 \times 4}{3600} \times \frac{3}{1}$	$\frac{B}{A} = \frac{32768 \times 4}{31400} \times \frac{2}{1}$

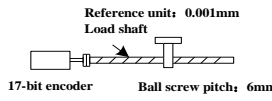
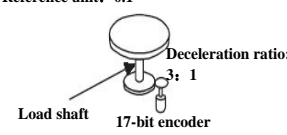
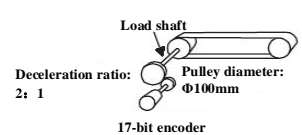
Step	Operation	Load Configuration		
		Ball Screw	Disc Table	Belt and Pulley
		Reference unit: 0.001mm Load shaft  17-bit encoder Ball screw pitch: 6mm	Reference unit: 0.1°  Load shaft 17-bit encoder Deceleration ratio: 3: 1	Reference unit: 0.01mm  Load shaft Deceleration ratio: 2: 1 Pulley diameter: Φ100mm 17-bit encoder
6	Set parameters	Pn201 = 131072 Pn202 = 6000	Pn201 = 393216 Pn202 = 3600	Pn201 = 262144 Pn202 = 31400
7	Final result	Pn201 = 32768 Pn202 = 1500	Pn201 = 32768 Pn202 = 300	Pn201 = 32768 Pn202 = 3925

Reduce the fraction (both numerator and denominator) if the calculated result will not be within the setting range.

For example, reduce the above numerators and denominators by four or other numbers to obtain the final results in step 7 and complete the settings.

Electronic Gear Ratio Equation

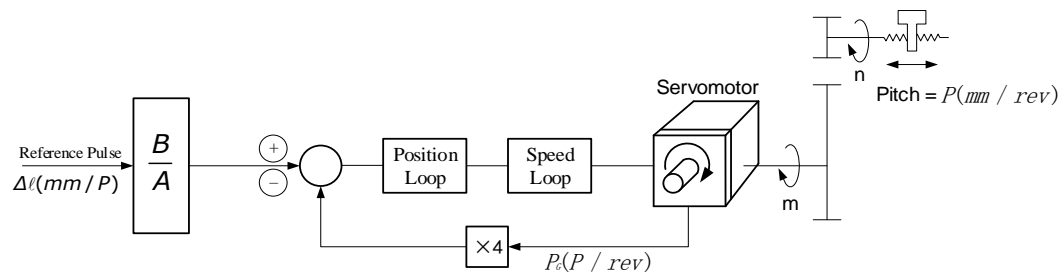

In which, $\Delta\ell$ is reference unit; P_G is encoder pulse; P is ball screw pitch; $\frac{m}{n}$ is deceleration ratio.

$$\frac{n \times P}{\Delta\ell} \times \frac{B}{A} = 4 \times P_G \times m \Rightarrow \frac{B}{A} = \frac{4 \times P_G \times m \times \Delta\ell}{n \times P} = \frac{4 \times P_G}{\frac{P}{\Delta\ell}} \times \frac{m}{n}$$

Set A and B by Pn202 and Pn201.

5.6.4 Smoothing

A filter can be applied in the servo drive to a constant-frequency reference pulse.

Selecting a Position Reference Filter

Parameter No.	Meaning
Pn205	0: 1st-order filter
	1: 2nd-order filter

NOTE: After changing the parameter, turn OFF the power once and turn it ON again to enable the new setting.

Relevant Parameters

Parameter No.	Name	Range	Unit	Default	When Enabled	Related Control		
Pn204	Position Reference Acceleration/Deceleration Time Constant	0 to 32767	0.25ms	0	Immediately	P	-	-



IMPORTANT

When the position reference acceleration/deceleration time constant (Pn204) is changed, a value with no reference pulse input and a position error of 0 will be enabled. To ensure that the setting value is correctly reflected, stop the reference pulse from the host controller and input the clear signal (CLR), or turn OFF to clear the error.

This function provides smooth servomotor operation in the following cases.

- When the host controller that outputs a reference that cannot perform acceleration/deceleration processing.
- When the reference pulse frequency is too low.
- When the reference electronic gear ratio is too high (i.e., 10× or more)

5.6.5 Low Frequency Vibration Suppression

Function Description

For the low rigidity load, low frequency vibration will occur continually at the front end of the load during fast acceleration or fast deceleration. The vibration may delay positioning time and affect the productive efficiency.

The function of low frequency vibration suppression is embedded in the Servodrives by calculating the load position and compensating.

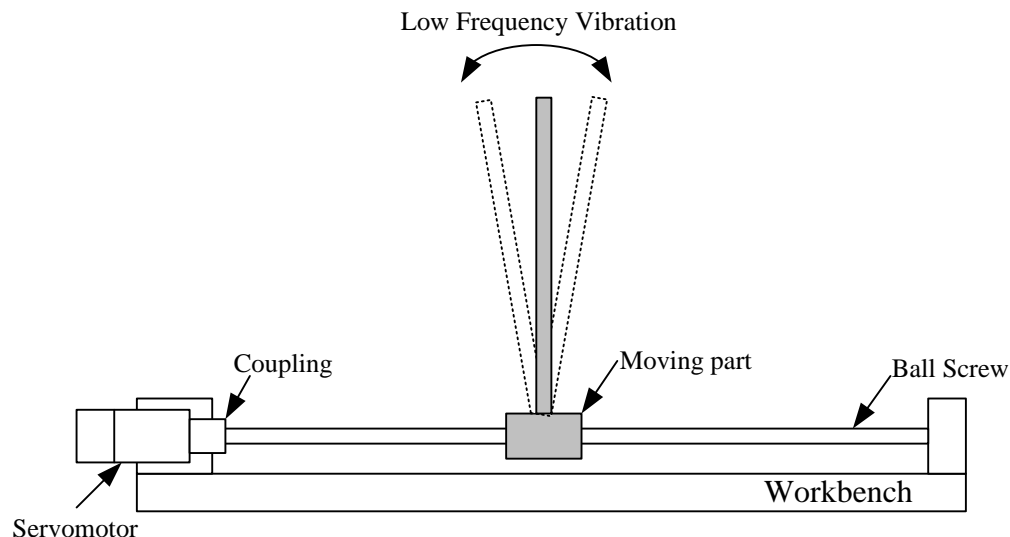

Applicable Range

Low frequency vibration suppression function is enabled in both speed control mode and position control mode.

Low frequency vibration suppression function is disabled or can not reach the expected effect in the following conditions.

- Vibration is picked up due to an external force.

- Vibration frequency is between 5.0Hz to 50.0Hz.
- There is mechanical clearance at the mechanical connection part.
- The time for movement is less than one vibration period.

Measuring Vibration frequency

Write the frequency data measured(unit:0.1Hz) directly to Parameter Pn411, if the vibration frequency can be measured by an instrument (such as a laser interferometer).And it also can be measured indirectly by communication software ESView or FFT analysis function.

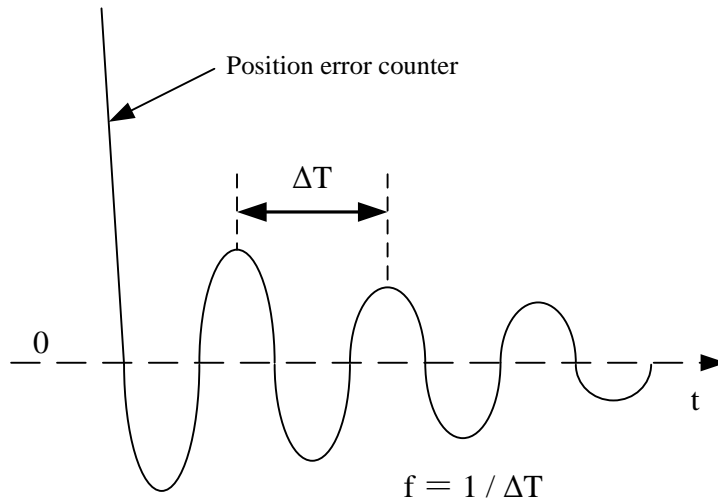

Related Parameters

Parameter No.	Setting	Meaning
Pn006	H-0--	Low frequency vibration suppression function disabled
	H-1--	Speed low frequency vibration suppression function enabled
	H-2--	Position low frequency vibration suppression function enabled

Parameter No.	Name	Range	Unit	Default	When Enabled	Related Control		
Pn411	Low frequency vibration frequency	50 to 500	0.1Hz	100	Immediately	P	S	-
Pn412	Low frequency vibration damp	0 to 200	-	25	Immediately	P	S	-

Writing the frequency data to parameter Pn411 can adjust Pn411 slightly to obtain the best suppression effect.

If the servomotor stopped with continuous vibration, Pn412(Do not change in general) should be increased properly.

Parameter Pn411 and Pn412 are enabled when Pn006.2=1 or 2(Setting validation: after restart).

5.6.6 Positioning Completion Output Signal

This signal indicates that servomotor movement has been completed during position control. Use the signal as an interlock to confirm that positioning has been completed at the host controller.

Type	Signal	Pin No.	Setting	Measning
Output	/COIN	CN1□-7, 8 [Factory Setting]	ON (low level)	Positioning has been completed.
			OFF (high level)	Positioning hasnot been completed.

NOTE: This output signal can be allocated to an output terminal with parameter Pn511. Refer to the section **3.2.3 Names and Functions**.

Parameter No.	Name	Range	Unit	Default	When Enabled	Related Control		
Pn500	Positioning Error	0 to 5000	1 Pulse	10	Immediately	P	-	-
Pn520	Position complete time	0 to 60000	0.25ms	200	Immediately	P	-	-

The positioning completion (/COIN) signal is output when the difference (position error pulse) between the number of reference pulses output by the host controller and the travel distance of the servomotor is less than the value set in this parameter and the stabilization time is more than the value of Pn520.

Set the number of error pulses in reference unit (the number of input pulses defined using the electronic gear).

Too large a value at this parameter may output only a small error during low-speed operation that will cause the /COIN signal to be output continuously.

The positioning error setting has no effect on final positioning accuracy.

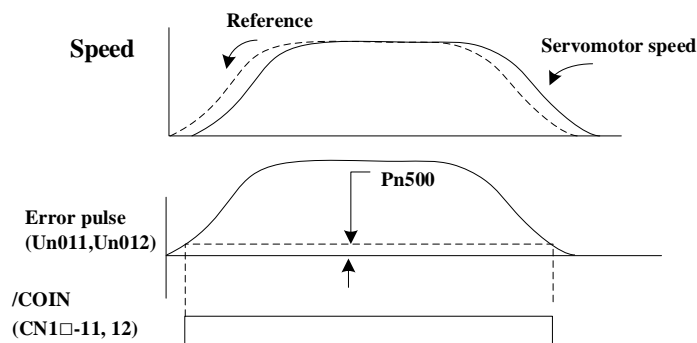

NOTE

- /COIN is a position control signal.
- This signal is used for the speed coincidence output /V-CMP for speed control, and it always OFF(high level) for torque control.

5.6.7 Reference Pulse Inhibit Function(INHIBIT)

Function Description

This function inhibits the servo drive from counting input pulses during position control.

The servomotor remains locked (clamped) while pulses are inhibited.

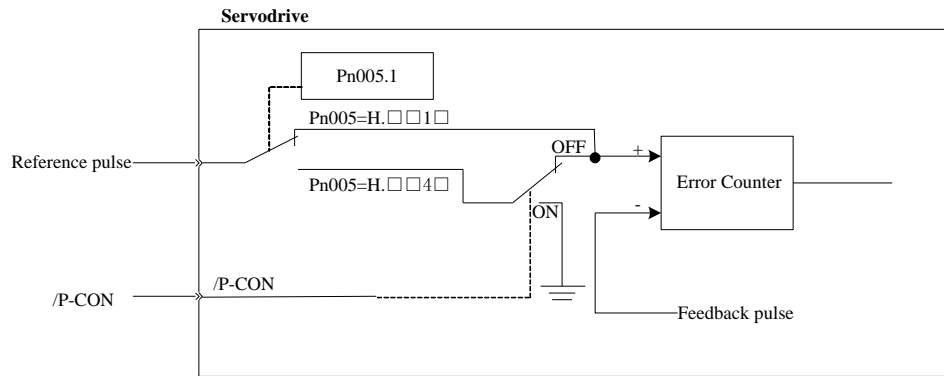

Parameter Setting

Parameter No.	Setting	Meaning
Pn005	H - - 4 -	Position control (pulse train reference) ↔ INHIBIT

Inhibit(INHIBIT) switching condition: /P-CON signal ON (low level)

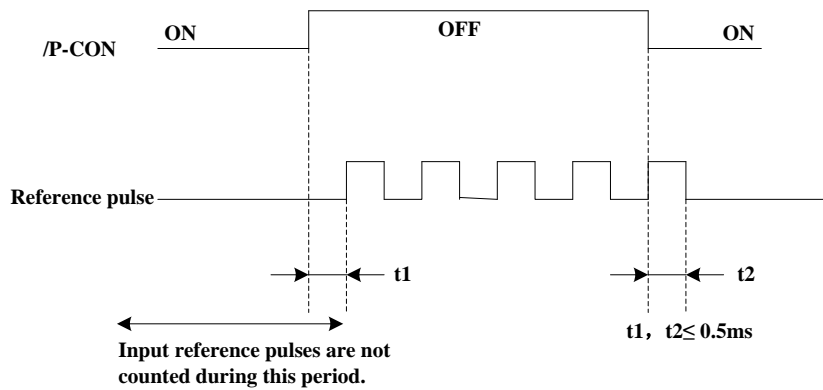

Signal Setting

Type	Signal Name	Pin Number	Setting	Measning
Input	/P-CON	CN1□-11	ON (low level)	Turns the INHIBIT function ON. (Inhibit the servo drive from countingreference pulses)
			OFF (high level)	Turns the INHIBIT function OFF. (Counters reference pulses.)

5.6.8 Position Control (contact reference)

Position control under contact reference (parameter Pn005.1 = 5). In this mode, servo drive can position with a single axes without a host controller.

There are 16 position control points with each being able to set move distance, running speed, constants for position reference filter time, and the stop time when positioning completed. Two speeds (1. speed moving toward distance switch "speed of looking for reference point". 2. Speed moving away from distance switch "moving speed.") of reference points could be set as:

- Two position modes: 1. Absolute position mode 2. Relative position mode
- Two running modes: 1. Circling mode 2. Non-circling mode
- Two step switching method: 1. Delay step switching 2. /P-CON signal switching

- Method of looking for reference points: 1. Forward direction 2. Reverse direction

Offset Adjustment

Offset of each points has two correspondent parameters: one unit of the parameter is [x 10000 reference pulse] and the other is [x 1 reference pulse]. Setting range of both parameters is: (-9999----+9999), while offset value equals sum of those two values.

For example: No.0 offset correspond to parameter Pn600 [x 10000 reference pulse] and Pn601[x 1 reference pulse]. Set Pn600 = 100, Pn601=-100.

$$\begin{aligned} \text{No.0 offset value} &= \text{Pn600} \times 10000 \text{ reference pulse} + \text{Pn601} \times 1 \text{ reference pulse} \\ &= 100 \times 10000 \text{ reference pulse} + (-100) \times 1 \text{ reference pulse} \\ &= 999900 \text{ reference pulse} \end{aligned}$$

With the same principle, we can conclude: in order to get the same results, we also can set
Pn600 = 99, Pn601 = 9900

Thus, we can see when the two parameters are not zero; we can get same result by two ways: one is to set the two parameters both negative or both positive, or one negative the other positive.

Speed

Speed mentioned here refers to the steady speed during which the motor is running, which is similar to the pulse frequency given from the external pulse reference in position control. However, this speed has nothing to do with the electronic gear; it is the actual speed of the motor.

Position reference filter time constant

Same as position reference filter time constant Pn204 in common position control.

Time for change steps after desired position reached

Apply internal delay to change steps to a valid value in parameter Pn681.1.

Time for change steps outputs from positioning completed signal CON/, from Servo ON, or from the time when reference point is found till the Servo performs the program to control position of the point. Such period of time depends on step changing time required by a point number among start point in program.

When running point control program, if error counter is set as “not clear error counter when Servo OFF”, then the error counter might flood. If it does not flood, then the servo drive will probably run at the max. running speed when Servo ON again. **PLEASE PAY ATTENTION TO THE SAFETY OF INSTRUMENT.**

Parameter No.	Name and description	Unit	Range	Default
Pn004.1	[0] Clear error pulse when S-OFF, not clear error pulse when overtravel. [1] Not clear error pulse [2] Clear error pulse When S-OFF or over travel	-	0 to 2	0

Looking for the reference point

Looking for the reference point is for establishing a zero physical point of the operating platform, which is used as zero point in the coordinates during point position control. And users may choose to find a reference point either in forward or reverse side.

- How to find a reference point
Mount a limit switch in the forward or reverse side. Find a reference point in the forward direction after connecting to /PCL and in the reverse direction after connecting to /NCL. When the operating platform bumps into the limit the switch, the motor will first stop according to the way set by Pn004.0,

and then rotate again against limit the switch. When the operating platform leaves the limit switch and the motor reaches the position of first photo encoder Phase C pulse, then position of operating platform is set to be the zero point of the coordinates.

- How to find Relevant parameters of reference point
Speed towards limit switch is called “speed of looking for reference point “, and the moving speed away from limit switch is called “ moving speed”. These two speeds could be set by the following parameters:

Parameter No.	Description	Unit	Range	Default
Pn685	Speed of looking for reference point (hits the limit switch)	rpm	0 to 3000	1500
Pn686	Moving speed (move away from limit switch)	rpm	0 to 200	30

Usually, the set speed of the reference point (Pn685) is high, and the moving speed (Pn686) is low. Note: if moving speed is too high, precision of finding a reference point would be affected.

When looking for a reference point, /PCL and /NCL are no longer programmed to limit external current.

Relevant parameter

Parameter No.	Function	Description
Pn681.0	Choose between cycle run and single run. [0] Cycle run, /PCL as start signal, /NCL reverse to look for reference point. [1] Single run, /PCL as start signal, /NCL reverse to look for reference point. [2] Cycle run, /NCL as start signal, /PCL reverse to look for reference point. [3] Single run, /NCL as start signal, /PCL reverse to look for reference point.	Changing steps will be performed till the end point is completed comma and the next change will start from the start point during multi-points cycle run. Point control program will not change steps after the end point is completed during multi- points single run.
Pn681.1	Change step and start mode [0] Delay changing steps, the start signal is not needed. [1] Change steps by /P-CON, start signal not needed. [2] Delay changing steps, need start signal. [3] Change steps by /P-CON, need start signal.	Change steps by external /P-CON signals. The signal will be valid when drive output reaches the desired position. When input signal changes, the signal is valid, then steps will be changed by consequence from start point to end point.
Pn681.2	Change step input signal mode [0] High or low level [1] Sign pulse	–
Pn682	[0] Incremental [1] Absolute	Incremental: relative moving distance (distance from current point to next point) programming. Absolute: absolute moving distance (distance between operating platform and the reference point) programming.

5.6.9 Internal Homing Function

The servomotor always needs to operate at a fixed position. This position is normally regarded as the zero position. When the host controller is turned on, the zero position adjustment is required before processing.

This zero position will be regarded as the reference point. ESTUN servo drives can perform this function by the homing function.

Homing Mode Setting

Parameter No.	Setting	Meaning
Pn689	b - - - 0	Homing in the forward direction
	b - - - 1	Homing in the reverse direction
	b - - 0 -	Return to search C-Pulse when homing
	b - - 1 -	Directly search C-Pulse when homing
	b - 0 - -	Homing function disabled
	b - 1 - -	Homing triggered by SHOM signal(rising edge)

NOTE:

Applicable control mode: position control(contact reference) ↔ speed control(contact reference)

Homing operation can only be operated when /COIN is ON.

Pulses sent from the host controller is disabled when homing

Homing operation is disabled when in switching control mode.

Control mode switching is not allowed during homing.

After changing these parameters, turn OFF the main circuit and control power supplies and then turn them ON again to enable the new settings.

A parameter can be used to re-allocate input connector number for the SHOM and ORG signals.

Relevant Parameters

Parameter No.	Name	Range	Unit	Default	When Enabled
Pn685	Speed of finding reference point(Hitting the origin signal ORG)	0 to 3000	Rpm	1500	Immediately
Pn686	Speed of finding reference point(Leaving the origin signal ORG)	0 to 200	rpm	30	Immediately
Pn690	Number of error pulses during homing	0 to 9999	10000 Pulses	0	Immediately
Pn691	Number of error pulses during homing	0 to 9999	1 Pulse	0	Immediately

Input Signal Setting

Type	Signal Name	Pin No.	Setting	Meaning
Input	SHOM	Allocated by Pn509, Pn510	ON (rising edge)	Homing is enabled
			OFF(not rising edge)	Homing is disabled
Input	ORG (ZPS)	Allocated by Pn509, Pn510	ON (high level)	ORG is enabled
			OFF (low level)	ORG is disabled
Output	/HOME	Allocated by Pn511	ON (level level)	Homing completed
			OFF (high level)	

NOTE: After changing Pn509, Pn510 and Pn511 turn OFF the main circuit and control power supplies and then turn them ON again to enable the new settings.

Homing Operation Description

Please set Pn689 according to the actual operation in position control mode. When starting the homing function, the servomotor will run at the speed of Pn685 when detecting the rising edge of SHOM signal; the servomotor will run at the speed of Pn686 according to the setting of Pn689.1 when detecting the valid ORG signal.

When input ORG and the encoder C-Pulse is detected, the servo drive will begin to calculate the number of homing offset pulses. When offset pulses is completed, the servomotor stops and outputs homing completion signal /HOME, then homing control is completed.

Pn685 (Hitting the origin signal (ORG)) is usually set at high speed, Pn686 (Leaving the origin signal ORG) is usually set at low speed.

Please be attention that if Pn686 is setting too high, the precision of mechanical zero position will be affected.

After hitting the origin signal ORG, the motor will return to find C-pulse; the figure is shown as below:

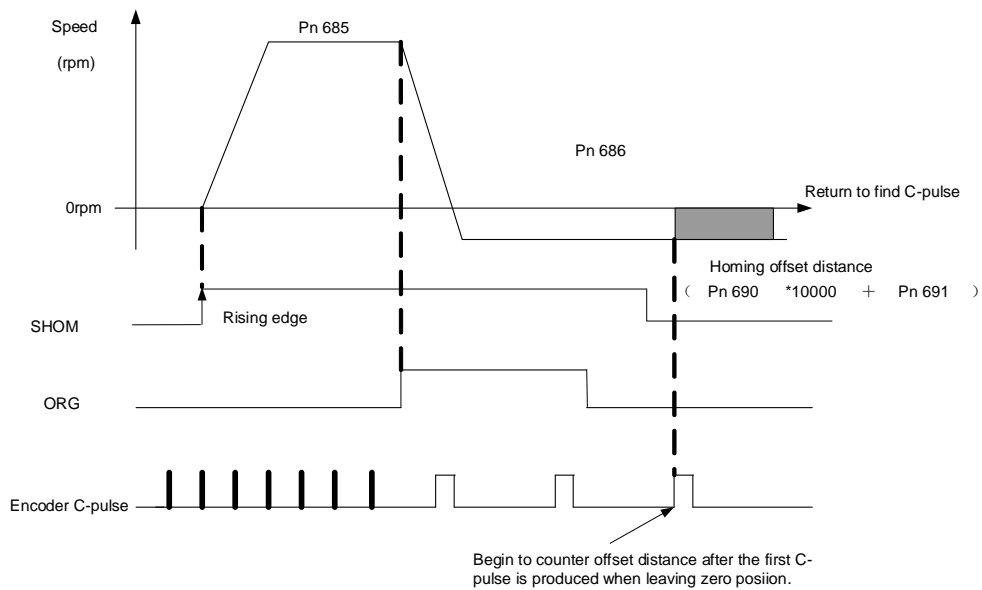

Corresponding position:

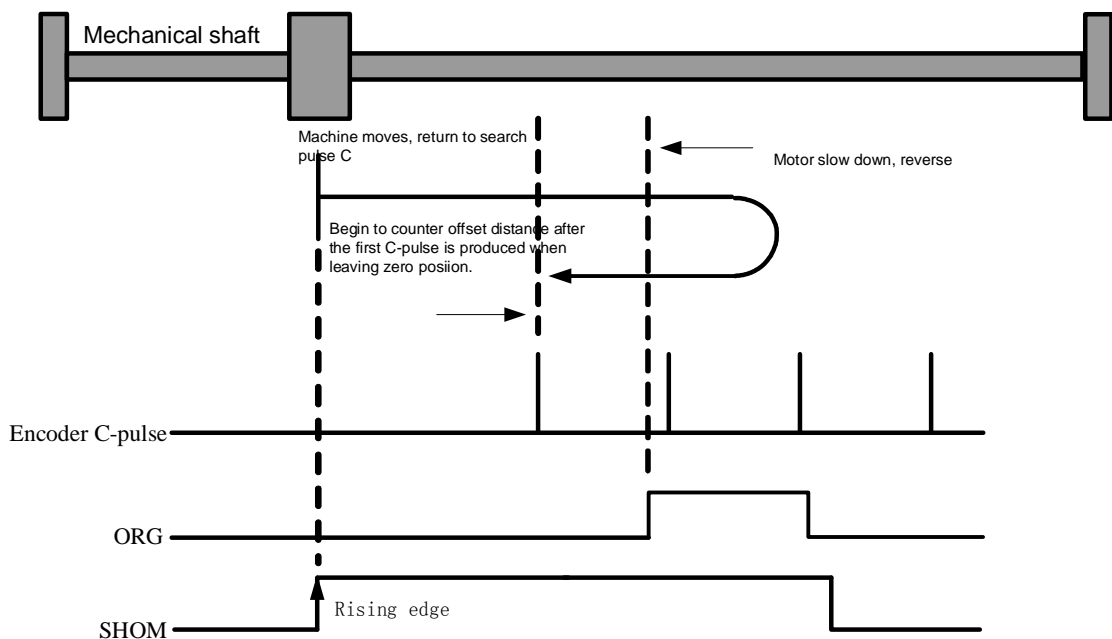

After hitting the origin signal ORG, the motor will find C-pulse directly; the figure is shown as below:

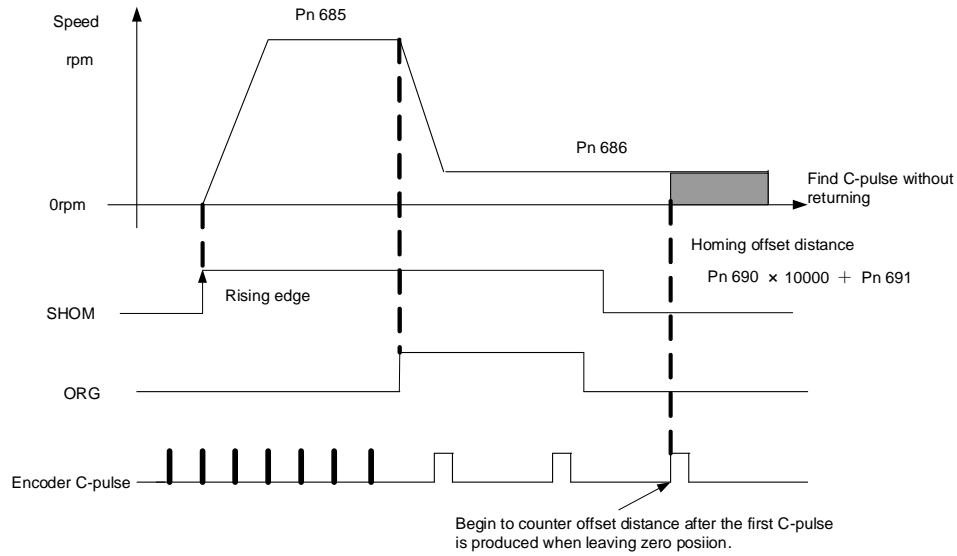

Corresponding position:

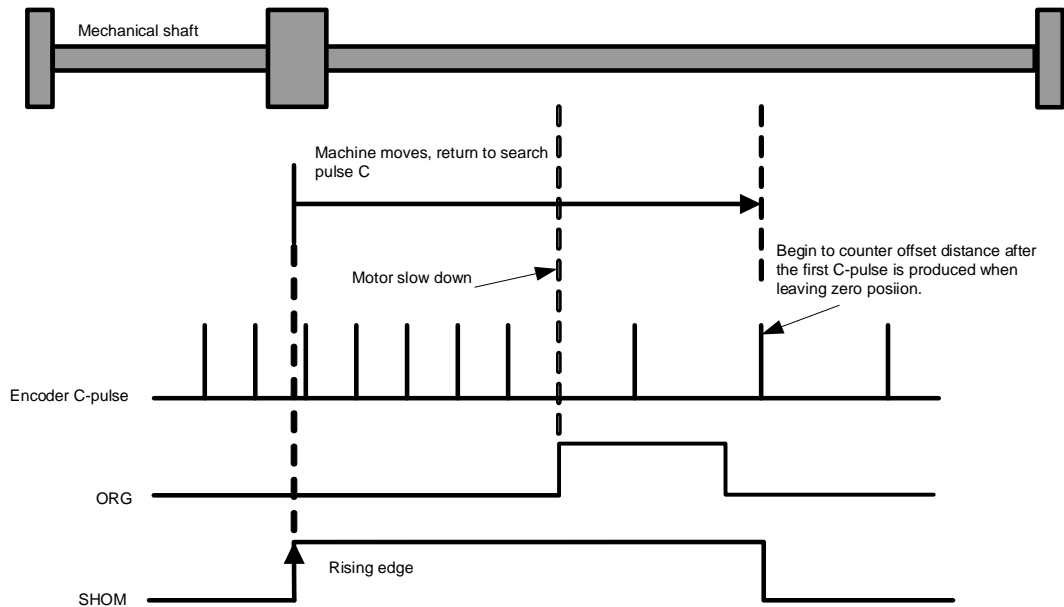

5.7 Torque Limit

The Servodrive provides internal torque limit/external torque limit for limiting output torque to protect the machine.

5.7.1 Internal Torque Limit

Maximum torque is always limited to the values set in the following parameters.

Parameter No.	Name	Range	Unit	Default	When Enabled	Related Control		
Pn401	Forward Torque Limit	0 to 300	%	300	Immediately	P	S	-
Pn402	Reverse Torque Limit	0 to 300	%	300	Immediately	P	S	-

The setting unit is a percentage of rated torque.

The maximum torque of the servomotor is used, even though the torque limit is set higher than the maximum torque of the servomotor. (as is the case with the 300% factory setting)

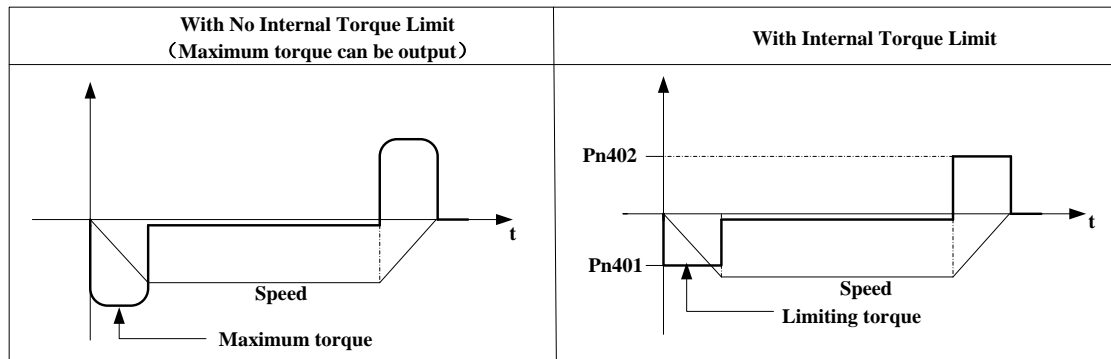

NOTE: Too small a torque limit setting will result in insufficient torque during acceleration and deceleration.

5.7.2 External Torque Limit

This function allows the torque to be limited at specific times during machine operation, for example, during press stops and hold operations for robot workpieces.

An input signal is used to enable the torque limits previously set in parameters.

Relevant Parameters

Parameter No.	Name	Range	Unit	Default	When Enabled	Related Control		
Pn403	Forward External Torque Limit	0 to 300	%	100	Immediately	P	S	-
Pn404	Reverse External Torque Limit	0 to 300	%	100	Immediately	P	S	-

NOTE: The setting unit is a percentage of rated torque (i.e., the rated torque is 100%).

Input Signals

Type	Signal Name	Allocation	Setting	Meaning	Limit Value
Input	/PCL	Pn509.0=6	ON (low level)	Forward external torque limit	Pn403
			OFF (high level)	Forward internal torque limit	Pn401
Input	/NCL	Pn509.0=7	ON (low level)	Reverse external torque limit	Pn404
			OFF (high level)	Reverse internal torque limit	Pn402

NOTE: When using this function, make sure that there are no other signals allocated to the same terminals as /P-CL and /N-CL.

Changes in Output Torque during External Torque Limiting

For example: External torque limit (Pn401, Pn402) set to 300%

/PCL	/NCL	
High level	High level	
High level	Low level	
Low level	High level	
Low level	Low level	

NOTE: Select the servomotor rotation direction by setting Pn001=b -- -- 0 (standard setting, CCW=Forward direction).

5.8 Other Output Signals

5.8.1 Servo alarm output

The following diagram shows the right way to connect the Alarm Output.

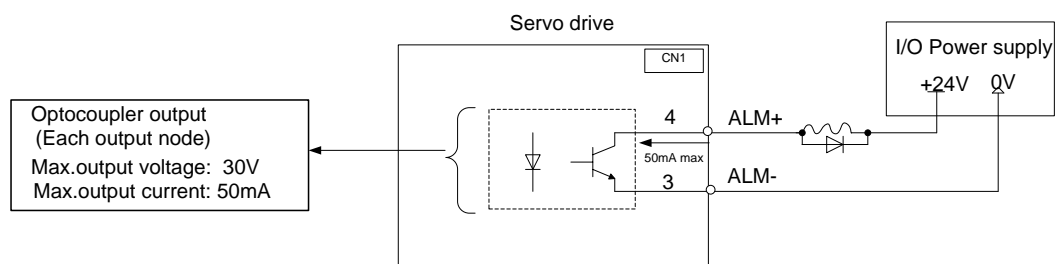

An external +24V I/O power supply is required since there is no +24V power source available inside the servo drive.

Output → ALM+	CN1□-4	Servo alarm output
---------------	--------	--------------------

 Output → ALM- CN1□-3

ALM outputs a signal when the servo drive is detected in an abnormal state.

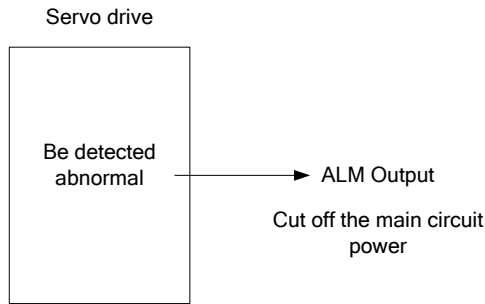

Normally, the external circuit consists of /ALM should be able to switch off the power of servo drive.

Signal	Status	Output Level	Description
ALM	ON	CN1□-4: Low level	Normal state
	OFF	CN1□-4: High level	Alarm state

When “servo alarm(ALM)” happens, always remove alarm reasons first , and then turn the input signal "/ALM-RST" to ON position to reset alarm status.

5.8.2 Others

Set Pn511.9 to allocate the desired output signal.

Pn511.0	SignalName	Connector PinNumber	Setting	Meaning
0	/COIN(/VCMP)	CN1□-7/8 CN1□-1/2 CN1□-5/6	ON=L	Positioning is complete.
			OFF=H	Positioning is not complete
1	/TGON	CN1□-7/8 CN1□-1/2 CN1□-5/6	ON=L	Servomotor is operating(Servomotor speed is above the setting in Pn503).
			OFF=H	Servomotor is not operating(Servomotor speed is below the setting in Pn503).
2	/S-RDY	CN1□-7/8 CN1□-1/2 CN1□-5/6	ON=L	Servo is ready.
			OFF=H	Servo is not ready.
3	/CLT	CN1□-7/8 CN1□-1/2 CN1□-5/6	ON=L	Motor output torque under limit (Internal torque reference is higher than setting value).
			OFF=H	No torque limit (Internal torque reference is lower than setting value).

Pn511.0	SignalName	Connector PinNumber	Setting	Meaning
4	/BK	CN1□-7/8 CN1□-1/2 CN1□-5/6	ON=L	Releases the brake.
			OFF=H	Applies the brake.
5	PGC	CN1□-7/8 CN1□-1/2 CN1□-5/6	ON=L	With encoder C pluse output
			OFF=H	Without encoder C pluse output
6	OT	CN1□-7/8 CN1□-1/2 CN1□-5/6	ON=L	Without forward rotation Prohibited(POT) and reverse rotation prohibited(NOT)signal
			OFF=H	With forward rotation Prohibited(POT)and reverse rotation prohibited(NOT)signal
7	/RD	CN1□-7/8 CN1□-1/2 CN1□-5/6	ON=L	Servo enabled motor excitation
			OFF=H	Servo disabled motor not excitation
8	/HOME	CN1□-7/8 CN1□-1/2 CN1□-5/6	ON=L	Homing is enabled
			OFF=H	Homing is disabled
9	/TCR	Not including this setting in the default setting,please choose terminal output by setting parameter Pn511	ON=L	Motor output torque is higher than Pn529 setting value.
			OFF=H	Motor output torque is lower than Pn529 setting value.

5.9 Online Autotuning

5.9.1 Function Description

Online autotuning calculates the load moment of inertia during operation of the servo drive and sets parameters so that the servo gains are consistent with the machine rigidity.

Online autotuning may not be effective in the following cases:

- The motor high speed is lower than 100 rpm.
- The motor acceleration or deceleration is lower than 5000rpm/s.
- Load rigidity is low and mechanical vibration occurs easily or friction is high.
- The speed load moment is changed greatly.
- Mechanical gas is very large.

If the condition meets one of the above cases or the desired operation cannot be achieved by the online autotuning, set the value in Pn106 (Load inertia percentage) and perform the adjustment manually.

5.9.2 Online Autotuning Procedure



- Do not perform extreme adjustment or setting changes causing unstable servo operation. Failure to observe this warning may result in injury and damages to the machine.
- Adjust the gains slowly while confirming motor operation.

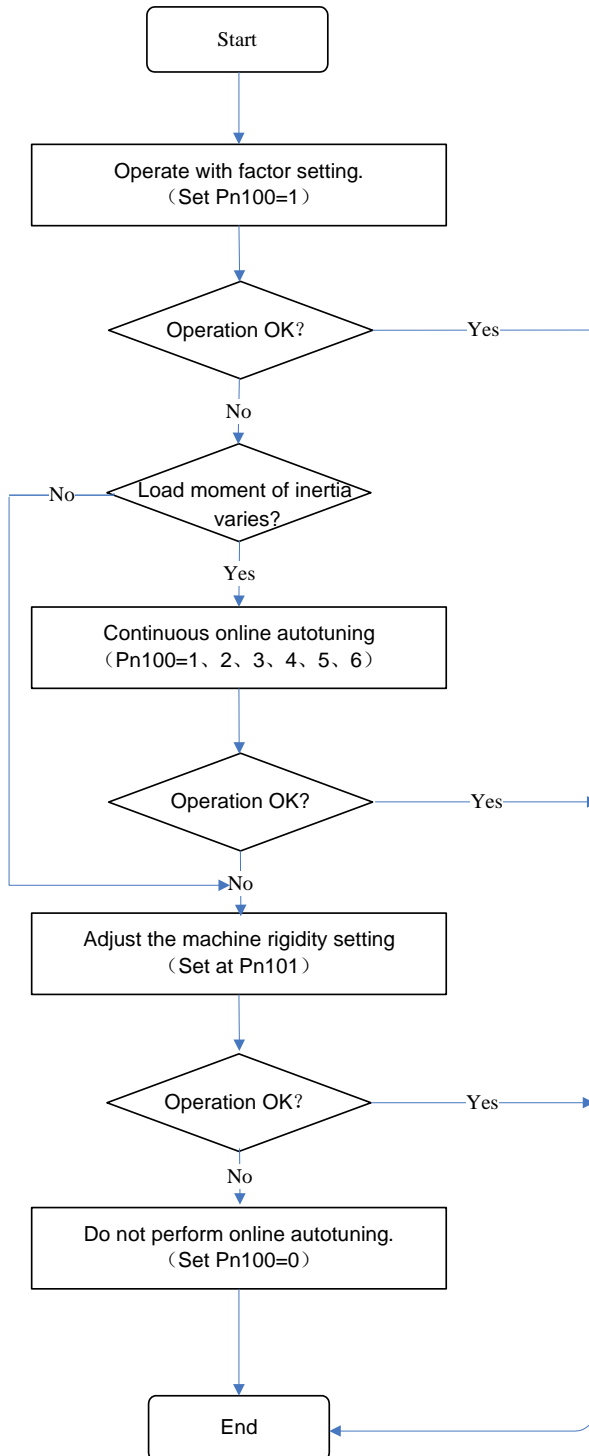

5.9.3 Setting Online Autotuning

Parameter No.	Description	Unit	Range	Default	When Enabled
Pn100	Online autotuning setting	–	0000 to 0006	0000	After restart
Pn101	Machine rigidity setting	–	0 to 15	5	Immediately
Pn128	Speed gain acceleration relationship during online autotuning. If the setting is greater, the servo gain will increase.	–	0 to 3	3	Immediately

5.9.4 Machine Rigidity Setting for Online Autotuning

There are 16 machine rigidity settings for online autotuning. When the machine rigidity setting is selected, the servo gains (speed loop gain, speed loop integral time constant, position loop gain) are determined automatically. The factory setting for the machine rigidity setting is 5.

Machine Rigidity Setting	Position Loop Gain [s ⁻¹] Pn104	Speed Loop Gain [Hz] Pn102=Pn104*(Pn128+1)	Speed Loop Integral Time Constant [0.25ms] Pn103
0	10	40	800
1	15	60	600
2	20	80	450
3	25	100	400
4	30	120	300
5	40	160	200
6	65	260	140
7	80	320	110
8	100	400	90
9	120	480	80
10	140	560	70
11	160	640	60
12	180	720	55
13	210	840	50
14	250	1000	40
15	300	1200	30

Chapter 6 CANopen Communication

6.1 Wiring and Connection

The terminal layout of CN3 and CN4 is as following:

Diagram	Pin	Name	Function
	1	–	Reserved
	2	–	
	3	485+	RS-485 communication terminal
	4	ISO_GND	Isolated GND
	5	ISO_GND	
	6	485-	RS-485 communication terminal
	7	CANH	CAN communication terminal
	8	CANL	CAN communication terminal

[NOTE] Do not short pin 1 and pin 2.
If you want to connect more than 16 slave-stations, please contact ESTUN.

CN3 is always the input terminal of communication cable and CN4 is always the output terminal of communication cable. (If connection to another communication node is necessary, the cable will connect CN4 to next communication node. If not, a terminal resistor could be applied at CN4). When multiple ED3M devices are connected, it is forbidden to connect the CN3 terminals of different drives directly.

For example, a network is composed of one PLC, three ProNet drives called A, B and C. The cabling network is as below:

PLC → CN3 of drive A, CN4 of drive A → CN3 of drive B, CN4 of drive B → CN3 of drive C, CN4 of drive C → 120Ω resistor.

The two ends of the CAN cable have to be terminated by a resistor of 120Ω (1%, 1/4W) as below.

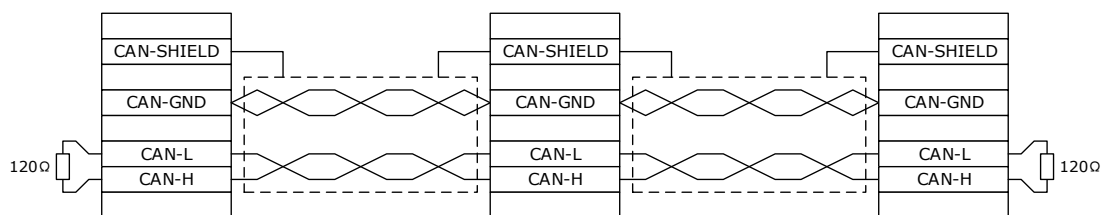

Please select the bus cable with double twisted pair cables and shielding layer, one pair for connecting CAN-L and CAN-H, another pair for grounding.

6.2 Messages Description

CAL supplies all network management service and message transferring protocol with defining the content of object or type of object for communication. It defines how instead of what, which is the strength of CANopen.

CANopen is developed based on CAL. It applies CAL protocol subsets for communication and service and creates a solution to DCS. CANopen could freely extend the node function to simplicity or complex while the network nodes are accessible and available to each other.

The key concept of CANopen is object dictionary. This way of object description is also applied to other fieldbus system like Profibus and Interbus-S. CANopen communication could access to all the parameter of drivers through object dictionary. Please notice object dictionary is not one part of CAL, instead of which it is realized in CANopen.

CANopen communication defines several types of objects as below.

Abbreviation	Full Name	Description
SDO	Service Data Object	Used for normal parameterization of the servo controller
PDO	Process Data Object	Fast exchange of process data (e.g. velocity actual value) possible.
SYNC	Synchronization Message	Synchronization of several CAN nodes
EMCY	Emergency Message	Used to transmit error messages of the servo controller.
NMT	Network Management	Used for network services. For example user can act on all controllers at the same time via this object type.
Heartbeat	Error Control Protocol	Used for observing all nodes by cyclic messages.

CAN employs data frames for transferring data between the host (controller) and the nodes on the bus. The following figure presents the structure of the data frame.

Head	Arbitration field		Control field	Data field	Check field	Response field	End
	COB-ID	RTR					
1 bit	11 bits or 29 bits	1 bit	6 bits	0 to 8 bits	16 bits	2 bits	7 bits

Our drivers doesn't support remote frame currently. The detail of COB-ID is as below.

Function code				Node ID						
10	9	8	7	6	5	4	3	2	1	0

6.2.1 CAN identifier list

Object	COB-ID bit10~7 (binary)	COB-ID (hex)	Index in OD
NMT	0000	000h	-
SYNC	0001	080h	1005h, 1006h, 1007h
TIME STAMP	0010	100h	1012h, 1013h
EMCY	0001	081h ~ 0FFh	1024h, 1015h
PDO1 (send)	0011	181h ~ 1FFh	1800h
PDO1 (receive)	0100	201h ~ 27Fh	1400h
PDO2 (send)	0101	281h ~ 2FFh	1801h
PDO2 (receive)	0110	301h ~ 37Fh	1401h
PDO3 (send)	0111	381h ~ 3FFh	1802h
PDO3 (receive)	1000	401h ~ 47Fh	1402h
PDO4 (send)	1001	481h ~ 4FFh	1803h

Object	COB-ID bit10~7 (binary)	COB-ID (hex)	Index in OD
PDO4 (receive)	1010	501 _h ~ 57F _h	1403 _h
SDO (send)	1011	581 _h ~ 5FF _h	1200 _h
SDO (receive)	1100	601 _h ~ 67F _h	1200 _h
Heartbeat	1110	701 _h ~ 77F _h	1016 _h , 1017 _h

[NOTE] PDO/SDO's send/receive is observed by (slave) CAN.

Our drive's CANopen protocol currently supports 4 transmit PDO and 4 receive PDO.

6.2.2 SDO

SDO is used to visit the object dictionary of a device. Visitor is called client. The CANopen device whose object dictionary is visited and required to supply the asked service is called server. CANopen messages from a client and servo all contain 8 bits (Not all of them are meaningful). A request from a client must be confirmed by a server

There are 2 method of conveying SDO:

- Expedited transfer: contains 4 bytes at maximum
- Segmented transfer: contains more than 4 bytes

Basic structure of SDO:

Byte0	Byte1~2	Byte3	Byte4~7
SDO	Object index	Object sub-index	Data

SDO read/write command structure:

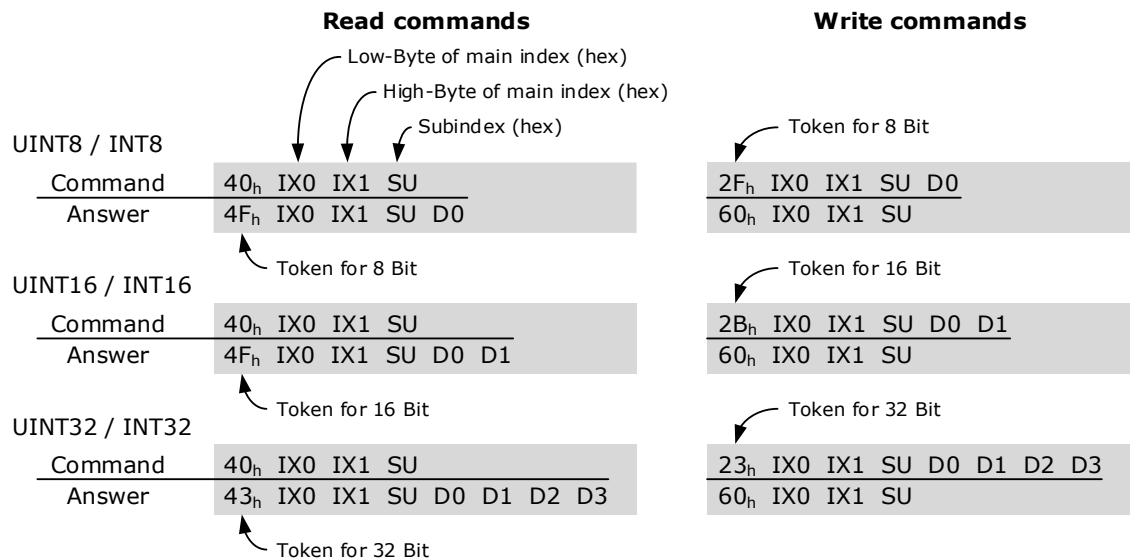

For example:

UINT8 / INT8		Reading of Obj. 6061_00 _h Returning data: 01 _h	Writing of Obj. 1401_02 _h Data: EF _h
Command	40 _h 61 _h 60 _h 00 _h	4F _h 61 _h 60 _h 00 _h 01 _h	2F _h 01 _h 14 _h 02 _h EF _h
Answer			60 _h 01 _h 14 _h 02 _h
UINT16 / INT16		Reading of Obj. 6041_00 _h Returning data: 1234 _h	Writing of Obj. 6040_00 _h Data: 03E8 _h
Command	40 _h 41 _h 60 _h 00 _h	4B _h 41 _h 60 _h 00 _h 34 _h 12 _h	2B _h 40 _h 60 _h 00 _h E8 _h 03 _h
Answer			60 _h 40 _h 60 _h 00 _h
UINT32 / INT32		Reading of Obj. 6093_01 _h Returning data: 12345678 _h	Writing of Obj. 6093_01 _h Data: 12345678 _h
Command	40 _h 93 _h 60 _h 01 _h	43 _h 93 _h 60 _h 01 _h 78 _h 56 _h 34 _h 12 _h	23 _h 93 _h 60 _h 01 _h 78 _h 56 _h 34 _h 12 _h
Answer			60 _h 93 _h 60 _h 01 _h

SDO-error messages:

Command	... IX0 IX1 SU
Answer	80 _h IX0 IX1 SU F0 F1 F2 F3

Error code				Description
F3	F2	F1	F0	
05	03	00	00 _h	Toggle bit not alternated
05	04	00	01 _h	Client/server command specifier not valid or unknown
06	01	00	00 _h	Unspported access to an object
06	01	00	01 _h	Attempt to read a write only object
06	01	00	02 _h	Attempt to write a read only object
06	02	00	00 _h	Object does not exist in the object dictionary
06	04	00	41 _h	Object cannot be mapped to the PDO
06	04	00	42 _h	The number and length of the objects to be mapped would exceed PDO length
06	04	00	47 _h	General internal incompatilby in the device
06	07	00	10 _h	Data type does not match, length of service parameter does not match
06	07	00	12 _h	Data type does not match, length of service parameter too high
06	07	00	13 _h	Data type does not match, length of service parameter too low
06	09	00	11 _h	Sub-index does not exist
06	04	00	43 _h	General parameter incompatibility
06	06	00	00 _h	Access failed due to an hardware error
06	09	00	30 _h	Value range of parameter exceeded
06	09	00	31 _h	Value of parameter written too high
06	09	00	32 _h	Value of parameter written too low
06	09	00	36 _h	Maximum value is less than minimum value
08	00	00	20 _h	Data cannot be transferred or stored to the application
08	00	00	21 _h	Data cannot be transferred or stored to the application because of local control

Error code				Description
F3	F2	F1	F0	
08	00	00	22 _h	Data cannot be transferred or stored to the application because of the present device state
08	00	00	23 _h	No Object Dictionary is present

6.2.3 PDO

PDO is applied to transferring real time data which will be conveyed from a producer to one or multiple clients. Data transferring will be limited to 1 to 8 bytes. There is no hand-shake restriction in PDO communication, which means data has been redefined, so clients could process the received data for vary short time. PDO content will be only defined by its CAN ID, assuming producers and clients know PDO content from its CAN ID.

Objects Description

Two objects in object dictionary are used for each PDO.

- PDO communication parameter: It contains COB-ID, transferring type, restriction time and cycle of timer used by PDO.
- PDO mapping parameter: It contains a list of objects in the object dictionary. These objects are mapped into PDO, includes their data length in bits. Producers and clients must know this mapping to explain the content of PDO.

The content of PDO's message is predefined or configured when the network initializes. Mapping application object into PDO is described in object dictionary. If a device (producer and client) support dynamic mapping, SDO could be used to configure PDO's mapping parameter. Our servo drive supports dynamic PDO mapping. There are 2 rules for PDO mapping to follow.

- Each PDO could be mapped into 4 objects.
- The length of each PDO will be no more than 64 bits.

Mapping Process

1. Set the sub-index of PDO coordinated mapping parameter (1600_h, 1601_h, 1A00_h or 1A01_h) as 0.
2. Revise the sub-index from 1 to 4 of PDO coordinated mapping parameter (1600_h, 1601_h, 1A00_h or 1A01_h).
3. Set the sub-index 0 of PDO coordinated mapping parameter(1600_h, 1601_h, 1A00_h or 1A01_h) as legal number(number of PDO's mapping objects)
4. PDO mapping was completed.

Transmit Type

- Synchronous (Synchronization by receiving SYNC object)
Cycle: Transmit triggered after every 1 to 240 SYNC messages.
- Asynchronous
Transmit triggered by special object event regulated in sub-object protocol.

Transmit Type List

Value	Description	PDO
0	Reserved	-
1~240	SYNC: It represents the number of SYNC objects between 2 PDOs.	TPDO/RPDO
240~253	Reserved	-

Value	Description	PDO
254	Asynchronous: If the content of PDO has changed, PDO transmit will be triggered.	TPDO
255	Asynchronous: The content of PDO will be periodically updated and transmitted.	TPDO/RPDO

One PDO could set a frozen time which is the shortest interval time between 2 continuous PDO. It could prevent the bus from being occupied by amount of data with high priority. Frozen time is defined by 16 bit unsigned integer number and its unit is 100us.

One PDO could set a timing period. When the regulated time is violated, a PDO transmit could be triggered without a trigger bit. Object timing period is defined as 16 bit unsigned integer and its unit is 1ms.

Mapping Case

Map the 3 objects to PDO1 (transmit). PDO1 (transmit) is required to be asynchronous periodic type with period time as much as 10ms and frozen time as much as 2ms.

Object	Index – Sub-index	Description
Statusword	6041h – 00 h	Status word
modes_of_operation_display	6061h – 00 h	Practical operational mode
Position_Actual_Value	6064h – 00 h	Practical position

1. Clear number_of_mapped_objects
number_of_mapped_objects(1A00 h: 00 h) = 0
2. Set the parameter for mapping objects
Index =6041 h Subin. = 00h Length = 10 h ⇒ 1st_mapped_object(1A00 h: 01 h)= 60410010 h
Index =6061 h Subin. = 00h Length = 08 h ⇒ 2st_mapped_object(1A00 h: 02 h)= 60610008 h
Index =60FD h Subin. = 00h Length = 20 h ⇒ 3st_mapped_object(1A00 h: 03 h) = 60FD0020 h
3. Set number_of_mapped_objects
number_of_mapped_objects(1A00 h: 00 h)= 3
4. Set PDO communication parameters
PDO1 (transmit) is asynchronous periodical type ⇒ transmission_type (1800 h: 02 h)= FF h
Frozen time 2ms(20×100us) ⇒ inhibit_time (10A0 h: 03 h)= 14 h
Period time: 10ms(10×1ms) ⇒ event_time (1800 h: 05 h)= 0A h
5. PDO mapping was completed.

PDO Parameter

ED3M drive contains 4 transmit PDOs and 4 receive PDOs. The detailed communication parameter and mapping parameter of the first transmit/receive PDO is as below and those of the rest 3 transmit/receive PDO are the same as the first PDO.

Index	1800 h
Name	transmit_pdo_parameter_tpdo1
Object Code	RECORD
No. of Elements	4

Sub-Index	01 h
Description	cob_id_used_by_pdo_tpdo1

Sub-Index	01 h
Data Type	UINT32
Access	RW
PDO Mapping	NO
Units	–
Value Range	181 h...1FF h, Bit 31 may be set
Default Value	181 h

Sub-Index	02 h
Description	transmission_type_tpdo1
Data Type	UINT8
Access	RW
PDO Mapping	NO
Units	–
Value Range	1...240,254,255
Default Value	255

Sub-Index	03 h
Description	inhibit_time_tpdo1
Data Type	UINT16
Access	RW
PDO Mapping	NO
Units	100μs
Value Range	–
Default Value	100

Sub-Index	05 h
Description	event_time_tpdo1
Data Type	UINT16
Access	RW
PDO Mapping	NO
Units	1ms
Value Range	–
Default Value	10

Index	1A00 h
Name	transmit_pdo_mapping_tpdo1
Object Code	RECORD
No. of Elements	2

Sub-Index	00 h
Description	number_of_mapped_objects_tpdo1
Data Type	UINT8
Access	RW
PDO Mapping	NO
Units	–
Value Range	0..4
Default Value	2

Sub-Index	01 h
Description	first_mapped_object_tpdo1
Data Type	UINT32
Access	RW
PDO Mapping	NO
Units	–
Value Range	–
Default Value	See the table

Sub-Index	02 h
Description	second_mapped_object_tpdo1
Data Type	UINT32
Access	RW
PDO Mapping	NO
Units	–
Value Range	–
Default Value	See the table

Sub-Index	03 h
Description	third_mapped_object_tpdo1
Data Type	UINT32

Sub-Index	03 _h
Access	RW
PDO Mapping	NO
Units	–
Value Range	–
Default Value	See the table

Sub-Index	04 _h
Description	fourth_mapped_object_tpdo1
Data Type	UINT32
Access	RW
PDO Mapping	NO
Units	–
Value Range	–
Default Value	See the table

- T-PDO1

Index	Comment	Type	Acc.	Default Value
1800 _h _00 _h	number of entries	UINT8	RO	04 _h
1800 _h _01 _h	COB-ID used by PDO	UINT32	RW	00000181 _h
1800 _h _02 _h	transmission type	UINT8	RW	FF _h
1800 _h _03 _h	inhibit time (100 μs)	UINT16	RW	64 _h
1800 _h _05 _h	event time (1ms)	UINT16	RW	0A _h
1A00 _h _00 _h	number of mapped objects	UINT8	RW	02 _h
1A00 _h _01 _h	first mapped object	UINT32	RW	60410010 _h
1A00 _h _02 _h	second mapped object	UINT32	RW	60640020 _h
1A00 _h _03 _h	third mapped object	UINT32	RW	00 _h
1A00 _h _04 _h	fourth mapped object	UINT32	RW	00 _h

- T-PDO2

Index	Comment	Type	Acc.	Default Value
1801 _h _00 _h	number of entries	UINT8	RO	04 _h
1801 _h _01 _h	COB-ID used by PDO	UINT32	RW	00000281 _h
1801 _h _02 _h	transmission type	UINT8	RW	FF _h
1801 _h _03 _h	inhibit time (100 μs)	UINT16	RW	64 _h
1801 _h _05 _h	event time (1ms)	UINT16	RW	0A _h

Index	Comment	Type	Acc.	Default Value
1A01 h_00 h	number of mapped objects	UINT8	RW	02 h
1A01 h_01 h	first mapped object	UINT32	RW	60640020 h
1A01 h_02 h	second mapped object	UINT32	RW	60610010 h
1A01 h_03 h	third mapped object	UINT32	RW	00 h
1A01 h_04 h	fourth mapped object	UINT32	RW	00 h

- T-PDO3

Index	Comment	Type	Acc.	Default Value
1802 h_00 h	number of entries	UINT8	RO	04 h
1802 h_01 h	COB-ID used by PDO	UINT32	RW	00000381 h
1802 h_02 h	transmission type	UINT8	RW	FF h
1802 h_03 h	inhibit time (100 μ s)	UINT16	RW	64 h
1802 h_05 h	event time (1ms)	UINT16	RW	0A h
1A02 h_00 h	number of mapped objects	UINT8	RW	00 h
1A02 h_01 h	first mapped object	UINT32	RW	0 h
1A02 h_02 h	second mapped object	UINT32	RW	0 h
1A02 h_03 h	third mapped object	UINT32	RW	00 h
1A02 h_04 h	fourth mapped object	UINT32	RW	00 h

- T-PDO4

Index	Comment	Type	Acc.	Default Value
1803 h_00 h	number of entries	UINT8	RO	04 h
1803 h_01 h	COB-ID used by PDO	UINT32	RW	00000481 h
1803 h_02 h	transmission type	UINT8	RW	FF h
1803 h_03 h	inhibit time (100 μ s)	UINT16	RW	64 h
1803 h_05 h	event time (1ms)	UINT16	RW	0A h
1A03 h_00 h	number of mapped objects	UINT8	RW	00 h
1A03 h_01 h	first mapped object	UINT32	RW	0 h
1A03 h_02 h	second mapped object	UINT32	RW	0 h
1A03 h_03 h	third mapped object	UINT32	RW	00 h
1A03 h_04 h	fourth mapped object	UINT32	RW	00 h

If transmit tye is 254 (if PDO content has changed,trigger will be sent by PDO),using the following object can shield parts of PDO changers.Only when the un-shield bit has changed , PDO is occur.If wants shielding any bit, the corresponding bit of object write to 0.

- tpdo_1_transmit_mask

Index	Comment	Type	Acc.	Default Value
2000 h_00 h	number of entries	UINT8	RO	02 h
2000 h_01 h	tpdo_1_transmit_mask_low	UINT32	RW	FFFFFFFF h
2000 h_02 h	tpdo_1_transmit_mask_high	UINT32	RW	FFFFFFFF h

- tpdo_2_transmit_mask

Index	Comment	Type	Acc.	Default Value
2001 h_00 h	number of entries	UINT8	RO	02 h
2001 h_01 h	tpdo_2_transmit_mask_low	UINT32	RW	FFFFFFFF h
2001 h_02 h	tpdo_2_transmit_mask_high	UINT32	RW	FFFFFFFF h

- tpdo_3_transmit_mask

Index	Comment	Type	Acc.	Default Value
2002 h_00 h	number of entries	UINT8	RO	02 h
2002 h_01 h	tpdo_1_transmit_mask_low	UINT32	RW	FFFFFFFF h
2002 h_02 h	tpdo_1_transmit_mask_high	UINT32	RW	FFFFFFFF h

- tpdo_4_transmit_mask

Index	Comment	Type	Acc.	Default Value
2003 h_00 h	number of entries	UINT8	RO	02 h
2003 h_01 h	tpdo_2_transmit_mask_low	UINT32	RW	FFFFFFFF h
2003 h_02 h	tpdo_2_transmit_mask_high	UINT32	RW	FFFFFFFF h

- R-PDO1

Index	Comment	Type	Acc.	Default Value
1400 h_00 h	number of entries	UINT8	RO	02 h
1400 h_01 h	COB-ID used by PDO	UINT32	RW	00000201 h
1400 h_02 h	transmission type	UINT8	RW	FF h
1600 h_00 h	number of mapped objects	UINT8	RW	02 h
1600 h_01 h	first mapped object	UINT32	RW	60400010 h
1600 h_02 h	second mapped object	UINT32	RW	60FF0020 h
1600 h_03 h	third mapped object	UINT32	RW	00 h
1600 h_04 h	fourth mapped object	UINT32	RW	00 h

- R-PDO2

Index	Comment	Type	Acc.	Default Value
1401 h_00 h	number of entries	UINT8	RO	02 h
1401 h_01 h	COB-ID used by PDO	UINT32	RW	00000301 h

Index	Comment	Type	Acc.	Default Value
1401 h_02 h	transmission type	UINT8	RW	FF h
1601 h_00 h	number of mapped objects	UINT8	RW	02 h
1601 h_01 h	first mapped object	UINT32	RW	60FF0020 h
1601 h_02 h	second mapped object	UINT32	RW	60600010 h
1601 h_03 h	third mapped object	UINT32	RW	00 h
1601 h_04 h	fourth mapped object	UINT32	RW	00 h

- R-PDO3

Index	Comment	Type	Acc.	Default Value
1402 h_00 h	number of entries	UINT8	RO	02 h
1402 h_01 h	COB-ID used by PDO	UINT32	RW	00000401 h
1402 h_02 h	transmission type	UINT8	RW	FF h
1602 h_00 h	number of mapped objects	UINT8	RW	00 h
1602 h_01 h	first mapped object	UINT32	RW	0 h
1602 h_02 h	second mapped object	UINT32	RW	0 h
1602 h_03 h	third mapped object	UINT32	RW	00 h
1602 h_04 h	fourth mapped object	UINT32	RW	00 h

- R-PDO4

Index	Comment	Type	Acc.	Default Value
1403 h_00 h	number of entries	UINT8	RO	02 h
1403 h_01 h	COB-ID used by PDO	UINT32	RW	00000501 h
1403 h_02 h	transmission type	UINT8	RW	FF h
1603 h_00 h	number of mapped objects	UINT8	RW	00 h
1603 h_01 h	first mapped object	UINT32	RW	0 h
1603 h_02 h	second mapped object	UINT32	RW	0 h
1603 h_03 h	third mapped object	UINT32	RW	00 h
1603 h_04 h	fourth mapped object	UINT32	RW	00 h

6.2.4 SYNC Message

Synchronization object is used for controlling data synchronize transmit. For example: starting synchronously several axes. The transmission of synchronous message is based on Producer-Customer model. All the nodes of synchronous PDO can receive (at the same time) the message as customer and synchronize other node.

CANopen suggests a COB-ID with highest priority to ensure that synchronized signal could be transmitted properly. Without transferring data, SYNC message could be as short as possible.

The identifier the servo controller receives SYNC messages are fixed to 080h. The identifier can be read via the object **cob_id_sync**.

Index	1005 _h
Name	cob_id_sync
Object Code	VAR
Data Type	UINT32
Access	RW
PDO Mapping	NO
Units	-
Value Range	80000080 _h , 00000080 _h
Default Value	00000080 _h

6.2.5 Emergency Message

When an alarm occurs to drive, CANopen will initiate an Emergency message to inform the current drive type and error code to clients. Error code displayed on panel can be read on low byte of 603Fh object.

The structure of Emergency message:

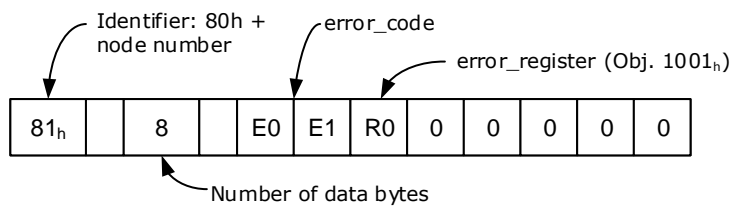

Alarm Codes

error_code (Hex)	Description
2310	Over current
3100	Instantaneous power failure
3110	Over voltage
3120	Under voltage
5080	RAM exception
5210	AD sampling error
5420	Regenerative resistor error
5421	Regenerative resistor exception
5581	Parameter checksum exception
5582	electric gear error
5583	Motor type or drive type error
6100	Illegal error code
6120	PDO mapping error
6300	CAN communication error(Address or communication baud rate error)
7303	serial encoder error

error_code (Hex)	Description
7305	Incremental encoder error
7380	Resolver error
8100	CAN communication exception
8110	CAN bus overflow
8120	PASSIVE CAN bus turn to PASSIVE
8130	Heartbeat error
8140	CAN BUS OFF
8200	Length of CAN messages error
8210	Length of receiving PDO error
8311	Overload alarm
8480	Over speed alarm
8681	Forward run prohibited POT
8682	Reverse run prohibited NOT

Relevant Parameters

Index	1003 _h
Name	pre_defined_error_field
Object Code	ARRAY
No. of Elements	4
Data Type	UINT32

Sub-Index	01 _h
Description	standard_error_field_0
Access	RO
PDO Mapping	NO
Units	–
Value Range	–
Default Value	–

Sub-Index	02 _h
Description	standard_error_field_1
Access	RO
PDO Mapping	NO
Units	–

Sub-Index	02 _h
Value Range	–
Default Value	–

Sub-Index	03 _h
Description	standard_error_field_2
Access	RO
PDO Mapping	NO
Units	–
Value Range	–
Default Value	–

Sub-Index	04 _h
Description	standard_error_field_3
Access	RO
PDO Mapping	NO
Units	–
Value Range	–
Default Value	–

6.2.6 HEARTBEAT Message

Structure

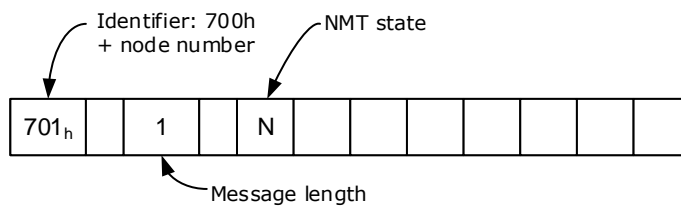

Relevant Parameter

Index	1017 _h
Name	producer_heartbeat_time
Object Code	VAR
Data Type	UINT16
Access	RW
PDO Mapping	NO

Index	1017 _h
Units	ms
Value Range	0 - 65535
Default Value	1000

6.2.7 Network management (NMT service)

Structure

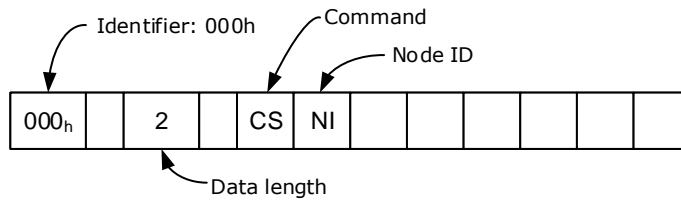

NMT-State machine

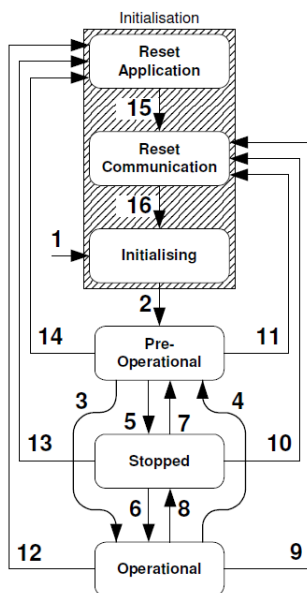

CS	Meaning	Transition	Target state
01 _h	Start Remote Node	3,6	Operational
02 _h	Stop Remote Node	5,8	Stopped
80 _h	Enter Pre-Operational	4,7	Pre-Operational
81 _h	Reset Application	12,13,14	Reset Application
82 _h	Reset Communication	9,10,11	Reset Communication

Name	Meaning	SDO	PDO	NMT
Reset Application	No communication. All CAN objects are set to their reset values (application parameter set).	-	-	-

Name	Meaning	SDO	PDO	NMT
Reset Communication	No communication. The CAN controller will be re-initialised.	-	-	-
Initialising	State after Hardware Reset. Reset of the CAN node, sending of the Bootup message.	-	-	-
Pre-Operational	Communication via SDOs possible. PDOs inactive (No sending/receiving)	×	-	×
Operational	Communication via SDOs possible. PDOs active (sending/receiving)	×	×	×
Stopped	No communication except heartbeat + NMT	-	-	×

6.3 Conversion Factors (Factor Group)

Servo controllers will be used in a huge number of applications: As direct drive, with gear or for linear drives. To allow an easy parameterization for all kinds of applications, the servo controller can be parameterized in such a way that all values like the demand velocity refer to the driven side of the plant. The necessary calculation is done by the servo controller.

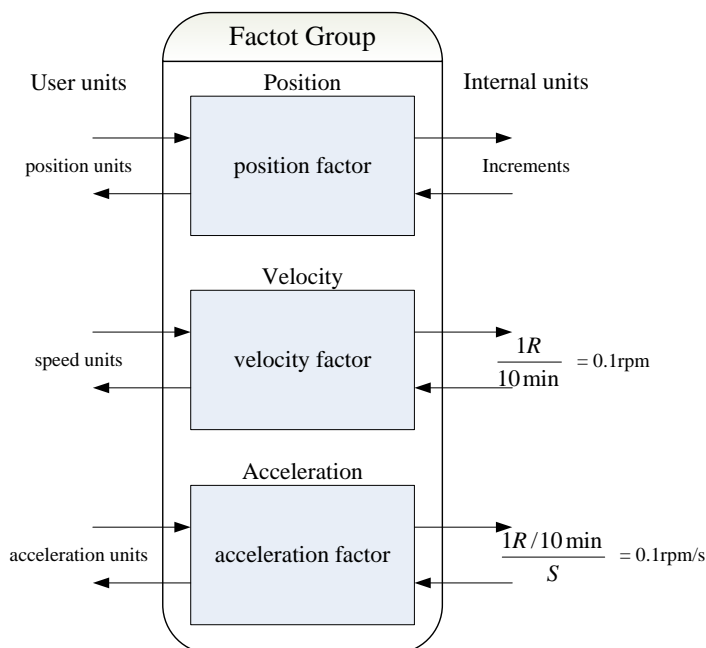

The default setting of the Factor Group is as follows:

Object	Name	Unit	Description
Length	position units	Increments	Increments per revolution *
Velocity	speed units	1R /10min	0.1rpm
Acceleration	Acceleration units	1R/10min/s	0.1rpm/s
Jerk	jerk units	pulse/(s*100 μ s*100 μ s)	Range:1-20, more smaller,more smooth

* : Common incremental encoder: 10000P/R
 Resolver: 65536P/R
 17 bit incremental encoder: 131072P/R

17 bit absolute encoder: 131072P/R
 20 bit absolute encoder: 1048576P/R

6.3.1 Relevant parameters

Index	Object	Name	Type	Attr.
6093 _h	ARRAY	position factor	UINT32	RW
6094 _h	ARRAY	velocity factor	UINT32	RW
6097 _h	ARRAY	acceleration factor	UINT32	RW

6.3.2 Position factor

The object **position factor** converts all values of length of the application from **Position units** into the internal unit **increments** (*encoder resolution* equals 1 Revolution). It consists of numerator and divisor:

Index	6093 _h
Name	position factor
Object Code	ARRAY
No. of Elements	2
Data Type	UINT32

Sub-Index	01 _h
Description	numerator
Access	RW
PDO Mapping	YES
Units	–
Value Range	–
Default Value	When power on, this value will be initiated to parameter Pn201

Sub-Index	02 _h
Description	division
Access	RW
PDO Mapping	YES
Units	–
Value Range	–
Default Value	When power on, this value will be initiated to parameter Pn202

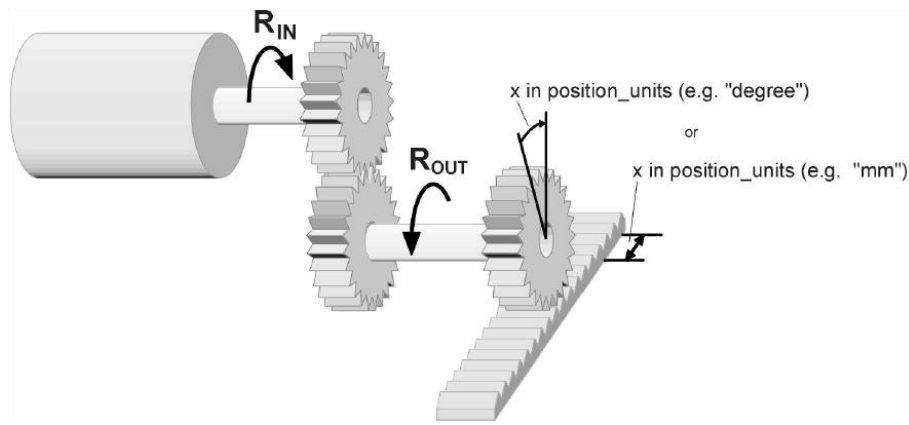

To calculate the **position factor** the following values are necessary:

- **gear_ratio**
Ratio between revolutions on the driving side (R_{IN}) and revolutions on the driven side (R_{OUT}).
- **feed_constant**
Ratio between revolutions on the driven side (R_{OUT}) and equivalent motion in **position_units** (e.g. 1 rev = 360°)

The calculation of the **position_factor** is done with the following equation:

$$\text{position factor} = \frac{\text{numerator}}{\text{division}} = \frac{\text{gear_ratio} * \text{encoder_resolution}}{\text{feed_constant}}$$

Encoder type	Encoder_resolution(Unit: Inc)
Incremental encoder	10000
Resolver	65535
17-bit encoder	131072
20-bit encoder	1048576

6.3.3 Velocity factor

The object **velocity factor** converts all speed values of the application from **speed_units** into the internal unit **revolutions 0.1rpm**. It consists of numerator and divisor

Index	6094 _h
Name	velocity factor
Object Code	ARRAY
No. of Elements	2
Data Type	UINT32

Sub-Index	01 _h
Description	numerator
Access	RW
PDO Mapping	YES
Units	–
Value Range	–

Sub-Index	01 h
Default Value	1

Sub-Index	02 h
Description	division
Access	RW
PDO Mapping	YES
Units	–
Value Range	–
Default Value	1

In principle the calculation of the **velocity factor** is composed of two parts: A conversion factor from internal units of length into **position_units** and a conversion factor from internal time units into user defined time units (e.g. from seconds to minutes). The first part equals the calculation of the **position_factor**. For the second part another factor is necessary for the calculation:

- **time_factor_v**
Ratio between internal and user defined time units. (z.B. **1 min = 1/10 10 min**)
- **gear_ratio**
Ratio between revolutions on the driving side (RIN) and revolutions on the driven side (ROUT).
- **feed_constant**
Ratio between revolutions on the driven side (ROUT) and equivalent motion in position_units (e.g. 1 R = 360°)

The calculation of the velocity factor is done with the following equation:

$$\text{velocity factor} = \frac{\text{numerator}}{\text{division}} = \frac{\text{gear_ratio} * \text{time_factor_v}}{\text{feed_constant}}$$

6.3.4 Acceleration factor

The object **acceleration_factor** converts all acceleration values of the application from **acceleration_units** into the internal unit (0.1rpm) . It consists of numerator and divisor:

Index	6097 h
Name	acceleration factor
Object Code	ARRAY
No. of Elements	2
Data Type	UINT32

Sub-Index	01 h
Description	numerator
Access	RW
PDO Mapping	YES
Units	–
Value Range	–

Sub-Index	01 _h
Default Value	1

Sub-Index	02 _h
Description	division
Access	RW
PDO Mapping	YES
Units	–
Value Range	–
Default Value	1

The calculation of the **acceleration_factor** is also composed of two parts: A conversion factor from internal units of length into **position_units** and a conversion factor from internal time units squared into user defined time units squared (e.g. from seconds² to minutes²). The first part equals the calculation of the **position_factor**. For the second part another factor is necessary for the calculation.

- **time_factor_a**
Ratio between internal time units squared and user defined time units squared
(z.B.: 1min² = 1min*min = 60s*1min =60/10 10min/s)
- **gear_ratio**
Ratio between revolutions on the driving side (RIN) and revolutions on the driven side (ROUT).
- **feed_constant**
Ratio between revolutions on the driven side (ROUT) and equivalent motion in position_units (e.g. 1 R = 360°)

The calculation of the **acceleration_factor** is done with the following equation:

$$\text{acceleration factor} = \frac{\text{numerator}}{\text{division}} = \frac{\text{gear_ratio} * \text{time_factor_v}}{\text{feed_constant}}$$

6.4 Position Control Function

This chapter describes all parameters which are required for the position controller. The desired position value (**position_demand_value**) of the trajectory generator is the input of the position controller. Besides this the actual position value (**position_actual_value**) is supplied by the angle encoder (resolver, incremental encoder, etc.). The behaviour of the position controller can be influenced by parameters.

It is possible to limit the output quantity (**control_effort**) in order to keep the position control system stable. The output quantity is supplied to the speed controller as desired speed value. In the **Factor Group** all input and output quantities are converted from the application-specific units to the respective internal units of the controller

The following subfunctions are defined in this chapter:

6.4.1 Following error

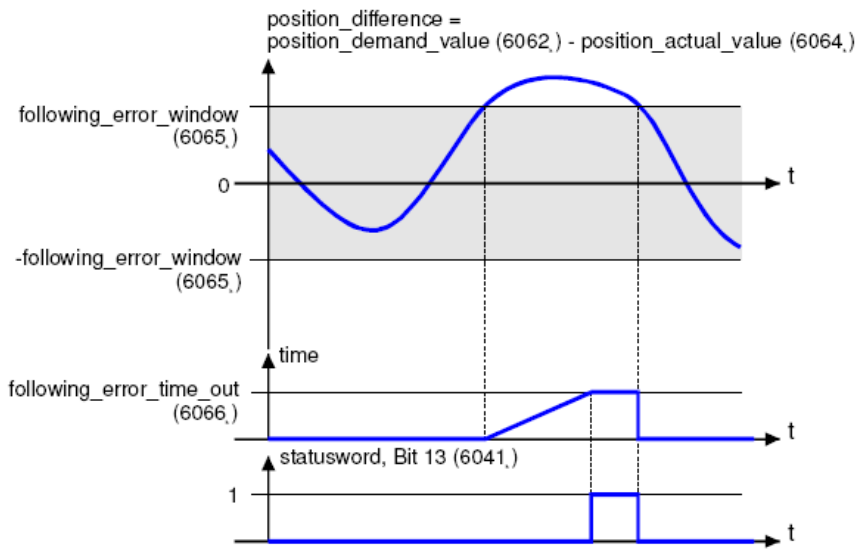

The deviation of the actual position value (**position_actual_value**) from the desired position value (**position_demand_value**) is named trailing error. If for a certain period of time this trailing error is bigger than specified in the trailing error window (**following_error_window**) bit 13 (**following_error**) of the object **statusword** will be set to 1.

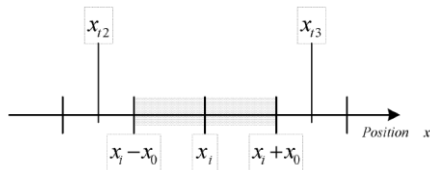

The permissible time can be defined via the object **following_error_time_out**. Figure above shows how the window function is defined for the message "following error". The range between xi-x0 and xi+x0 is defined symmetrically around the desired position (**position_demand_value**) xi. For example the positions xt2 and xt3 are outside this window (**following_error_window**). If the drive leaves this window and does not return to the window within the time defined in the object **following_error_time_out** then bit 13 (**following_error**) in the **statusword** will be set to 1.

6.4.2 Position Reached

This function offers the chance to define a position window around the target position (**target_position**). If the actual position of the drive is within this range for a certain period of time – the **position_window_time** – bit 10 (**target_reached**) will be set to 1 in the statusword.

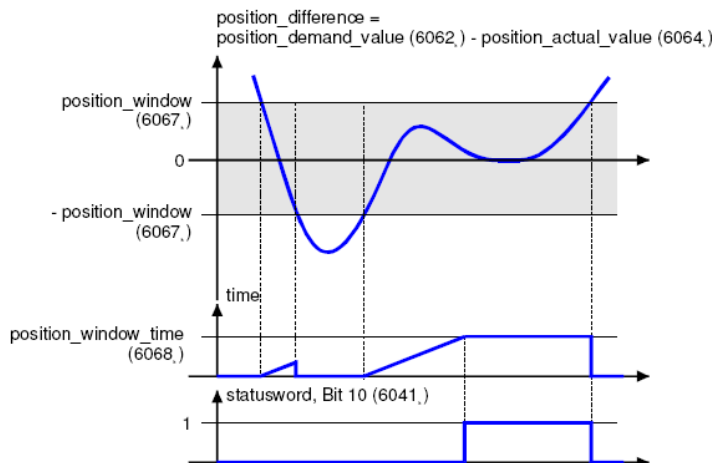
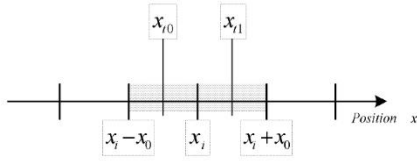

Figure below shows how the window function is defined for the message "position reached". The position range between $x_i - x_0$ and $x_i + x_0$ is defined symmetrically around the target position (**target_position**) x_i . For example the positions x_{t0} and x_{t1} are inside this position window (**position_window**). If the drive is within this window a timer is started. If this timer reaches the time defined in the object **position_window_time** and the drive uninterruptedly was within the valid range between $x_i - x_0$ and $x_i + x_0$, bit 10 (**target_reached**) will be set in the **statusword**. As far as the drive leaves the permissible range, bit 10 is cleared and the timer is set to zero.



6.4.3 Relevant Parameters

Index	Object	Name	Type	Attr.
6062 h	VAR	position_demand_value	INT32	RO
6063 h	VAR	position_actual_value*	INT32	RO
6064 h	VAR	position_actual_value	INT32	RO
6065 h	VAR	following_error_window	UINT32	RW
6066 h	VAR	following_error_time_out	UINT16	RW
6067 h	VAR	position_window	UINT32	RW
6068 h	VAR	position_time	UINT16	RW
60FA h	VAR	control_effort	INT32	RO

Index	6062 h
Name	position_demand_value
Object Code	VAR
Data Type	INT32
Access	RO
PDO Mapping	YES
Units	position units
Value Range	-
Default Value	-

Index	6064 h
Name	position_actual_value
Object Code	VAR
Data Type	INT32
Access	RO
PDO Mapping	YES

Index	6064 h
Units	position units
Value Range	–
Default Value	–

Index	6065 h
Name	following_error_window
Object Code	VAR
Data Type	UINT32
Access	RW
PDO Mapping	YES
Units	position units
Value Range	0 – 7FFFFFFF h
Default Value	30000

Index	6066 h
Name	following_error_time_out
Object Code	VAR
Data Type	UINT16
Access	RW
PDO Mapping	YES
Units	ms
Value Range	0 – 65535
Default Value	200

Index	60FA h
Name	control_effort
Object Code	VAR
Data Type	INT32
Access	RO
PDO Mapping	YES
Units	speed units
Value Range	–
Default Value	–

Index	6067 _h
Name	position_window
Object Code	VAR
Data Type	UINT32
Access	RW
PDO Mapping	YES
Units	position units
Value Range	–
Default Value	10

Index	6068 _h
Name	position_time
Object Code	VAR
Data Type	UINT16
Access	RW
PDO Mapping	YES
Units	ms
Value Range	0 – 65535
Default Value	50

6.5 State machine

Using CANopen the complete control of the servo is done by two objects. Via the **controlword** the host is able to control the servo, as the status of the servo can be read out of the **statusword**. The following items will be used in this chapter:

Term	Description
State	The servo controller is in different states dependent on for instance if the power stage is alive or if an error has occurred. States defined under CANopen will be explained in this chapter.
State Transition	Just as the states it is defined as well how to move from one state to another (e.g. to reset an error). These state transitions will be either executed by the host by setting bits in the controlword or by the servo controller itself, if an error occurs for instance.
Command	To initiate a state transition defined bit combinations have to be set in the controlword . Such bit combination are called command. Example: Enable Operation .
State diagram	All the states and all state transitions together form the so called state diagram: A survey of all states and the possible transitions between two states.

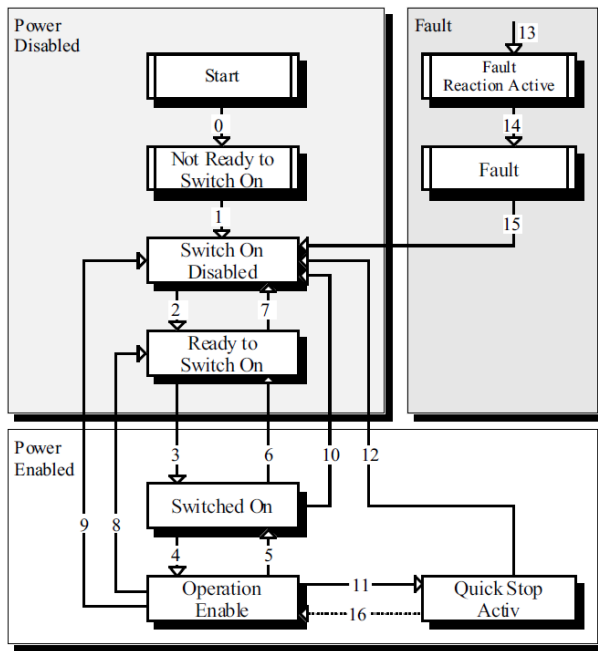

The state diagram can be divided into three main parts: "Power Disabled" means the power stage is switched off and "Power Enabled" the power stage is active. The area "Fault" contains all states necessary to handle errors of the controller. The most important states have been highlighted in the Figure: After switching on the servo controller initializes itself and reaches the state **SWITCH_ON_DISABLED** after all. In this state CAN communication is possible and the servo controller can be parameterized (e.g. the mode of operation can be set to "velocity control"). The power stage remains switched off and the motor shaft is freely rotatable. Through the state transitions 2, 3 and 4 – principally like the controller enable under CANopen - the state **OPERATION_ENABLE** will be reached. In this state the power stage is live and the servo controller controls the motor according to the parameterized mode of operation. Therefore previously ensure that the servo controller has been parameterized correctly and the according demand value is zero. The state transition 9 complies with disabling the power stage, i.e. the motor is freely rotatable.

Status	Description
Not Ready to Switch On	The servo controller executes its self-test. The CAN communication is not working
Switch On Disabled	The self-test has been completed. The CAN communication is activated..
Ready to Switch On	Servo driver is waiting for the state of Switch and servo motor is not at power stage
Switched On	The power stage is alive.
Operation Enable	The motor is under voltage and is controlled according to operational mode
Quick Stop Active	Servo driver will be stopped through its fixed way,
Fault Reaction Active	Servo driver tests error and will be stopped through its fixed way, with motor's power stage alive
Fault	An error has occurred. The power stage has been switched off.

6.6 Relevant Parameters of Device Control

Index	Object	Name	Type	Attr.
6040 _h	VAR	controlword	UINT16	RW

Index	Object	Name	Type	Attr.
6041 _h	VAR	statusword	UINT16	RO
605A _h	VAR	quick_stop_option_code	INT16	RW
605B _h	VAR	shutdown_option_code	INT16	RW
605C _h	VAR	disabled_operation_option_code	INT16	RW
605D _h	VAR	halt_option_code	INT16	RW
605E _h	VAR	fault_reaction_option_code	INT16	RW

6.6.1 Controlword

Index	6040 _h
Name	controlword
Object Code	VAR
Data Type	UINT16
Access	RW
PDO Mapping	YES
Units	--
Value Range	--
Default Value	0

Controlword bit description is as below:

15	11	10	9	8	7	6	4	3	2	1	0
Manufacturer specific	Reserved	halt	Fault reset	Operation mode specific	Enable operation	Quick stop	Enable voltage	Switch on			

Bit0 ~ 3 and Bit7

Transmit of status machine is triggered by 5 bits coordinated control code as below

Command	Bit of the controlword					
	Fault reset	Enable operation	Quick stop	Enable voltage	Switch on	Transitions
Shutdown	0	×	1	1	0	2,6,8
Switch on	0	0	1	1	1	3*
Switch on	0	1	1	1	1	3**
Disable voltage	0	×	×	0	×	7,9,10,12
Quick stop	0	×	0	1	×	7,9,10,11
Disable operation	0	0	1	1	1	5
Enable operation	0	1	1	1	1	4,16

Command	Bit of the controlword					
	Fault reset	Enable operation	Quick stop	Enable voltage	Switch on	Transitions
Fault reset		×	×	×	×	15

NOTE: X means this bit could be ignored.

Bit4, 5, 6, 8

The definition of this 4 bit is different in different control mode.

Bit	Control Mode		
	profile position mode	profile velocity mode	homing mode
4	Newsetpoint	Reserved	Start homingoperation
5	Changeset immediately	Reserved	Reserved
6	abs/rel	Reserved	Reserved
8	Halt	Halt	Halt

Other bits

All reserved.

6.6.2 Statusword

Index	6041 H
Name	Statusword
Object Code	VAR
Data Type	UINT16
Access	RO
PDO Mapping	YES
Units	–
Value Range	–
Default Value	–

Explanation of statusword bit is as below:

Bit	Description
0	Ready to switch on
1	Switched on
2	Operation enabled
3	Fault
4	Voltage enabled
5	Quick stop

Bit	Description
6	Switch on disabled
7	Warning
8	Reserved
9	Remote
10	Target reached
11	Internal limit active
12~13	Operation mode specific
14~15	Reserved

Bit0 ~ 3, Bit5, and Bit6

The combination of this bit indicates the status of drives.

Value (binary)	State
xxxx xxxx x0xx 0000	Not ready to switch on
xxxx xxxx x1xx 0000	Switch on disabled
xxxx xxxx x01x 0001	Ready to switch on
xxxx xxxx x01x 0011	Switched on
xxxx xxxx x01x 0111	Operation enabled
xxxx xxxx x00x 0111	Quick stop active
xxxx xxxx x0xx 1111	Fault reaction active
xxxx xxxx x0xx 1000	Fault

Bit4: Voltage enabled

Main power is on when this bit is 1.

Bit5: Quick stop

Driver will follow setting (605A_n: quick_stop_option_code) to halt when this bit is 0.

Bit7: Warning

Driver detects alarm when this bit is 1.

Bit9: Warning

Servo can deal with Controlword when this bit is 1 and CANOPEN is enabled.

Bit10: Target reached

In different control modes the meaning of this bit is different.

- In profile position mode, when set position is reached, this bit is set. When Halt is booted, speed is reduced to 0 and this bit will be set. When new position is set, this bit will be cleared.

- In profile Velocity Mode, when the speed reaches the targeted speed, this bit will be set. When Halt is booted and speed is reduced to 0, this bit is set.

Bit11: Internal limit active

When this bit is 1, it indicates that internal torque has surpassed the set value, or reached the max. forward/reverse run. It can be confirmed by reading object 60FDh (digital inputs).

Bit12, 13

These 2 bits mean different in different control mode.

Bit	Control mode		
	profile position mode	profile velocity mode	homing mode
12	Set-point acknowledge	Speed	Homing attained
13	Following error	Max slippage error	Homing error

Other bits

All reserved.

6.6.3 Shutdown_option_code

The object **shutdown_option_code** determines the behaviour if the state transition 8 (from OPERATION ENABLE to READY TO SWITCH ON) will be executed.

Index	605B _h
Name	shutdown_option_code
Object Code	VAR
Data Type	INT16
Access	RW
PDO Mapping	NO
Units	–
Value Range	0,1
Default Value	0

Value	Description
0	Power stage will be switched off. Motor is freely rotatable.
1	Switch off the power stage after the motor stops deceleration.

6.6.4 Disable_operation_option_code

The object **disable_operation_option_code** determines the behaviour if the state transition 5 (from OPERATION ENABLE to SWITCHED ON) will be executed.

Index	605C _h
Name	disable_operation_option_code
Object Code	VAR
Data Type	INT16
Access	RW
PDO Mapping	NO
Units	–
Value Range	0,1
Default Value	0

Value	Description
0	Power stage will be switched off. Motor is freely rotatable.
1	Switch off the power stage after the motor stops deceleration.

6.6.5 Quick_stop_option_code

The object **quick_stop_option_code** determines the behaviour if a **Quick Stop** will be executed.

Index	605A _h
Name	quick_stop_option_code
Object Code	VAR
Data Type	INT16
Access	RW
PDO Mapping	NO
Units	–
Value Range	0,1,2,5,6
Default Value	2

Value	Description
0	Power stage will be switched off. Motor is freely rotatable.
1	Switch off the power stage after the motor stops deceleration.
2	Power stage will be shut down after the motor decelerates to still urgently.
5	QuickStop is alive after the motor decelerates to still.
6	QuickStop is alive after the motor decelerates urgently to still.

6.6.6 Halt_option_code

Halt_option_code determines how to stop when bit.8 (halt) of controlword is set to 1.

Index	605D _h
Name	halt_option_code
Object Code	VAR
Data Type	INT16
Access	RW
PDO Mapping	NO
Units	–
Value Range	1,2
Default Value	0

Value	Description
1	The motor decelerates to still.
2	The motor decelerates urgently to still

6.6.7 Fault_reaction_option_code

When an error is occurred, fault_reation_option_code determines how to stop.

Index	605E _h
Name	fault_reaction_option_code
Object Code	VAR
Data Type	INT16
Access	RW
PDO Mapping	NO
Units	–
Value Range	0
Default Value	0

Value	Description
0	Power stage will be switched off. Motor is freely rotatable.

Chapter 7 CANopen Control Mode

EM3A currently supports 5 control modes in CANopen DSP402:

- HOMING MODE
- PROFILE VELOCITY MODE
- PROFILE TORQUE MODE
- PROFILE POSITION MODE
- INTERPOLATED POSITION MODE

7.1 Relevant Parameter of Control Mode

Index	Object	Name	Type	Attr.
6060 _h	VAR	modes_of_operation	INT8	RW
6061 _h	VAR	modes_of_operation_display	INT8	RO

7.1.1 Modes_of_operation

Drive control mode will be determined by parameters in modes_of_operation.

Index	6060 _h
Name	modes_of_operation
Object Code	VAR
Data Type	INT8
Access	RW
PDO Mapping	YES
Units	–
Value Range	1,3,4,6,7
Default Value	1

Value	Description
1	PROFILE POSITION MODE
3	PROFILE VELOCITY MODE
4	PROFILE TORQUE MODE
6	HOMING MODE
7	INTERPOLATION MODE

7.1.2 Modes_of_operation_display

Drive current control mode could be read from parameters in modes_of_operation_display.

Index	6061 _h
Name	modes_of_operation_display
Object Code	VAR
Data Type	INT8
Access	RO
PDO Mapping	YES
Units	–
Value Range	1,3,4,6,7
Default Value	1

NOTE: The current control mode could be only known from parameters in modes_of_operation_display.

7.2 Homing Mode

ED3M servo drive currently supports multiple homing mode and users could choose the suitable homing mode. For example, if an incremental encoder is applied in servomotor, then homing mode of Zero impulse could be chosen and if serial encoder or resolver is applied in servomotor then Zero impulse homing mode couldn't be selected.

The user can determine the velocity, acceleration, and the kind of homing operation. After the servo controller has found its reference the zero position can be moved to the desired point via the object home_offset (607C_h).

7.2.1 Control Word

15 ~ 9	8	7 ~ 5	4	3 ~ 0
*	Halt	*	home_operation_start	*

*: referred to previous chapters

Name	Value	Description
Homingoperationstart	0	Homing mode inactive
	0 → 1	Start homing mode
	1	Homing mode active
	1 → 0	Interrupt homing mode
Halt	0	Execute the instruction of bit 4
	1	Stop axle with homing acceleration

7.2.2 Status Word

15 ~ 14	13	12	11	10	9 ~ 0
*	homing_error	homing_attained	*	target_reached	*

*: referred to previous chapters

Name	Value	Description
Target reached	0	Halt = 0: Home position not reached Halt = 1: Axle decelerates
	1	Halt = 0: Home position reached Halt = 1: Axle has velocity 0
Homing attained	0	Homing mode not yet completed
	1	Homing mode carried out successfully
Homing error	0	No homing error
	1	Homing error occurred; Homing mode carried out not successfully; The error cause is found by reading the error code

7.2.3 Relevant parameter

Index	Object	Name	Type	Attr.
607C _h	VAR	home_offset	INT32	RW
6098 _h	VAR	homing_method	INT8	RW
6099 _h	ARRAY	homing_speeds	UINT32	RW
609A _h	VAR	homing_acceleration	INT32	RW

home_offset

The object **home_offset** determines the displacement of the zero position to the limit resp. reference switch position.

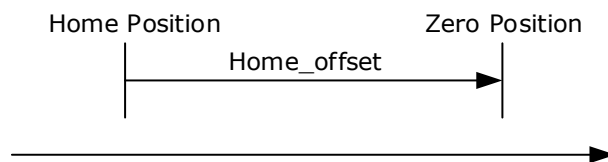

Index	607C _h
Name	home_offset
Object Code	VAR
Data Type	INT32
Access	RW
PDO Mapping	YES
Units	position units
Value Range	-
Default Value	0

homing_method

The negative and positive limit switch, the reference switch and the (periodic) zero impulse of the angle encoder.

Index	6098 _h
Name	homing_method
Object Code	VAR
Data Type	INT8
Access	RW
PDO Mapping	YES
Units	--
Value Range	1-14*, 17-22, 23-30*, 33-35
Default Value	1

NOTE: * means only some servo models support this home mode.

Homing method value description is as following:

Value	Direction	Target	Reference Point	DS402
1	Negative	NOT	Zero impulse	1
2	Positive	POT	Zero impulse	2
3	Negative	Reference switch	Zero impulse	3
4	Positive	Reference switch	Zero impulse	4
5	Negative	Reference switch	Zero impulse	5
6	Positive	Reference switch	Zero impulse	6
7	Positive	Reference switch	Zero impulse	7
8	Positive	Reference switch	Zero impulse	8
9	Positive	Reference switch	Zero impulse	9
10	Positive	Reference switch	Zero impulse	10
11	Negative	Reference switch	Zero impulse	11
12	Negative	Reference switch	Zero impulse	12
13	Negative	Reference switch	Zero impulse	13
14	Negative	Reference switch	Zero impulse	14
17	Negative	NOT	NOT	17
18	Positive	POT	POT	18
19	Negative	Reference switch	Reference switch	19
20	Positive	Reference switch	Reference switch	20
21	Negative	Reference switch	Reference switch	21
22	Positive	Reference switch	Reference switch	22
23	Positive	Reference switch	Reference switch	23
24	Positive	Reference switch	Reference switch	24

Value	Direction	Target	Reference Point	DS402
25	Positive	Reference switch	Reference switch	25
26	Positive	Reference switch	Reference switch	26
27	Negative	Reference switch	Reference switch	27
28	Negative	Reference switch	Reference switch	28
29	Negative	Reference switch	Reference switch	29
30	Negative	Reference switch	Reference switch	30
33	Negative	Current position	Zero impulse	33
34	Positive	Current position	Zero impulse	34
35	–	Current position	Current position	35
-4	Positive	Target torque	Zero impulse	Reserved
-3	Negative	Target torque	Zero impulse	Reserved
-2	Positive	Target torque	Target torque	Reserved
-1	Negative	Target torque	Target torque	Reserved

homing speeds

There are two kinds of speeds required to find reference point, speed during search for switch and speed during search for zero.

Index	6099 h
Name	homing_speeds
Object Code	ARRAY
No. of Elements	2
Data Type	INT32

Sub-Index	01 h
Name	speed_during_search_for_switch
Object Code	VAR
Data Type	INT32
Access	RW
PDO Mapping	YES
Units	speed units
Value Range	–
Default Value	5000

Sub-Index	02 h
Name	speed_during_search_for_zero

Sub-Index	02 _h
Object Code	VAR
Data Type	INT32
Access	RW
PDO Mapping	YES
Units	speed units
Value Range	-
Default Value	100

Pn207 (stopper torque)

It is used for homing method -4, -3, -2, -1. When the drive hits an end so that the torque set in Pn207 is reached for the blocking time set in Pn208, movement in the opposite direction or makes the current position for the origin.

Index	3049 _h
Name	Pn207 (stopper torque)
Object Code	VAR
Data Type	UINT16
Access	RW
PDO Mapping	NO
Units	1% rated torque
Value Range	0-200
Default Value	20

Pn208 (blocking time)

It is used for homing method -4, -3, -2, -1. When the drive hits an end so that the torque set in Pn207 is reached for the blocking time set in Pn208, movement in the opposite direction or makes the current position for the origin.

Index	304A _h
Name	Pn208 (Blocking time)
Object Code	VAR
Data Type	UINT16
Access	RW
PDO Mapping	NO
Units	0.125ms
Value Range	0-10000
Default Value	100

homing_acceleration

The objects **homing_acceleration** determine the acceleration which is used for all acceleration and deceleration operations during the search for reference.

Index	609A _h
Name	homing_acceleration
Object Code	VAR
Data Type	INT32
Access	RW
PDO Mapping	YES
Units	acceleration units
Value Range	–
Default Value	100000

7.2.4 Homing Sequences

Method 1: Using egative limit switch and zero impulse evaluation

A: When homing mode is enabled, If negative limit switch N-OT=0, the drive first moves relatively quick into the negative direction until it reaches the negative limit switch. This is displayed in the diagram by the rising edge. Afterwards the drive slowly returns, and stops until reaches the falling edge.

B: When homing mode is enabled, If negative limit switch N-OT=1, the drive first moves slowly into the positive direction until reaches the falling edge.

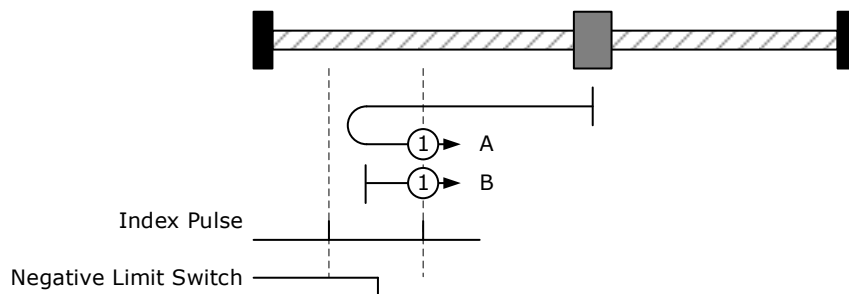

Method 2: Using positive limit switch and zero impulse evaluation

A: When homing mode is enabled, If positive limit switch P-OT=0, the drive first moves relatively quick into the positive direction until it reaches the positive limit switch. This is displayed in the diagram by the rising edge. Afterwards the drive slowly returns, and stops until reaches the falling edge.

B: When homing mode is enabled, If positive limit switch P-OT=1, the drive first moves slowly into the negative direction until reaches the falling edge.

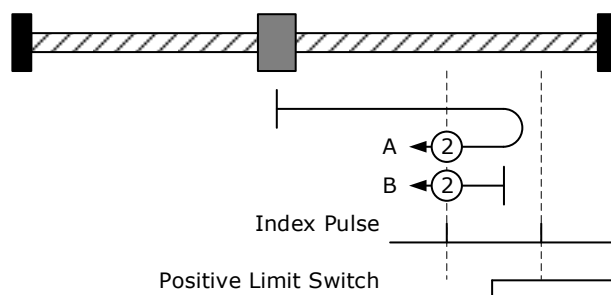

Methods 3 and 4: Using positive reference switch and zero impulse evaluation

- Method 3

A: When homing mode is enabled, If positive reference switch H-S=0, the drive first moves relatively quick into the positive direction until it reaches the positive reference switch. This is displayed in the diagram by the rising edge.

B: When homing mode is enabled, If positive reference switch H-S =1, the drive first moves slowly into the negative direction until reaches the falling edge.

- Method 4

A: When homing mode is enabled, If positive reference switch H-S =0, the drive first moves slowly into the positive direction until reaches the rising edge.

B: When homing mode is enabled, If positive reference switch H-S=1, the drive first moves relatively quick into the negative direction until it reaches the positive reference switch. This is displayed in the diagram by the falling edge. Afterwards the drive slowly returns, and stops until reaches the rising edge.

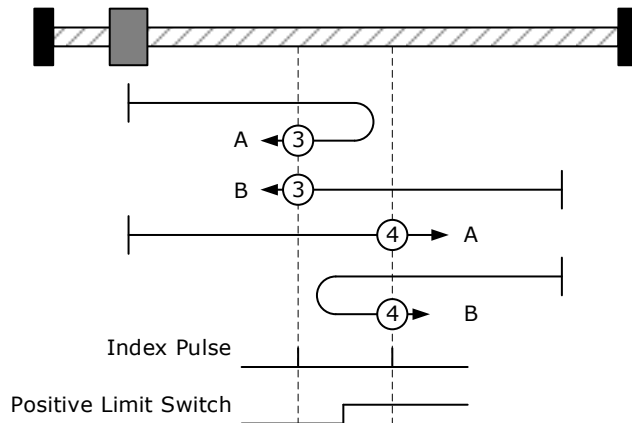

Methods 5 and 6: Using negative reference switch and zero impulse evaluation

- Method 5

A: When homing mode is enabled, If negative reference switch H-S =1, the drive first moves slowly into the positive direction until reaches the zero impulse evaluation. This is displayed in the diagram by the falling edge of H-S.

B: When homing mode is enabled, If negative reference switch H-S=0, the drive first moves relatively quick into the negative direction until it reaches the negative reference switch. This is displayed in the diagram by the rising edge. Afterwards the drive slowly returns, and stops until reaches the zero impulse evaluation. This is displayed in the diagram by the falling edge of H-S.

- Method 6

A: When homing mode is enabled, If negative reference switch H-S=1, the drive first moves relatively quick into the positive direction until it reaches the negative reference switch. This is displayed in the diagram by the falling edge. Afterwards the drive slowly returns, and stops until reaches the zero impulse evaluation. This is displayed in the diagram by the rising edge of H-S.

B: When homing mode is enabled, If negative reference switch H-S =0, the drive first moves slowly into the positive direction, and stops until reaches the zero impulse evaluation. This is displayed in the diagram by the rising edge of H-S.

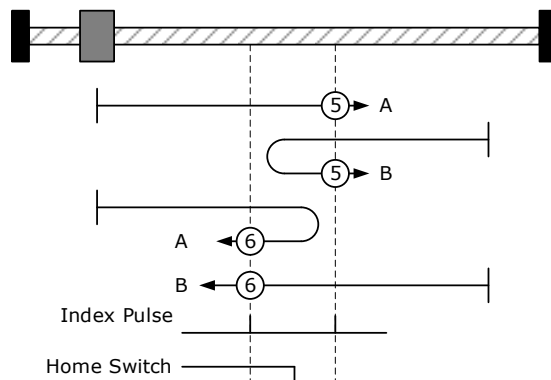

Methods 7 ~ 14 Using reference switch , limit switch and zero impulse evaluation

Methods 7~14 use the reference switch which is only active over parts of the distance.

- Use positive limit switch P-OT.

If this method 7~10 is used the drive first moves relatively quick into the positive direction

- Method 7

A: When homing mode is enabled, If reference switch H-S=0, the drive first moves relatively quick into the positive direction ,not reaches positive limit switch ,until it reaches the reference switch H-S. This is displayed in the diagram by the rising edge. Afterwards the drive slowly returns, and stops until reaches the falling edge.

B: When homing mode is enabled, If reference switch H-S =1, the drive first moves slowly into the negative direction until reaches the falling edge.

C: When homing mode is enabled, If reference switch H-S=0, the drive first moves relatively quick into the positive direction , and reaches positive limit switch .The drive moves quickly into the negative direction.When reachinig the rising edge of H-S ,the drive moves slowly , and moves into the negative direction until reaches the falling edge of H-S.

- Method 8

A: When homing mode is enabled, If reference switch H-S=0, the drive first moves relatively quick into the positive direction ,not reaches positive limit switch , Afterwards the drive moves slowly into positive derection when reaches the rising edge of H-S, and stops until reaches the zero impulse evaluation.

B: When homing mode is enabled, If reference switch H-S =1, the drive first moves slowly into the negative direction until reaches the falling edge of H-S. Then moves slowly into the positive direction, stops until reaches the zero impulse evaluation. This is displayed in the diagram by the H-S rising edge.

C: When homing mode is enabled, If reference switch H-S=0, the drive first moves relatively quick into the positive direction ,reaches positive limit switch ,Afterwards the drive moves quickly into the negative derection,until reaches the rising edge of H-S. The drive slows down, and moves into into the negative derection.Reaches the falling edge of H-S,the drive returns into positive derection,until reaches the zero impulse evaluation.This is displayed in the diagram by the H-S rising edge.

- Method 9

A: When homing mode is enabled, If reference switch H-S=0, the drive first moves relatively quick into the positive direction ,not reaches positive limit switch. Afterwards the drive moves slowly into positive derection when reaches the rising edge of H-S. The drive slows down to stop until reaches the falling edge of H-S.Then drive returns slowly,and stops until reaches the zero impulse evaluation.This is displayed in the diagram by the H-S rising edge.

B: When homing mode is enabled, If reference switch H-S =1, the drive first moves slowly into the postive direction until reaches the falling edge of H-S. Then moves slowly into the negative direction, stops until reaches the zero impulse evaluation. This is displayed in the diagram by the H-S rising edge.

C: When homing mode is enabled, If reference switch H-S=0, the drive first moves relatively quick into the positive direction ,reaches positive limit switch ,Afterwards the drive moves quickly into the negative derection,until reaches the rising edge of H-S. The drive slows down, and moves into into the negative derection, and stops until reaches the zero impulse evaluation.

- Method 10

A: When homing mode is enabled, If reference switch H-S=0, the drive first moves relatively quick into the positive direction, not reaches positive limit switch. Afterwards the drive moves slowly into positive derection when reaches the rising edge of H-S.If reaches the falling edge of H-S,the drive moves slowly into positive derection until reaches the zero impulse evaluation.

B: When homing mode is enabled, If reference switch H-S =1, the drive first moves slowly into the positive direction until reaches the zero impulse evaluation. This is displayed in the diagram by the H-S falling edge.

C: When homing mode is enabled, If reference switch H-S=0, the drive first moves relatively quick into the positive direction ,reaches positive limit switch ,Afterwards the drive moves quickly into the negative derection,until reaches the rising edge of H-S. The drive slows down to stop.Then the drive returns slowly to the positive derection, stops until reaches the zero impulse evaluation. This is displayed in the diagram by the H-S falling edge.

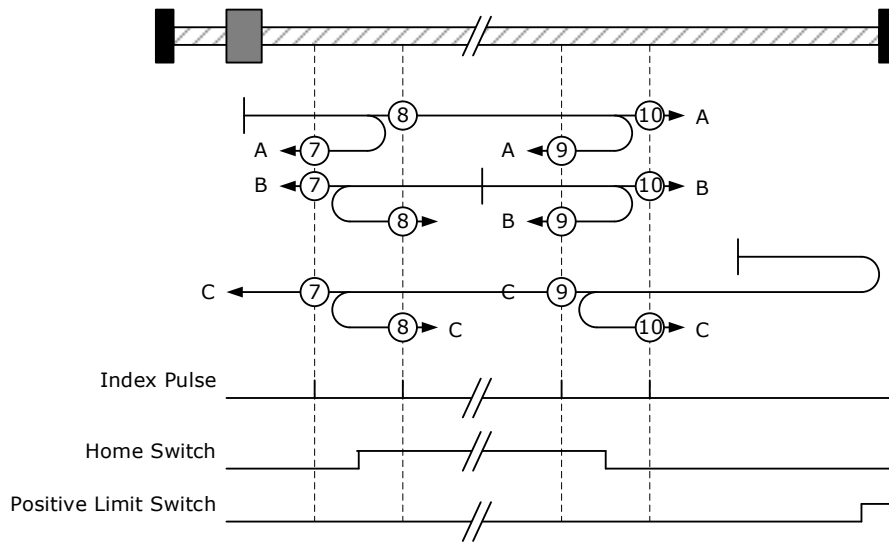

- Use negative limit switch
If this method 11~14 is almost same as method 7~10, the drive first moves relatively quick into the negative direction.

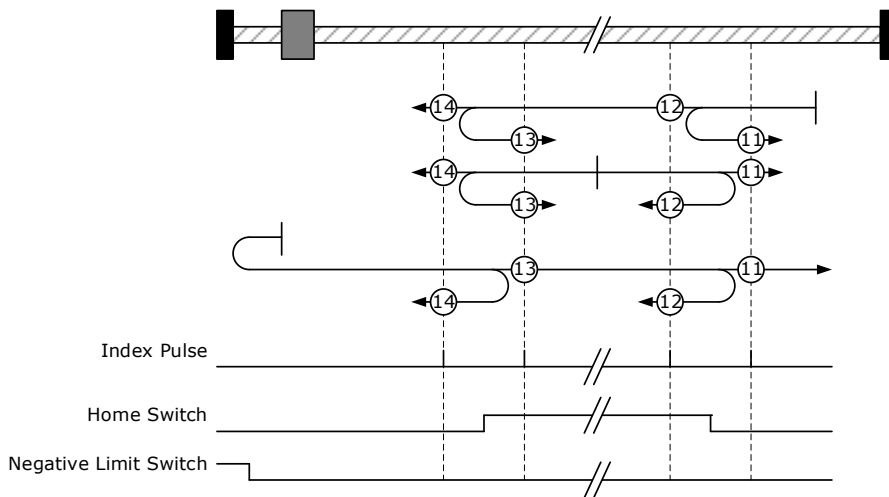

Method 17~20, 23~30: Homing operation to the negative limit switch

If this method is used the drive first moves relatively quick into the negative direction, until it reaches the negative limit switch. This is displayed in the diagram by the rising edge. Afterwards the drive slowly returns and searches for the exact position of the limit switch. The zero position refers to the descending edge from the negative limit switch.

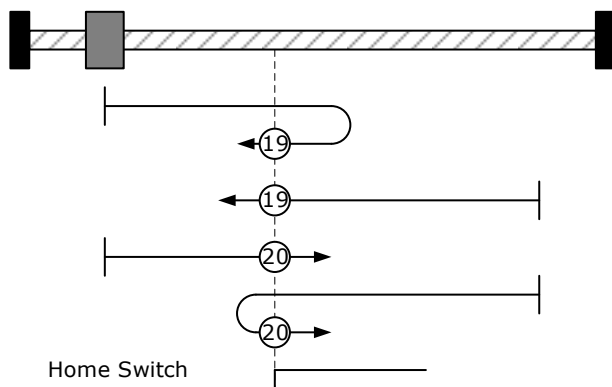

Methods 21, 22 Using reference switch

- Method 21

A: When homing mode is enabled, If reference switch H-S=1, the drive first moves slowly into the positive direction until reaches the falling edge of H-S.

B: When homing mode is enabled, If reference switch H-S=0, the drive first moves relatively quick into the negative direction until it reaches the reference switch. This is displayed in the diagram by the rising edge. Then the drive returns slowly to the positive direction, stops until reaches the falling edge of the H-S.

- Method 22

A: When homing mode is enabled, If reference switch H-S=1, the drive first moves relatively quick into the positive direction until it reaches the reference switch. This is displayed in the diagram by the falling edge. Afterwards the drive slowly returns, and stops until reaches the rising edge of the H-S.

B: When homing mode is enabled, If reference switch H-S=0, the drive first moves slowly into the negative direction until reaches the rising edge of the H-S.

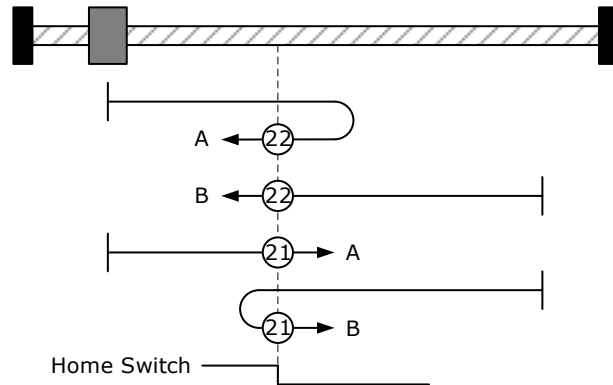

Methods 33, 34 Using zero impulse evaluation

- Method 33: The drive moves slowly into the negative direction, stops until reaches the zero impulse evaluation.

- Method 34: The drive moves slowly into the positive direction, stops until reaches the zero impulse evaluation.

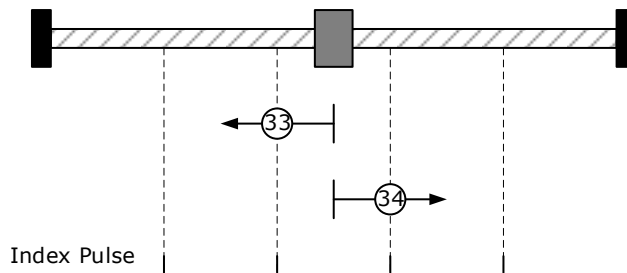

Method 35: Set current position as the homing point

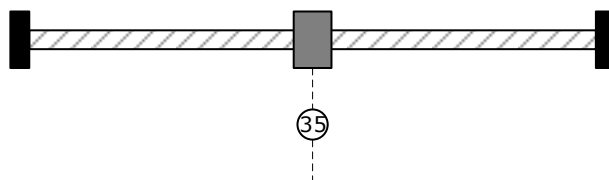

Method -4 Movement in positive direction, hitting an end and reversing to travel, the target homing position is the first C pulse

In this method, the motor moves in positive direction. When it hits an end so that the torque set in Pn207 is reached for the blocking time set in Pn208, movement in the opposite direction, and the target homing position is the first C pulse.

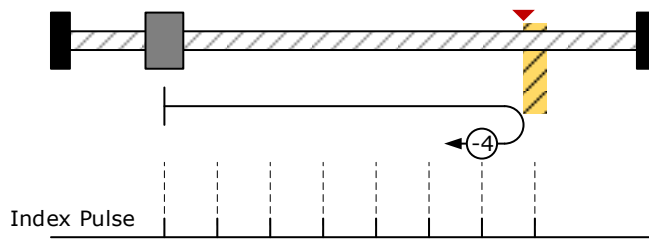

Method -3 Movement in negative direction, hitting an end and reversing to travel, the target homing position is the first C pulse

In this method, the motor moves in negative direction. When it hits an end so that the torque set in Pn207 is reached for the blocking time set in Pn208, movement in the opposite direction, and the target homing position is the first C pulse.

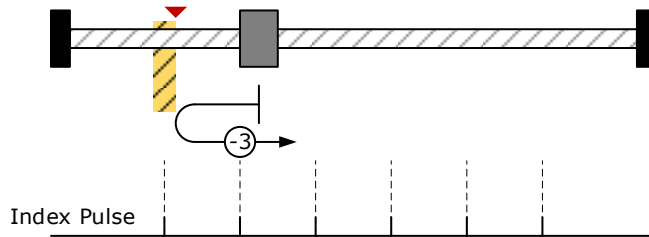

Method -2: Movement in positive direction, hitting an end, makes the current position for the origin.

In this method, the motor moves in positive direction. When the drive hits an end so that the torque set in Pn207 is reached for the blocking time set in Pn208, and makes the current position for the origin.

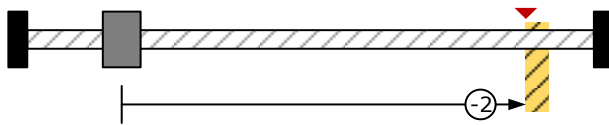

Method -1: Movement in negative direction, hitting an end, makes the current position for the origin.

In this method, the motor moves in negative direction. When the drive hits an end so that the torque set in Pn207 is reached for the blocking time set in Pn208, and makes the current position for the origin.

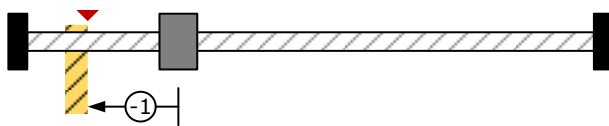

Notes: When starting homing on homing method about input signal, the rotation direction of servo motor is associated with the initial status of the input signal. Changing the initial status by inverse input on set Pn516/Pn517 if it is necessary. When using reference switch homing, I/O should be set as C:HmRef by Pn509/Pn510.

7.3 Profile Velocity Mode

7.3.1 Flow Diagram

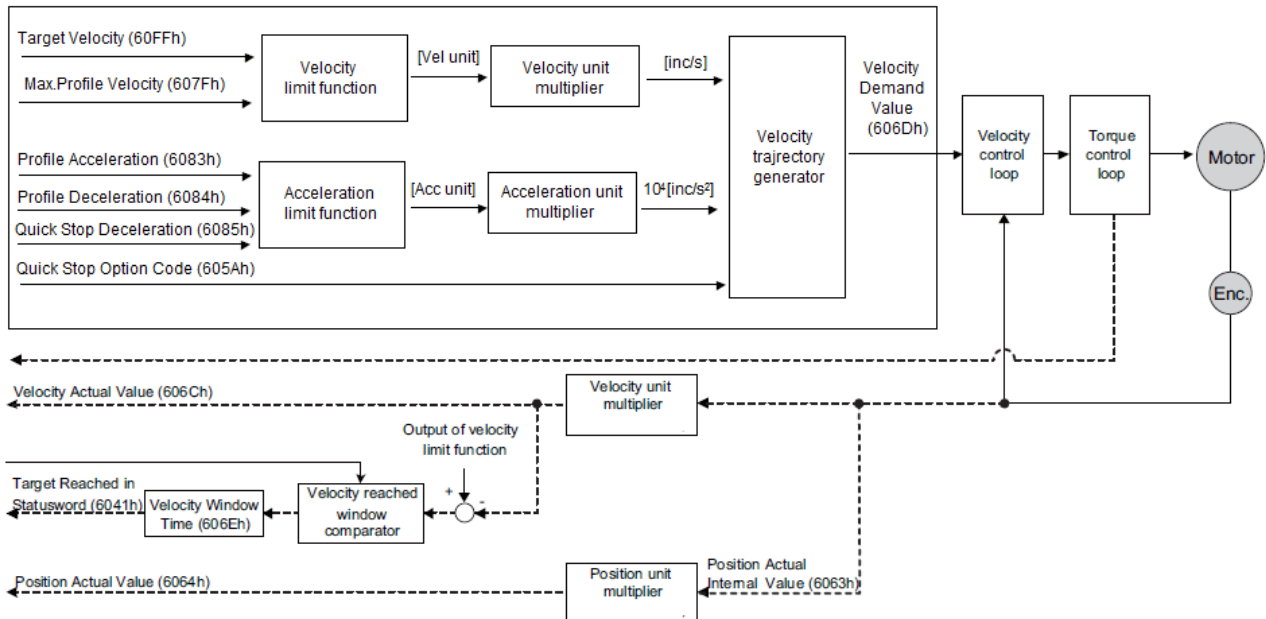

7.3.2 Control word

15 ~ 9	8	7 ~ 4	3 ~ 0
*	Halt	*	*

*: referred to previous chapters

Name	Value	Description
Halt	0	Execute the motion
	1	Stop axle

7.3.3 Status word

15 ~ 14	13	12	11	10	9 ~ 0
*	MaxSlippageError	Speed	*	Target reached	*

*: referred to previous chapters

Name	Value	Description
Target reached	0	Halt = 0: Target velocity not reached Halt = 1: Axle decelerates
	1	Halt = 0: Target velocity reached Halt = 1: Axle has velocity 0
Speed	0	Speed is not equal 0
	1	Speed is equal 0

Name	Value	Description
Max slippage error	0	Maximum slippage not reached
	1	Maximum slippage reached

7.3.4 Relevant Parameters

Index	Object	Name	Type	Attr.
6069 _h	VAR	velocity_sensor_actual_value	INT32	RO
606B _h	VAR	velocity_demand_value	INT32	RO
606C _h	VAR	velocity_actual_value	INT32	RO
606D _h	VAR	velocity_window	UINT16	RW
606E _h	VAR	velocity_window_time	UINT16	RW
606F _h	VAR	velocity_threshold	UINT16	RW
6070 _h	VAR	velocity_threshold_time	UINT16	RW
607F _h	VAR	Max profile velocity	UINT32	RW
60FF _h	VAR	target_velocity	INT32	RW

velocity_sensor_actual_value

The speed encoder is read via the object **velocity_sensor_actual_value**. The value is normalised in internal units. The velocity demand value can be read via this object.

Index	6069 _h
Name	velocity_sensor_actual_value
Object Code	VAR
Data Type	INT32
Access	RW
PDO Mapping	YES
Units	0.1rmps (1R/10min)
Value Range	–
Default Value	–

velocity_demand_value

The velocity demand value can be read via this object. The unit of this object is the unit of user's speed unit. The velocity demand value can be read via this object.

Index	606B _h
Name	velocity_demand_value
Object Code	VAR
Data Type	INT32

Index	606B _h
Access	RO
PDO Mapping	YES
Units	speed units
Value Range	–
Default Value	–

velocity actual value

The actual velocity value can be read via the object **velocity_actual_value**. The velocity demand value can be read via this object.

Index	606C _h
Name	velocity_actual_value
Object Code	VAR
Data Type	INT32
Access	RO
PDO Mapping	YES
Units	speed units
Value Range	–
Default Value	–

velocity window

With the object **velocity_window** a tolerance window for the velocity actual value will be defined for comparing the **velocity_actual_value** (606C_h) with the target velocity (**target_velocity** object **60FFh**). If the difference is smaller than the velocity window (606D_h) for a longer time than specified by the object **velocity_window_time** (606E_h) bit 10 (**target_reached**) will be set in the object **statusword**.

Index	606D _h
Name	velocity_window
Object Code	VAR
Data Type	UINT16
Access	RW
PDO Mapping	YES
Units	speed units
Value Range	–
Default Value	20 R/10min

velocity_window_time

The object **velocity_window_time** serves besides the object **606Dh: velocity_window** to adjust the window comparator.

Index	606E _h
Name	velocity_window_time
Object Code	VAR
Data Type	UINT16
Access	RW
PDO Mapping	YES
Units	ms
Value Range	–
Default Value	0

velocity_threshold

The object **velocity_threshold** determines the velocity underneath the axis is regarded as stationary. As soon as the **velocity_actual_value** exceeds the **velocity_threshold** longer than the **velocity_threshold_time** bit 12 is cleared in the statusword.

Index	606F _h
Name	velocity_threshold
Object Code	VAR
Data Type	UINT16
Access	RW
PDO Mapping	YES
Units	speed units
Value Range	–
Default Value	50

velocity_threshold_time

The object **velocity_threshold** determines the velocity below the axis is regarded as stationary. Its unit is ms. As soon as the **velocity_actual_value** exceeds the **velocity_threshold** longer than the **velocity_threshold_time** bit 12 is cleared in the **statusword**.

Index	6070 _h
Name	velocity_threshold_time
Object Code	VAR
Data Type	UINT16
Access	RW
PDO Mapping	YES

Index	6070 _h
Units	ms
Value Range	–
Default Value	0

Max profile velocity

The object max profile velocity is the speed that the motor can not exceed. Its unit is the unit of customer's speed.

Index	607F _h
Name	Max profile velocity
Object Code	VAR
Data Type	UINT32
Access	RW
PDO Mapping	YES
Units	speed units
Value Range	–
Default Value	0

target_velocity

The object **target_velocity** is the setpoint for the ramp generator.

Index	60FF _h
Name	target_velocity
Object Code	VAR
Data Type	INT32
Access	RW
PDO Mapping	YES
Units	speed units
Value Range	–
Default Value	0

7.4 Profile Torque Mode

7.4.1 Flow Diagram

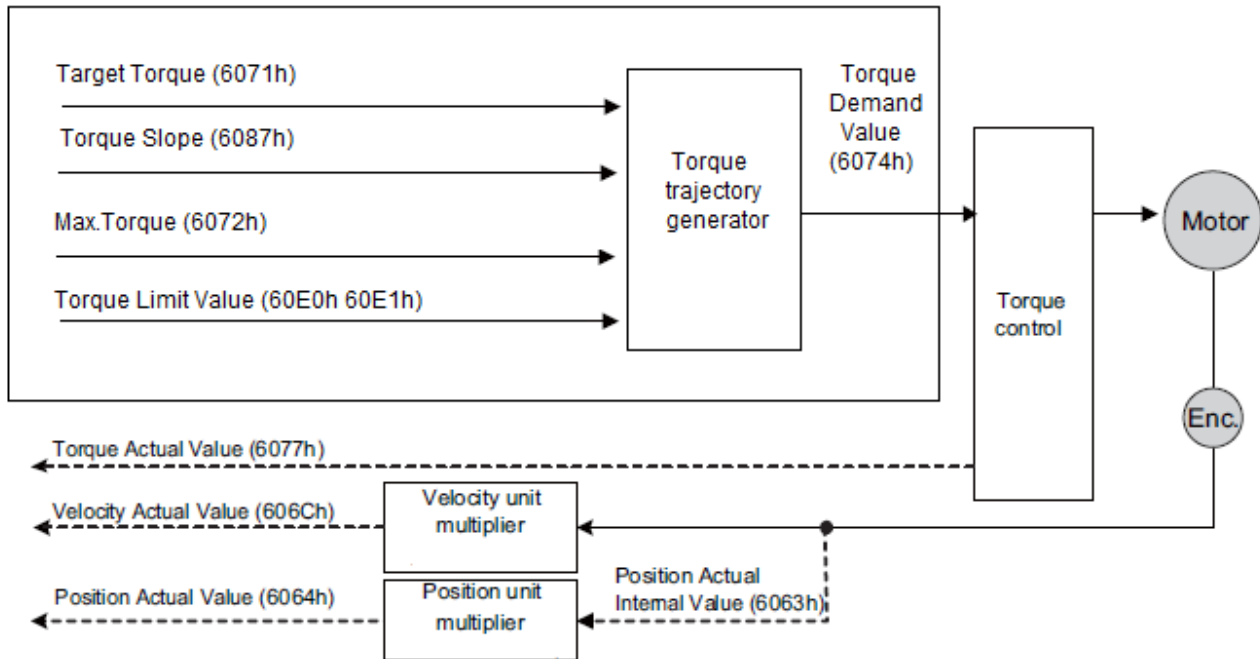

7.4.2 Control Word

15 ~ 9	8	7 ~ 4	3 ~ 0
*	Halt	*	*

*: referred to previous chapters

bit	Value	Definition
8	0	The motion shall be executed 8 or continued
	1	Axis shall be stopped according to the halt option code (605Dh)

7.4.3 Status Word

15 ~ 14	13	12	11	10	9 ~ 0
*	*	*	*	Target reached	*

*: referred to previous chapters

bit	Value	Definition
10	0	Target torque not reached
	1	Target torque reached

7.4.4 Relevant Parameters

Index	Object	Name	Type	Attr.
6071 h	VAR	target_torque	INT16	RW
6072 h	VAR	Max torque	UINT16	RW
6074 h	VAR	torque_demand	INT16	RO
6077 h	VAR	torque_actual_value	INT16	RO
6087 h	VAR	torque_slope	UINT32	RW

target_torque

The torque command can be sent via target_torque. Unit: 0.1% rated torque.

Index	6071 h
Name	target_torque
Object Code	VAR
Data Type	INT16
Access	RW
PDO Mapping	YES
Units	0.1% rated torque
Value Range	-
Default Value	-

Max torque

The object max torque is the torque that the motor can not exceed. Unit: 0.1% rated torque.

Index	6072 h
Name	Max torque
Object Code	VAR
Data Type	UINT16
Access	RW
PDO Mapping	YES
Units	0.1% rated torque
Value Range	--
Default Value	0

torque_demand

The output of the torque command generator. The driver generates the command according to the value of Target_Torque and Torque_Slope.

Index	6074 _h
Name	torque_demand
Object Code	VAR
Data Type	INT16
Access	RO
PDO Mapping	YES
Units	0.1% rated torque
Value Range	–
Default Value	–

torque_actual_value

The torque output can be read via torque_actual_value. Unit: 0.1% rated torque.

Index	6077 _h
Name	torque_actual_value
Object Code	VAR
Data Type	INT16
Access	RO
PDO Mapping	YES
Units	0.1% rated torque
Value Range	–
Default Value	–

torque_slope

The speed of variational torque command can be set via torque_slope. Unit: 0.1% rated torque/S.

Index	6087 _h
Name	torque_slope
Object Code	VAR
Data Type	UINT32
Access	RW
PDO Mapping	YES
Units	0.1% rated torque/S
Value Range	–
Default Value	–

7.5 Profile Position Mode

7.5.1 Flow diagram

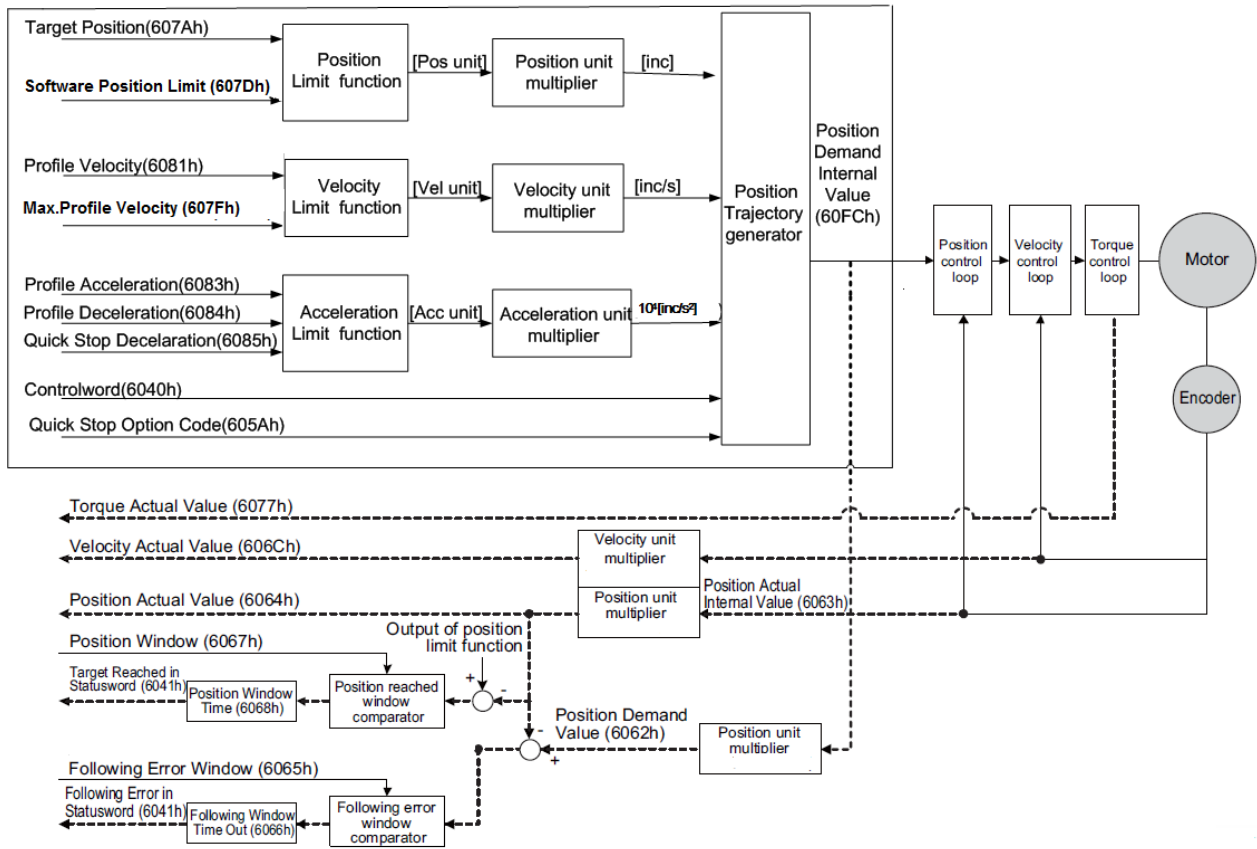

7.5.2 Control Word

15 ~ 9	8	7	6	5	4	3 ~ 0
*	Halt	*	abs / rel	change set immediately	New set-point	*

*: referred to previous chapter

Name	Value	Description
New set-point	0	Does not assume target position
	1	Assume target position
Change set immediately	0	Finish the actual positioning and then start the next positioning
	1	Interrupt the actual positioning and start the next positioning
abs/rel	0	Target position is an absolute value
	1	Target position is a relative value
Halt	0	Execute positioning
	1	Stop axle with profile deceleration (if not supported with profile acceleration)

7.5.3 Status word

15 ~ 14	13	12	11	10	9 ~ 0
*	Following error	Set_point acknowledge	*	Target reached	*

*: referred to previous chapter

Name	Value	Description
Target reached	0	Halt = 0: Target position not reached Halt = 1: Axle decelerates
	1	Halt = 0: Target position reached Halt = 1: Velocity of axle is 0
Set-point acknowledge	0	Trajectory generator has not assumed the positioning values (yet)
	1	Trajectory generator has assumed the positioning values
Following error	0	No following error
	1	Following error

7.5.4 Relevant Parameters

Index	Object	Name	Type	Attr.
607A _h	VAR	target_position	INT32	RW
6081 _h	VAR	profile_velocity	UINT32	RW
6082 _h	VAR	end_velocity	UINT32	RW
6083 _h	VAR	profile_acceleration	UINT32	RW
6084 _h	VAR	profile_deceleration	UINT32	RW
6085 _h	VAR	quick_stop_deceleration	UINT32	RW
6086 _h	VAR	motion_profile_type	INT16	RW
60A4-01 _h	VAR	Profile_jerk1	UINT32	RW

target_position

The object **target_position** determines the destination the servo controller moves to. The target position (**target_position**) is interpreted either as an absolute or relative position. This depends on bit 6 (**relative**) of the object **control word**.

Index	607A _h
Name	target_position
Object Code	VAR
Data Type	INT32
Access	RW
PDO Mapping	YES
Units	position units

Index	607A _h
Value Range	–
Default Value	0

profile_velocity

The object **profile_velocity** specifies the speed that usually is reached during a positioning motion at the end of the acceleration ramp. The object **profile_velocity** is specified in **speed_units**.

Index	6081 _h
Name	profile_velocity
Object Code	VAR
Data Type	UINT32
Access	RW
PDO Mapping	YES
Units	speed units
Value Range	–
Default Value	0

end_velocity

The object **end_velocity** defines the speed at the target position (**target_position**). Usually this object has to be set to zero so that the controller stops when it reaches the target position. For gapless sequences of positionings a value unequal zero can be set.

Index	6082 _h
Name	end_velocity
Object Code	VAR
Data Type	UINT32
Access	RW
PDO Mapping	YES
Units	speed units
Value Range	–
Default Value	0

profile_acceleration

The object **profile_acceleration** determines the maximum acceleration used during a positioning motion. It is specified in user specific acceleration units (**acceleration_units**).

Index	6083 _h
Name	profile_acceleration

Index	6083 _h
Object Code	VAR
Data Type	UINT32
Access	RW
PDO Mapping	YES
Units	acceleration units
Value Range	–
Default Value	100000 R/10min/s

profile deceleration

The object **profile deceleration** specifies the maximum deceleration used during a positioning motion. This object is specified in the same units as the object **profile acceleration**.

Index	6084 _h
Name	profile_deceleration
Object Code	VAR
Data Type	UINT32
Access	RW
PDO Mapping	YES
Units	acceleration units
Value Range	–
Default Value	100000 R/10min/s

quick stop deceleration

The object **quick stop deceleration** determines the deceleration if a Quick Stop will be executed.

Index	6085 _h
Name	quick_stop_deceleration
Object Code	VAR
Data Type	UINT32
Access	RW
PDO Mapping	YES
Units	acceleration units
Value Range	–
Default Value	200000 R/10min/s

motion_profile_type

The object **motion_profile_type** is used to select the kind of speed profile. At present only a linear trapezia profile (set as 0) and a stable S linear jerk profile are available (set as 2).

Index	6086 _h
Name	motion_profile_type
Object Code	VAR
Data Type	INT16
Access	RW
PDO Mapping	YES
Units	-
Value Range	0or2
Default Value	0

profile_jerk1

Profile_jerk1 is used to set the jerk of speed profile. The value is more smaller, the speed changing is more smooth.

Index	60A4 -01 _h
Name	profile_jerk1
Object Code	VAR
Data Type	UINT32
Access	RW
PDO Mapping	YES
Units	jerk units
Value Range	1-20
Default Value	5pulse/(s*100 μ s*100 μ s)

7.5.5 Function description

When the speed profile is trapezia (motion_profile_type=0), two different ways to apply target positions to the servo controller are supported.

Single-Step Set

After reaching the **target_position** the servo controller signals this status to the host by the bit **target_reached** (Bit 10 of **controlword**) and then receives a new setpoint. The servo controller stops at the **target_position** before starting a move to the next setpoint.

When moving to a setpoint, the servo controller signals a new setpoint by the bit **target_reached** (Bit 4 of **controlword**). Then the servo drive will move to the new setpoint.

Multi-Step Set

After reaching the **target_position** the servo controller signals this status to the host by the bit **target_reached** (Bit 10 of **controlword**) and then receives a new setpoint. The servo controller stops at the **target_position** before starting a move to the next setpoint.

These Two methods are controlled by the bit4 and **bit5** in the object **controlword** and **set_point_acknowledge** in the object **statusword**. These bits are in a request-response relationship. So it is possible to prepare one positioning job while another job is still running.

Single-Step Setting Procedure

1. At first set NMT as Operational and control mode parameter (6061h) as 1.
2. At first the positioning data (**target_position: 607A_h** , **profile_velocity**, **end_velocity** and **profile_acceleration**) are transferred to the servo controller.
3. The host can start the positioning motion by setting the bit4 (**new_set_point**) in the **controlword** as 1, bit5 (**change_set_immediately**) as 1 and bit6 as absolute or referential type according to target position type (absolute or referential).
4. This will be acknowledged by the servo controller by setting the bit **set_point_acknowledge** in the **statusword** when the positioning data has been copied into the internal buffer. Motion could be started now.
5. When the target is reached, drive will be acknowledged by bit 10 (**target_reached**) in status word. And then it will run gapless according to program or accept a new target position.

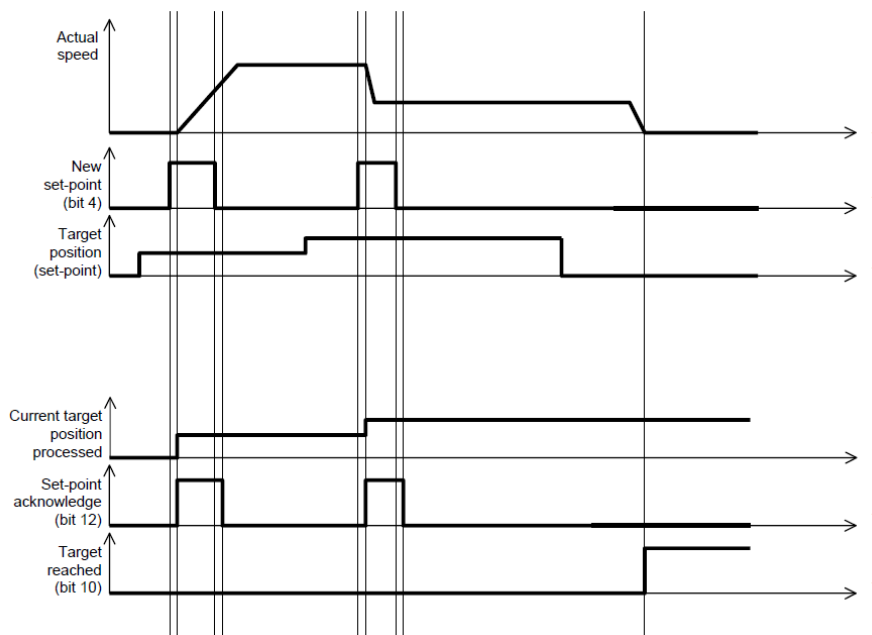

Multi-Step Setting Procedure

1. At first set NMT as Operational and control mode parameter (6061h) as 1.
2. At first the positioning data (**target_position: 607A_h**, **profile_velocity**, **end_velocity** and **profile_acceleration**) are transferred to the servo controller.
3. The host can start the positioning motion by setting the bit4 (**new_set_point**) in the **controlword** as 1, bit5 (**change_set_immediately**) as 0 and bit6 as absolute or referential type according to target position type (absolute or referential).
4. This will be acknowledged by the servo controller by setting the bit **set_point_acknowledge** in the **statusword** when the positioning data has been copied into the internal buffer. Motion could be started now.
5. Second positioning data (**target_position: 607A_h**, **profile_velocity**, **end_velocity** and **profile_acceleration**) are transferred to the servo controller.

6. The host can start the positioning motion by setting the bit4 (**new_set_point**) in the **controlword** as 1, bit5 (**change_set_immediately**) as 0 and bit6 as absolute or referential type according to target position type (absolute or referential).
7. When the 1 target is reached driver will move forward to second target position. When the second target position is reached drive will be acknowledged by bit10 (**target reached**) in status word. And then it will be executed by program or accept another new target position.

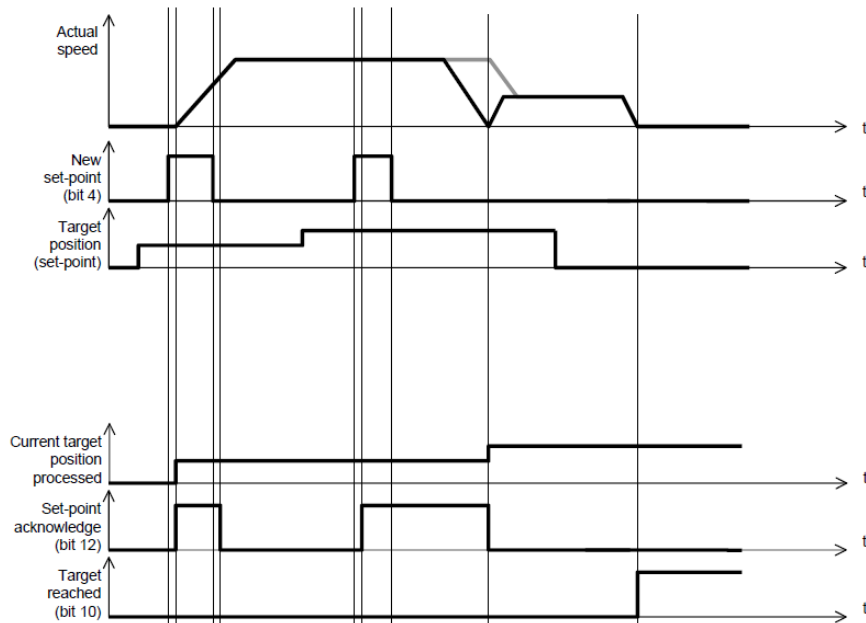

When the speed profile is S (motion_profile_type=2), only set of setpoints is available. 6083 h (profile_acceleration) limits max. acceleration. 6081h (profile_velocity) limits max.speed. 60A4-01 h (VAR Profile_jerk1) limits the jerk.now only symmetrical S linear is available.

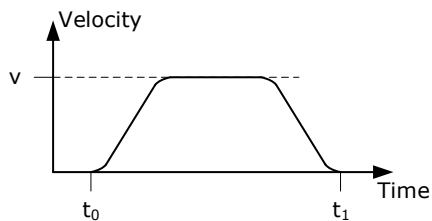

7.6 Interpolation Position Mode

7.6.1 Flow Diagram

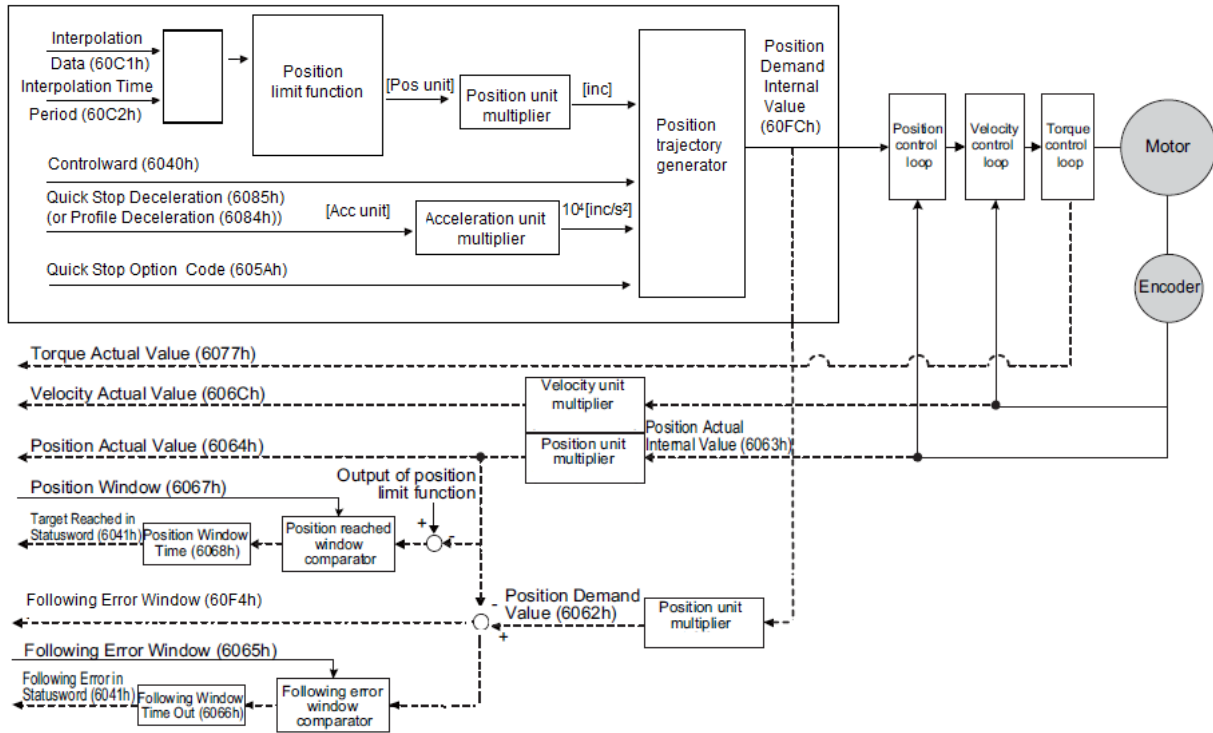

7.6.2 Control Word

15 ~ 9	8	7	6	5	4	3 ~ 0
*	Halt	*	*	*	Enable ip mode	*

*: referred to previous chapter

Name	Value	Description
Enable ip mode	0	Interpolated position mode inactive
	1	Interpolated position mode active
Halt	0	Execute the instruction of bit 4
	1	Stop axle

7.6.3 Status word

15 ~ 14	13	12	11	10	9 ~ 0
*	*	ip mode active	*	Target reached	*

*: referred to previous chapter

Name	Value	Description
Target reached	0	Halt = 0: Target position not (yet) reached Halt = 1: Axle decelerates

Name	Value	Description
	1	Halt = 0: Target position reached Halt = 1: Velocity of axle is 0
ip mode active	0	Interpolated position mode inactive
	1	Interpolated position mode active

7.6.4 Relevant Parameters

Index	Object	Name	Type	Attr.
60C0 h	VAR	Interpolation sub mode select	INT16	RW
60C1 h	ARRAY	Interpolation data record	INT32	RW
60C2 h	RECORD	Interpolation time period		RW

Interpolation sub mode select

Interpolation sub mode select is used to select the method of interpolation under IP control. Pronet servo drive only offers linear interpolation.

Index	60C0h
Name	Interpolation sub mode select
Object Code	VAR
Data Type	INT16
Access	RW
PDO Mapping	NO
Value Range	0
Default Value	0
Comment	0: Linear interpolation

Interpolation data record

Interpolation data record is used to reserve interpolation position data. Our servo drive's interpolation command only uses the first data whose subindex is 1.

Index	60C1h
Subindex	0
Object Code	ARRAY
Data Type	INT32
Access	RO
PDO Mapping	YES
Value Range	INT8
Default Value	2

Index	60C1h
Comment	number of entries

Index	60C1h
Subindex	1
Object Code	ARRAY
Data Type	INT32
Access	RW
PDO Mapping	YES
Value Range	INT32
Default Value	0
Comment	the first parameter of ip function

Index	60C1h
Subindex	2
Object Code	ARRAY
Data Type	INT32
Access	RW
PDO Mapping	YES
Value Range	INT32
Default Value	0
Comment	The second parameter of ip function

Interpolation time period

Interpolation time period is used to reserve the time data of interpolation position.

Index	60C2h
Object Code	RECORD
Data Type	Interpolation time period record (0080h)
Category	Conditional: mandatory if ip, csp, csv or cst mode is supported

Index	60C2h
Subindex	0
Object Code	RECORD
Data Type	UINT8
Access	C

Index	60C2h
PDO Mapping	NO
Value Range	02
Default Value	02
Comment	Highest sub-index supported

Index	60C2h
Subindex	01
Object Code	RECORD
Data Type	UINT8
Access	RW
PDO Mapping	YES
Value Range	UINT8
Default Value	01
Comment	Interpolation time period value

Index	60C2h
Subindex	02
Object Code	RECORD
Data Type	INT8
Access	RW
PDO Mapping	YES
Value Range	-128 to +63
Default Value	-3
Comment	Interpolation time index

7.6.5 Function description

Interpolation principle in IP mode

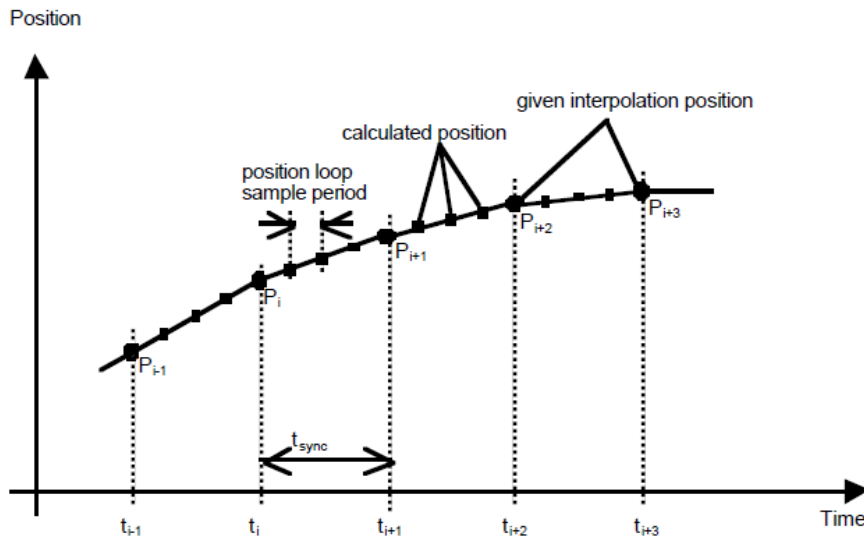

P_i : interpolation position set by the host

t_{sync} : sync period



NOTE

- In our servo drive, there is no buffer for position data so in IP control, all the position data needs to be updated by the controller. To achieve synchronization, controllers need to send the updated position at first and then use SYNC signal to make all the servo drive receive the synchronization information. After receiving the synchronization information, servo drive will synchronize its internal clock. Please notice that the sync period should be not bigger than interpolation cycle period in order to keep the updating of interpolation data.
- In IP mode, the host should at first set the servo's PDO receiving method into sync mode (Use SYNC frame to receive and send synchronization information). Because SYNC is broad casted, every servo drive will only update PDO data after receiving this signal.
- Before SYNC is sent, we need host to send position data X_i and control word to the servo drive.
- When there is data delay, servo drive will use the last sync date to do interpolation.
- After one sync period, if there is no further data updating, interpolation cycle overtime alarm (A 69) will happen. And then servo drive will stop.

Recommended RPDO configuration

- When you use only one RPDO,
 - Control word(index:6040h,subindex:0h)
 - 32bit position reference (index:60C1h,subindex:01h)
- When you use two RPDO
 - Control word(index:6040h,subindex:0h)
 - 32bit position reference (index:60C1h,subindex:01h)

Configuration process

1. Configure PDO. (RPDO1 is configured as index: 6040h, subindex: 0h, RPDO2 is configured as index 60c1h, subindex: 1h)
2. Set interpolation cycle time 2105h and 60C2, the unit is micro send (us). Please notice that both values need to be configured. For example, if the cycle time is 2ms, you need to set 2105h as 2000 and 60c2:01 as 2, 60c2:02 as -3.
3. Set sync cycle time (1006h), the unit is micro send (us)

4. Set PDO as Sync mode (Set the object dictionary (index: 1400h, subindex: 02h) as 1. Set object dictionary (index: 1401h, subindex: 02h) as 1). If sending PDO needs to be in sync mode as well, we need to set object dictionary (index: 1800h, subindex: 02h) as 1 and (index: 6060h, subindex: 0h) as 1 as well.
5. NMT starts node.

7.7 Torque limit Function

In CANopen bus mode, torque limit function is realized by 0x60E0 and 0x60E1 as below.

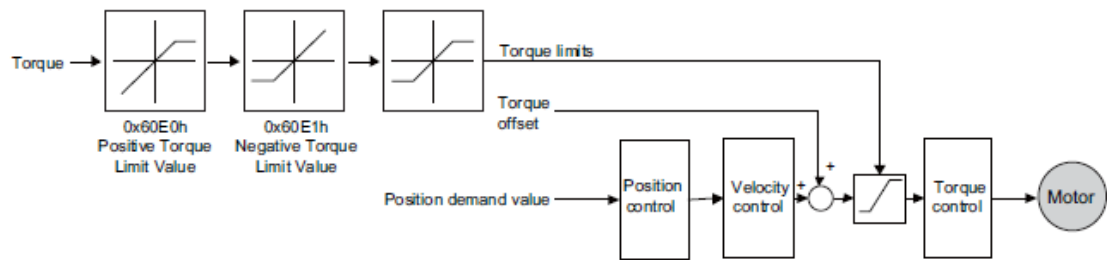

PosTorLimit(0x60E0)

PosTorLimit (0x60E0): positive torque limit, unit: 0.1% rated torque

Index	60E0h
Name	PosTorLimit
Object Code	VAR
Data Type	UINT16
Access	RW
PDO Mapping	YES
Value Range	0-3000
Default Value	3000

NegTorLimit(0x60E1)

NegTorLimit(0x60E1): negative torque limit, unit: 0.1% rated torque

Index	60E1h
Name	NegTorLimit
Object Code	VAR
Data Type	UINT16
Access	RW
PDO Mapping	YES
Value Range	0-3000
Default Value	3000

Chapter 8 CANopen Configuration Example

The entire test below is based on three conditions:

- Communication has been established correctly.
- The address of the servo drive is 1.
- All the message data is hexadecimal.

8.1 SDO configuration

SDO operation is to read and write parameters (0601h → host sends 0581h → slave sends)

Address: 3022h (Pn118) . Write 1000. And then read this parameter.

Activate the downloading process: 2B, 3022, 00, 03E8

- Message: 601(ID) 2B 22 30 00 E8 03 00 00
The servo drive should respond 60, 3022, 00, 00, 00, 00, 00
- Message: 581(ID) 60 22 30 00 00 00 00 00
Activate the uploading: 40, 3022, 00, 0000
- Message: 601(ID) 40 22 30 00 00 00 00 00
The servo drive needs to respond: 43, 3022, 00, 03E8
- Message: 581(ID) 43 22 30 00 E8 03 00 00

8.2 PDO Configuration

RPDO mapping example: To configure two RPDO, one of which is 6040h and the other are 607A and 6081h). The slaves respond of message 581h (ID) is omitted.

- RPDO 1 Mapping

```
601 (ID) 2F 00 16 00 00 00 00 00 //RPDO1 stop
First RPDO 201
601 (ID) 23 00 16 01 10 00 40 60 //6040h
601 (ID) 2F 00 16 00 01 00 00 00 // RPDO1 enable

601 (ID) 2F 01 16 00 00 00 00 00 //RPDO2 stop
```

- RPDO 2 Mapping

```
601 (ID) 23 01 16 01 20 00 7A 60 //607Ah and 6081h
601 (ID) 23 01 16 02 20 00 81 60
601 (ID) 2F 01 16 00 02 00 00 00 // RPDO2 enable
```

And then set the transmit PDO as SYNC or Timing method. The default setting is Time method.

After configuring the PDO, if you need to activate the configuration, you need to reset the communication.

```
NMT is OPERATIONAL: 00 01 01// (the first "01" is the start node instruction, the
second "01" is the number of the node)
```

8.3 Profile Position Mode

Step 1 At first, please mapping and configure PDO according to the example above and activate the communication.

Step 2 And then, please set the control mode.

```
message: 601(ID) 2F 60 60 00 01 00 00 00//set 6060h as 1 (position contrl is PP)
```

Step 3 And then, set status machine as Operation Enable

```
message: 601(ID) 2B 40 60 00 06 00 00 00//set 6040h as 6,switch to "ready to switch on"
message: 601(ID) 2B 40 60 00 07 00 00 00 //set 6040h as 7, switch to "switch on"
message: 601(ID) 2B 40 60 00 0F 00 00 00 //set 6040h as F, switch to "operation enable" and servo-on;
```



NOTE

This switching flow is based on successful switching received command and original state is "switch on disabled".

Step 4 And then, send data by PDO

Let servo motor rotate for 5 revolutions (Set PDO1 as 6040(status word), PDO2 as 607A (position pulse number) and 6081(velocity, unit as much as 0.1rpm)

Step 5 Send RPDO2 The data is as below

```
message: 301 (ID) 50 C3 00 00 2C 01 00 00(50000,300)// 50 C3 00 00 is position data, that is, 50000 pulses; 2C 01 00 00 is speed, that is, 30rpm;
```

Step 6 Send RPDO1 as below

```
message: 201(ID) 0F 00 //; Clear the bit4 of 6040 as 0.
message: 201(ID) 1F 00 // Clear the bit4 of 6040 as 1 and servo motor is operating under absolute position; Motor runs.
message: 201(ID) 0F 00 //Clear the bit4 of 6040.
message: 201(ID) 5F 00 // Clear the bit4 of 6040 as 1. The servo motor runs under incremental position.
message: 201(ID) 0F 00 //Clear bit4 of 6040 as 0.
```



NOTE

- The servo drive is using ↑of 6040's bit 4 to accept new position order. So after every single operation, the bit needs to be cleared. Host needs to check bit12 of status word 6040 in the servo drive to decide whether or not to give new data to servo systems. When status word 6041 in the servo drives 0, it means the servo drive is ready for new data and order. If the value is 1, the order won't be executed even if there is data for the servo drive to receive.
- In absolute approach, continuous position updating is required.
- If you want to change the operating distance, you need to send RPDO2 again.

---End

8.4 Two-axis interpolate position mode

Step 1 At first, mapping and configure PDO.

```
// receive 2 PDO by default: RPDO1: 60C1h--01h
// Send two PDO by default: TPDO1: 6041h TPDO2: 6064h/606Ch
// pulse, Velocity 0.1rpm
```

Step 2 Configure 1 RPDO

```
RPDO MAPPING
message: 601(ID) 2F 00 16 00 00 00 00 00 //RPDO1 stop
message: 601(ID) 23 00 16 01 20 01 C1 60 //60C1h,sub01
message: 601(ID) 2F 00 16 00 01 00 00 00// RPDO1 enable
```

Step 3 Configure 2 TPDO, TPDO1: 6041h TPDO2: 6064h/606Ch

```
TPDO MAPPING
message: 601(ID) 2F 00 1A 00 00 00 00 00 //TPDO1 stop
```

```

message: 601(ID) 23 00 1A 01 10 00 41 60 //6041h
message: 601(ID) 2F 00 1A 00 01 00 00 00 // TPDO1 enable

message: 601(ID) 2F 01 1A 00 00 00 00 //RPDO2 stop
message: 601(ID) 23 01 1A 01 20 00 64 60 //6064h and 606Ch
message: 601(ID) 23 01 1A 02 20 00 6C 60 //
message: 601(ID) 2F 01 1A 00 02 00 00 00// TPDO2 enable

```

Step 4 Set Sync time.

```

message: 601(ID) 2F C2 60 01 10 00 00 00 //60C2h-01----->1ms, set according to the
actual needs
message: 601(ID) 2F C2 60 02 FD 00 00 00 //

```

Step 5 Configure the PDO receiving and sending are both activated by one Sync frame.

- Set 1400h

```

message: 601(ID) 2F 00 14 02 01 00 00 00 //1400-02---->SYNC

```

- Set 1800h

```

message: 601(ID) 2F 00 18 02 01 00 00 00 //1800-02---->SYNC

```

- Set 1801h

```

message: 601(ID) 2F 01 18 02 01 00 00 00 //1801-02---->SYNC

```

Step 6 Set control mode

```

message: 601(ID) 2F 60 60 00 07 00 00 00//Set 6060h as7 ( IP position control)

```

Step 7 And then, set the status machine

```

message: 601(ID) 2B 40 60 00 06 00 00 00// Set 6040h as 6
message: 601(ID) 2B 40 60 00 07 00 00 00 // Set 6040h as 7
message: 601(ID) 2B 40 60 00 0F 00 00 00 // Set 6040h as F to servo on
message: 601(ID) 2B 40 60 00 1F 00 00 00 // Set 6040h as1F to IP_ACTIVE status;

```

Step 8 Activate the communicaiton

```

message: 00(ID) 01 01

```

Step 9 Setting the second axis is the same with the first axis.**Step 10 Host sends according to the setting of test SYNC cycle(1ms):**

```

message: 201(ID) 10 00 00 00 //16 P/R, interpolation potion data of the first axis
message: 202(ID) 20 00 00 00 //32 P/R, interpolation potion data of the second axis
message: 80(ID) // cycle to send SYNC according to interpolation cycle

```

Step 11 And then,drive returns

```

message: 181(ID) xx xx 00 00 //status word of the first axis
message: 182(ID) xx xx xx xx //position and speed of the first axis
message: 281(ID) xx xx 00 00 //status word of the second axis
message: 282(ID) xx xx xx xx //position and speed of the second axis

```

Sequence diagram is as following

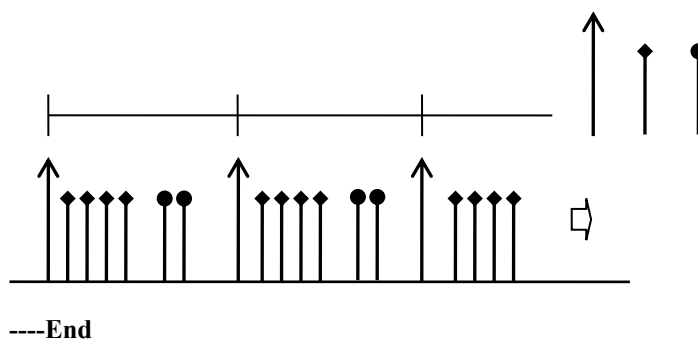

8.5 Homing

Step 1 Set the control mode as homing control.

```
message: 601(ID) 2F 60 60 00 06 00 00 00// Set the control mode as homing control.  
message: 601(ID) 2F 98 60 00 04 00 00 00//Use the fourth way to set the homing mode.
```

Step 2 Set the status machine

```
message: 601(ID) 2B 40 60 00 06 00 00 00  
message: 601(ID) 2B 40 60 00 07 00 00 00  
message: 601(ID) 2B 40 60 00 0F 00 00 00 //Servo On
```

Step 3 Send data through PDO. (Set PDO1 as 6040(status word). Set PDO2 as 607A (Position pulse number) and 6081. (Speed, unit 0.1rpm)
Set the homing method as 10rpm.

```
message: 601(ID) 23 99 60 02 64 00 00 00
```

Step 4 Homing is started.

```
message: 201 (ID) 1F 00
```

Cancel homing

```
Message: 201(ID) 0F 00
```

---End

Chapter 9 MODBUS Communication

9.1 RS-485 Wiring

ED3M model Servodrives provide the MODBUS communication function with RS-485 interface, which can be used to easily set parameters or to perform monitoring operations and so on.

The definitions of the Servodrive communication connector terminals (CN3 and CN4) are as follows.

Terminal No	Name	Description
1	–	Reserved
2	–	Reserved
3	485+	Terminal for RS-485 (+)
4	ISO_GND	Isolated ground
5	ISO_GND	Isolated ground
6	485-	Terminal for RS-485 (-)
7	CANH	Terminal for CAN (high-bit)
8	CANL	Terminal for CAN (low-bit)



NOTE

- The cable length shall be less than 100 meters in the environment of less interference. However, if the transmission speed needs to be 9600 bps or more, please use the cable within 15meters.
- Up to 31 Servodrives can be connected at the same time by using RS485, and a 120Ω of resistor needs to be connected to each terminal end. For connecting more devices into the network, please use a repeater to expand the number of connections.
- Always regard CN3 of Servodrive as the input terminal, and regard CN4 of Servodrive as the output terminal. That is, connect CN4 with CN3 of another Servodrive for expanding one slave station, and add a balance resistor to CN4 of the last Servodrive. It is strictly forbidden to connect CN3 of any two Servodrives.

For example, a network consists of one PLC and three of Servodrives A, B and C, the connection of them is shown in following figure.

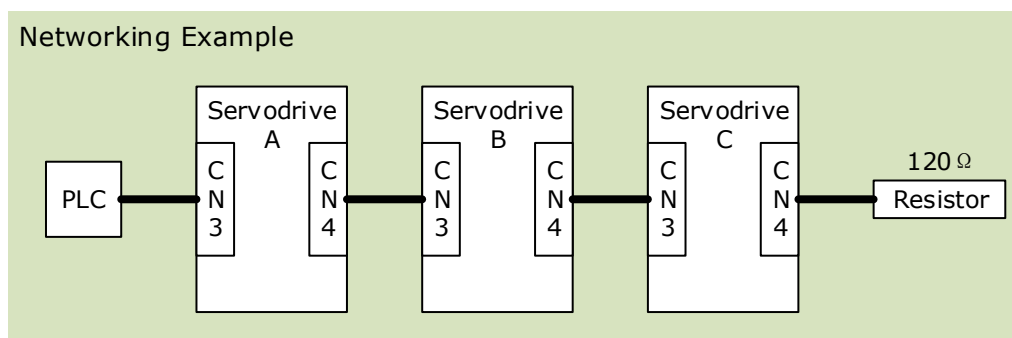

9.2 Relevant Parameters for MODBUS

No.	Description	When Enabled	Related Control		
			P	S	T
Pn700.0	Communication rate selection: [0] 4800bps [1] 9600bps [2] 19200bps [3] 38400bps [4] 57600bps [5] 115200bps	After restart	P	S	T
Pn700.1	Communication mode selection [0] 7, N, 2 (Modbus,ASCII) [1] 7, E, 1 (Modbus,ASCII) [2] 7, O, 1 (Modbus,ASCII) [3] 8, N, 2 (Modbus,ASCII) [4] 8, E, 1 (Modbus,ASCII) [5] 8, O, 1 (Modbus,ASCII) [6] 8, N, 2 (Modbus,RTU) [7] 8, E, 1 (Modbus,RTU) [8] 8, O, 1 (Modbus,RTU)	After restart	P	S	T
Pn700.2	Reserved	-	-	-	-
Pn700.3	Reserved	-	-	-	-
Pn701	Axis address in MODBUS	After restart	P	S	T

9.3 MODBUS Protocol

There are two modes for MODBUS communication: ASCII (American Standard Code for information interchange) mode and RTU (Remote Terminal Unit) mode.

9.3.1 Code Meaning

ASCII Mode

In Modbus ASCII, each data byte is split into the two bytes, representing the two ASCII characters in the Hexadecimal value. For example, the ASCII value '64' is represented as **3634** in hex, in which, ASCII value '6' is represented as 36_(H), and '4' is represented as 34_(H).

The range of data bytes in Modbus ASCII represent only the 16 hexadecimal characters. Therefore, every data byte in Modbus ASCII must be one of these 16.

ASCII	'0'	'1'	'2'	'3'	'4'	'5'	'6'	'7'
Hex	30 _(H)	31 _(H)	32 _(H)	33 _(H)	34 _(H)	35 _(H)	36 _(H)	37 _(H)
ASCII	'8'	'9'	'A'	'B'	'C'	'D'	'E'	'F'
Hex	38 _(H)	39 _(H)	41 _(H)	42 _(H)	43 _(H)	44 _(H)	45 _(H)	46 _(H)

RTU Mode

In Modbus RTU, each data byte (8-bit) consists of two 4-bit hexadecimal value. For example, the decimal data 100 can be represented as 64_(H) in RTU mode.

- Data Structure: 10-bit character form (for 7-bit data)

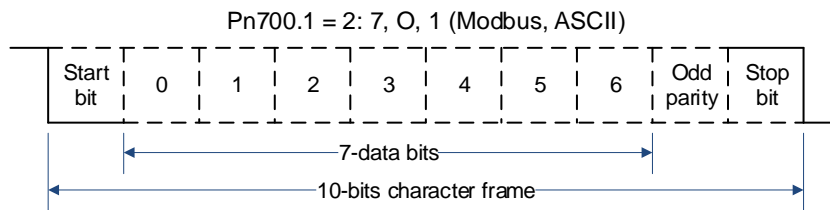
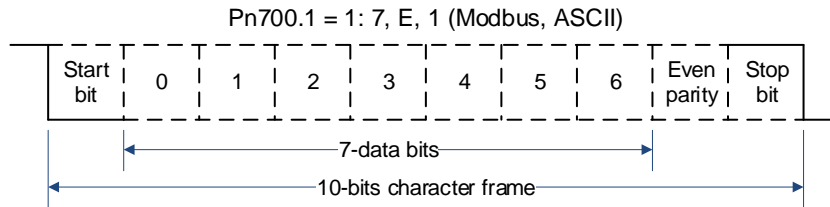
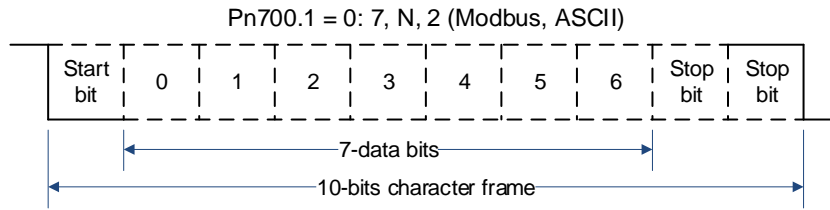

- Data Structure: 11-bit character form (for 8-bit data)

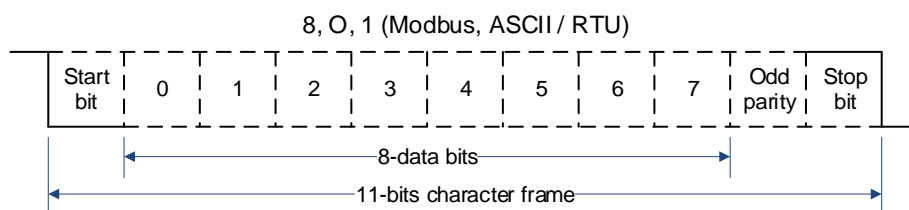
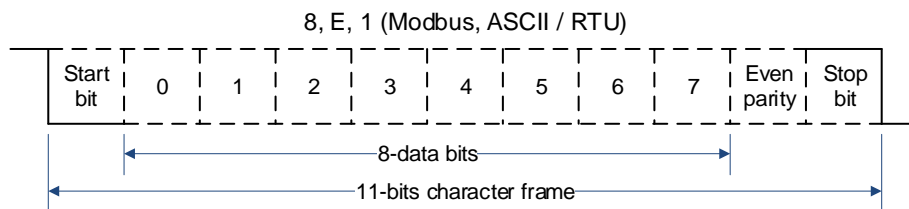
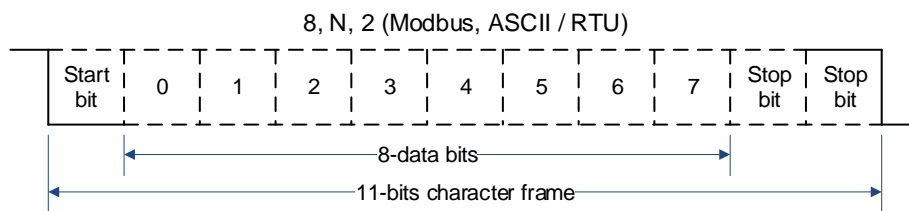

9.3.2 Data Format

ASCII Mode

STX	Starting character, which is from ‘:’ to (3A _H)
ADR	Communication address: 2 ASCII characters.
CMD	Command code: 2 ASCII characters.
DATA(n-1)	Data content: n word = 2n bytes = 4n ASCII characters, n is not greater than 12
.....	
DATA(0)	
LRC	Check code: 2 ASCII characters.
End 1	End code 1: (0D _H) (CR)
End 0	End code 1: (0A _H) (LF)

RTU Mode

STX	A static period for transferring 4 bytes at least.
ADR	Communication address: 1 byte
CMD	Command code: 1 byte
DATA(n-1)	Data content: n word = 2n bytes, n is not greater than 12
.....	
DATA(0)	
CRC	Check code: 1 byte
End 1	A static period for transferring 4 bytes at least.

Format Description

- STX (communication starting)
 - ASCII mode: character ‘:’
 - RTU mode: A static period for transferring 4 bytes at least.
- ADR (communication address)

A valid communication address is the range from 1 to 254.

For example, communicate with the Servodrive which address is 32 (20 in hex):

 - In ASCII mode: ADR=‘2’, ‘0’ → ‘2’=32_H, ‘0’=30_H
 - In RTU mode: ADR=20_H
- CMD (command code) and DATA

The format of the data depends on the command code. The common command code is shown as following:

Command code: 03_H, read N words, and N is not greater than 20.

For example, read 2 words starting from 0070_H from the servo drive which address is 01_H.

ASCII Mode			
Request information		Response information	
STX	“:”	STX	“:”
ADR	‘0’	ADR	‘0’
	‘1’		‘1’
CMD	‘0’	CMD	‘0’
	‘3’		‘3’
Data started address	‘0’	Number of Date (calculated by byte)	‘0’
	‘0’		‘4’
	‘7’	Data content of started address 0200 _H	‘0’
	‘0’		‘0’
Number of Date (calculated by word)	‘0’	Data content of address 0201 _H	‘0’
	‘0’		‘0’
	‘0’		‘0’
	‘2’		‘0’
LRC Check	‘8’	LRC Check	‘F’
	‘A’		‘8’
End 1	(0D _H)(CR)	End 1	(0D _H)(CR)
End 0	(0A _H)(LF)	End 0	(0A _H)(LF)

RTU Mode			
Request information		Response information	
ADR	01 _H	ADR	01 _H
CMD	03 _H	CMD	03 _H
Data started address	00 _H (high-bits)	Number of Date (calculated by byte)	04 _H
	70 _H (low-bits)		
Number of Date (calculated by word)	00 _H	Data content of started address 0200 _H	00 _H (high-bits)
	02 _H		00 _H (low-bits)
CRC Check (Low)	C5 _H (low-bits)	Data content of address 0201 _H	00 _H (high-bits)
CRC Check (High)	D0 _H (high-bits)		00 _H (low-bits)
		CRC Check (Low)	FA _H (low-bits)
		CRC Check (High)	33 _H (high-bits)

For another example, write 1 (0001_H) into 01_H servo address 0070_H. In which, the command code is 06_H, and write 1 word into.

ASCII Mode				
Request information		Response information		
STX	“:”	STX	“:”	
ADR	‘0’	ADR	‘0’	
	‘1’		‘1’	
CMD	‘0’	CMD	‘0’	
	‘6’		‘6’	
Data started address	‘0’	Number of Date (calculated by byte)	‘0’	
	‘0’		‘4’	
	‘7’		Data content of started address 0200 _H	‘0’
	‘0’			‘0’
Number of Date (calculated by word)	‘0’	Data content of address 0201 _H	‘7’	
	‘0’		‘0’	
	‘0’		‘0’	
	‘1’		‘1’	
LRC Check	‘8’	LRC Check	‘8’	
	‘8’		‘8’	
End 1	(0D _H)(CR)	End 1	(0D _H)(CR)	
End 0	(0A _H)(LF)	End 0	(0A _H)(LF)	

RTU Mode			
Request information		Response information	
ADR	01 _H	ADR	01 _H
CMD	06 _H	CMD	06 _H
Data started address	00 _H (high-bits)	Data started address	00 _H (high-bits)
	70 _H (low-bits)		70 _H (low-bits)
Date content	00 _H (high-bits)	Date content	00 _H (high-bits)
	01 _H (low-bits)		01 _H (low-bits)
CRC Check (Low)	49 _H (low-bits)	CRC Check (Low)	49 _H (low-bits)
CRC Check (High)	D1 _H (high-bits)	CRC Check (High)	D1 _H (high-bits)

Error Detection Value Calculation

- LRC check in ASCII mode

ASCII mode uses LRC (Longitudinal Redundancy Check) error detection value. The exceeded parts (e.g. the total value is 128_H of hex, then take 28_H only) is taken off by the unit of 256 in the total value from ADR to the last information, then calculate and compensate, the final result is LRC error detection value.

For example: read 1 word from 01_H servo address 0201_H

STX	‘:’
ADR	‘0’
	‘1’
CMD	‘0’
	‘3’
Data start address	‘0’
	‘2’
	‘0’
	‘1’
Number of Date (calculated by word)	‘0’
	‘0’
	‘0’
	‘1’
LRC Check	‘F’
	‘8’
End 1	(0D _H)(CR)
End 0	(0A _H)(LF)

Add from ADR data to the last data.

01_H+03_H+02_H+01_H+00_H+01_H=08_H

The compensate value is F8_H when 2 is used to compensate 08_H, so LRC is “F”, ”8”.

- **CRC check in RTU mode**

RTU mode uses CRC (Cyclical Redundancy Check) error detection value.

The process of CRC error detection value calculation is shown as follows:

Step 1: Load in a 16-bit register of FFFF_H, named “CRC” register.

Step 2: Run XOR calculation between the first bit (bit 0) of instruction information and 16-bit CRC register’s low bit (LSB), and the result is saved to CRC register.

Step 3: Check the lowest bit (LSB) of CRC register, if it is 0, CRC register moves one bit to right; if it is 1, CRC register moves one bit to right, then run XOR calculation with A001_H;

Step 4: Go to Step 5 till the third step has been executed for 8 times, otherwise return to Step 3.

Step 5: Repeat the steps from Step 2 to Step 4 for the next bit of instruction information, the comment of CRC register is the CRC error detection value while all the bits have been executed by the same way.

Example

After calculating out the CRC error detection value, the CRC low bit should be filled first in instruction information, and then fill the high bit of CRC. Please refer to the following example:

Read 2 words from the 0101_H address of 01_H servo. The final CRC register content calculated from ADR to the last bit of data is 3794_H, and then the instruction information is shown as follows.

Please be sure that 94_H is transmitted before 37_H.

ADR	01 _H
CMD	03 _H
Data start address	01 _H (high-bits)
	01 _H (low-bits)
Date number (calculated by word)	00 _H (hit-bits)
	02 _H (low-bits)
CRC check (low)	94 _H (low-bits)
CRC check (high)	37 _H (high-bits)
End 1	Completed the communication
End 0	

- **ASCII mode**
Communication is ended with (0DH) - [carriage return] and (0AH) - [new line].
- **RTU mode**
When the time exceeds the sleep interval by at least 4 bytes transmission time while in the current communication speed, it means the communication is finished.
- **Example**

The following example uses C language to generate CRC value. The function needs two parameters.

```

unsigned char * data;
unsigned char length;
// The function will return unsigned integer type CRC value.
unsigned int crc chk(unsigned char * data,unsigned char length){
    int i,j;
    unsigned int crc_reg=0xFFFF;
    While(length- -){
        crc_reg ^=*data++;
        for(j=0;j<8;j++){
            If(crc_reg & 0x01){
                crc_reg=( crc_reg >>1)^0xA001;
            }else{
                crc_reg=crc_reg >>1;
            }
        }
    }
    return crc_reg;
}

```

9.3.3 Communication Exception

Problems that occur during communication are a result of the following:

- Data address is incorrect while reading/writing parameters.
- The data is not within the parameter setting range while writing.
- Data transmission fault or checking code fault when communication is disturbed.

When the first and second communication faults occur, the servo drive is running normally, and will feed back an error frame.

When the third communication fault occurs, transmission data will be recognized as invalid to give up, and no error frame is returned.

The format of error frame:

Host controller data frame				
Start	Slave station address	Command	Data address,content	Check
-	-	[command]	-	-

Servo drive feeds back error frame				
Start	Slave station address	Response code	Error code	Check
-	-	[command] + 80 _H	-	-

Error frame responses code = [command]+80_H

- Error code =
- = 00_H: Normal communication
 - = 01_H: Servodrive cannot identify the required functions
 - = 02_H: The required data address does not exist in the servo drive
 - = 03_H: The required data in servo drive is not allowed. (exceeds the range of parameter)
 - = 04_H: Servodrive starts to perform the requirement, but cannot achieve it.

For example: Servo drive axis number is 03_H, write data 06_H into parameter Pn100 is not allowed, because the range of parameter Pn100 is 0 to 6. The servo drive will feedback an error frame, the error code is 03_H (Beyond the parameter's maximum value or minimum value).

Host controller data frame				
Start	Slave station address	Command	Data address,content	Check
-	03 _H	06 _H	0066 _H 1388 _H	-

Servo drive feedback error frame				
Start	Slave station address	Response code	Error code	Check
-	03 _H	86 _H	03 _H	-

Besides, if the data frame sent from host controller slave station address is 00_H, it determines the data to be broadcast data. The servo drives will not feed back any frames.

9.3.4 Data Communication Address in Servodrive

The communication parameter addresses are shown in the following table:

Address in Servodrive			Meaning	Description	Operation
Axis-A	Axis-B	Axis-C			
0000 to 0348	2000 to 2348	4000 to 4348	Parameter area	Corresponding parameters in parameter list	Read / Write
07F1 to 07FA	27F1 to 27FA	47F1 to 47FA	Alarm information memory area	10 of alarms historical record	Read only
07FD	27FD	47FD	Iu zero offset		Read only

Address in Servodrive			Meaning	Description	Operation
Axis-A	Axis-B	Axis-C			
07FE	27FE	47FE	Iv zero offset		Read only
0806 to 0816	2806 to 2816	4806 to 4816	Monitor data (corresponding with displayed data)		Read only
0806	2806	4806	Speed feedback	Unit: rpm	Read only
0809	2809	4809	Internal torque reference percentage	Relative rated torque	Read only
080A	280A	480A	Number of encoder rotation pulses		Read only
080B	280B	480B	Input signal state		Read only
080C	280C	480C	Encoder signal state		Read only
080D	280D	480D	Output signal state		Read only
080E	280E	480E	Pulse setting		Read only
080F	280F	480F	Low bits of present location	Unit:1 reference pulse	Read only
0810	2810	4810	High bits of present location	Unit: 10000 reference pulse	Read only
0811	2811	4811	Error pulse counter low 16 bits		Read only
0812	2812	4812	Error pulse counter high 16 bits		Read only
0813	2813	4813	Setting pulse counter low bits	Unit:1 reference pulse	Read only
0814	2814	4814	Setting pulse counter high bits	Unit:10000 reference pulses	Read only
0815	2815	4815	Load inertia percentage	%	Read only
0816	2816	4816	Servomotor overloading proportion	%	Read only
0817	2817	4817	Current alarm		Read only
0900	2900	4900	MODBUS communication IO signal	Reset when power off	Read / Write
090E			DSP version	Version is expressed by digit.	Read only
090F			CPLD version	Version is expressed by digit.	Read only
1021	3021	5021	Clear historical alarms	01:Clear	Write
1022	3022	5022	Clear current alarms	01:Clear	Write
1023	3023	5023	JOG fucntion	01: Enabled 00: Disabled	Read / Write

Address in Servodrive			Meaning	Description	Operation
Axis-A	Axis-B	Axis-C			
1024	3024	5024	Forward rotation in JOG	01: Start 00: Stop	Read / Write
1025	3025	5025	Reverse rotation in JOG	01: Start 00: Stop	Read / Write

- Parameter area (axis A is 0000 to 0348H, axis B is 2000 to 2348H, axis C is 4000 to 4348H)
Parameter address is relevant to the parameters in the parameter list.
For example, axis A parameter Pn000 is relevant to communication address 0000H; parameter Pn102 is relevant to communication address 0066H.
- Alarm information storage area (axis A is 07F1 to 07FAH, axis B is 27F1 to 27FAH, axis C is 47F1 to 47FAH)

Alarm No.	Description	Communication address
0	Historical alarm 1 (the latest alarm)	07F1 _H , 27F1 _H , 47F1 _H
1 to 8	Historical alarm 2 to 9	07F2 _H to 07F9 _H , 27F2 _H to 27F9 _H , 47F2 _H to 47F9 _H
9	Historical alarm 10 (the furthest alarm)	07FA _H , 27FA _H , 47FA _H

- Monitor data area (axis A is 0806 to 0816H, axis B is 2806 to 2816H, axis C is 4806 to 4816H)
The monitor data is corresponding to servo drive panel displays Un000 to Un016.
For example: the corresponding data of communication address 0807_H (speed setting) is FB16_H.
Therefore, the speed setting of axis A is -1258r/m.
- MODBUS communication IO signal
Use communication to control digital IO signal. This data will not be saved after power off.
It is operated with Pn512 as the communication input IO signal. That is to say, when the parameters setting in Pn512 enable the IO bit, the IO can be controlled by communication.
- Software version (090F_H)
Use digit to represent servo drive software version. For example, if the read out data is 0100_H, it means the software version is t-1.00.

Chapter 10 Specifications and Dimension

10.1 Servodrive Specifications

Servodrive Model		ED3M-1010AMA / ED3M-101010AMA			
Applicable Servomotor Model		EMJ-02A□□□□	EMJ-04A□□□□	EMJ-08A□□□□	EMJ-10A□□□□
		EMG-10A□□□□	EML-10A□□□□	-	-
Power Supply	Main Circuit	Three-phase, 200 VAC to 230VAC, -15% to +10%, 50 Hz or 60Hz			
	Control Circuit	Single-phase, 200 VAC to 230 VAC, -15% to +10%, 50 Hz or 60Hz			
Control Mode		SVPWM			
Feedback		Incremental Wire-saving type:2500 P/R Serial Encoder 131072P/R/1048576P/R			
Operating Conditions		Ambient/Storage Temperature	0 to 55°C/-20 to 85°C		
		Ambient/Storage Humidity	90% RH (with no condensation)		
		Vibration/Shock Resistance	Vibration Resistance: 4.9m/s ² , Impact Resistance: 19.6m/s ²		
Configuration		Base-mounted			
Speed Control	Speed Selection	Rotation Direction Selection	With /P-CON signal		
		Speed	Speed 1 to 7		
	Function	Soft Start Setting	0 to 10s (Can be set individually for acceleration and deceleration.)		
Position Control	Pulse Reference	Type	Sign + pulse train; CCW + CW pulse train; 90° phase difference 2-phase (phase A + phase B)		
		Form	Non-insulated line driver (about + 5V), open collector		
	Frequency	×1 multiplier: 4Mpps ×2 multiplier: 2Mpps ×4 multiplier: 1Mpps Open collector: 200Kpps Frequency will begin to decline when the duty ratio error occurs..			
Position Reference Setting	Position Setting	16 position nodes can be set.			
I/O Signals	Encoder Dividing Pulses Output		Phase-A, phase-B, phase-C, line driver output Number of dividing pulses: (1 to 16384)/16384		
	Sequence Input	Number of channels	3×8 channels		
		Function	Signal allocations and positive/negative logic modifications: Servo ON (/S-ON), P control (/P-CON), alarm reset (/ALM-RST), position error clear (/CLR), forward run prohibited (P-OT), reverse run prohibited (N-OT), forward current limit (/P-CL), reverse current limit (/N-CL) and so on.		
Sequence Output	Number of channels	3×4 channels			

	Function	Signal allocations and positive/negative logic modifications: Positioning completion(/COIN), speed coincidence(/V-CMP), servomotor rotation detection(/TGON), servo ready (/S-RDY), torque limit output(/CLT), brake interlock output (/BK), encoder C pulse(/PGC), Over travel/OT) and so on.
Internal Functions	Dynamic Brake	Each axis with dynamic brake function, which operated at main power OFF, servo alarm, servo OFF or overtravel.
	Protection Functions	Overcurrent, overvoltage, low voltage, overload, regeneration error, overspeed, etc.
	Utility Function	Alarm trace back, JOG operation, load inertia detection, etc.
	Communication Function	RS-485 communication port, MODBUS protocol, CAN communication port, CANopen protocol;
	Display Function	CHARGE × 1, power × 1, Axis LED × 3, 7-segment LEDS × 5, push button × 5

10.2 Servodrive Dimension

Unit: mm

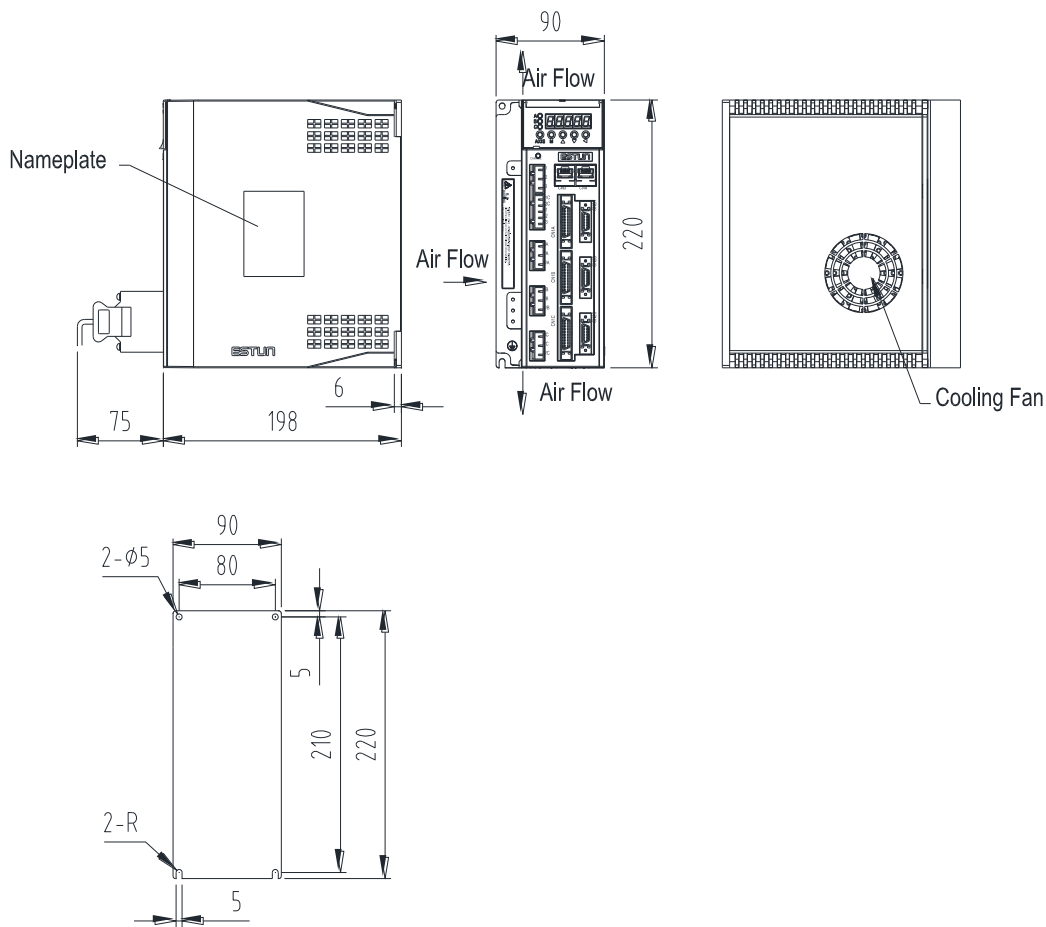

Appendix A Parameters List

A.1 Interpreting the Parameters List

"When Enabled" indicates the parameter take effective when:
 [After restart] the power supply is turned OFF and ON again.
 [Immediately] it was set.

"Related Control" indicates the parameter is valid in the control method of:
 [P] Position control
 [S] Speed control
 [T] Torque control

No.	Name	Range	Unit	Default	When Enabled	Related Control		
	Basic Function Selections	0000 to 1111	-	b0000	After restart	P	S	-
	0							
	b - - - □ Servo ON							
	0	Enabled.						
	1	Disabled. When turn S-RDY signal ON, the motor is excitation automatically.						
	b - - □ - Forward Drive Prohibit Input (P-OT)							
	0	Enabled. The motor is stopped according to the setting of Pn004.0 when the overtravel occurs.						
	1	Disabled.						
	b - □ - - Reverse Drive Prohibit Input (N-OT)							
	0	Enabled. The motor is stopped according to the setting of Pn004.0 when the overtravel occurs.						
	1	Disabled.						
	b □ - - - Reserved							

Parameter Number

Pn000

Here lists the value of the parameter and their description, in which, the sign [□] represents the corresponding value.

A.2 List of Servo Parameters

No.	Name	Range	Unit	Default	When Enabled	Related Control		
Pn000	Function Selections 0	0000 to 1111	-	0000	After restart	P	S	-
	b - - - □	Servo ON						
	0	Enabled.						
	1	Disabled. When turn S-RDY signal ON, the motor is excitation automatically.						
	b - - □ -	Forward Drive Prohibit Input (P-OT)						
	0	Enabled. The motor is stopped according to the setting of Pn004.0 when the overtravel occurs.						
	1	Disabled.						
	b - □ - -	Reverse Drive Prohibit Input (N-OT)						
	0	Enabled. The motor is stopped according to the setting of Pn004.0 when the overtravel occurs.						
	1	Disabled.						
b □ - - -	Reserved							
Pn001	Function Selections 1	0000 to 1111	-	0000	After restart	P	S	-
	b - - - □	Rotation Direction Selection						
	0	Use CCW as the forward direction.						
	1	Use CW as the forward direction.						
	b - - □ -	Reserved						
	b - □ - -	Reserved						
	b □ - - -	2nd electronic gear function (only valid for position control)						
	0	Disabled, regards /P-CON signal as P/PI switching.						
	1	Enabled, regards /P-CON signal as 2nd electronic gear switching. \						

No.	Name	Range	Unit	Default	When Enabled	Related Control		
	Function Selections 2	0000 to 1111	-	0010	After restart	P	S	-
Pn002	b - - - □ Electronic gear switching mode							
	0							
	1							
	Time sequence when Pn002.0=0 or 1							
Error time sequence:								
b - - □ - Reserved								
b - □ - - Reserved								
b □ - - - Reserved								

No.	Name	Range	Unit	Default	When Enabled	Related Control		
Pn003	Function Selections 3	0000 to 1111	-	0000	After restart	P	S	-
	b - - - □	Reserved						
	b - - □ -	Reserved						
	b - □ - -	Low speed compensation						
	0	Disabled.						
	1	Enabled. To enhance avoid servomotor creeping, but the degree of correction is determined by the setting in Pn219.						
	b □ - - -	Overload enhancement						
	0	Disabled.						
	1	Enabled. To enhance the overload capacity when servomotor exceeds the 2 times rated overload. It is used in frequent power ON/OFF occasions.						

No.	Name	Range	Unit	Default	When Enabled	Related Control		
	Function Selections 4	0000 to 3425	-	0000	After restart	P	S	-
Pn004	H - - - □ Stop Method							
	0	Stops the servomotor by applying DB and then releases DB.						
	1	Coast to a stop.						
	2	Stops the servomotor by DB when servo OFF, stops the servomotor by plug braking when overtravel, then places it into coast (power OFF) mode.						
	3	Makes the servomotor coast to a stop state when servo OFF, stops the servomotor by plug braking when overtravel, then places it into coast (power OFF) mode.						
	4	Stops the servomotor by DB when servo OFF, stops the servomotor by plug braking when overtravel, then places it into zero clamp mode.						
	5	Makes the servomotor coast to a stop state when servo OFF, stops the servomotor by plug braking when overtravel, then places it into zero clamp mode.						
	H - - □ - Error counter clear mode (only valid for position control)							
	0	Clear error pulse when S-OFF, not clear error pulse when overtravel.						
	1	Not clear error pulse						
	2	Clear error pulse When S-OFF or over travel						
	H - □ - - Reference pulse form (only valid for position control)							
	0	Sign + Pulse						
	1	CW + CCW						
	2	A + B (×1)						
	3	A + B (×2)						
	4	A + B (×4)						
	H□ - - - Inverses pulse (only valid for position control)							
	0	Do not inverse PULS reference and SIGN reference						
	1	Do not inverse PULS reference; Inverses SIGN reference.						
	2	Inverse PULS reference; Do not inverse SIGN reference						
	3	Inverse PULS reference and SIGN reference						

No.	Name	Range	Unit	Default	When Enabled	Related Control																
Pn005	Function Selections 5	0000 to 3351	-	0000	After restart	P	S	-														
	<table border="1"> <thead> <tr> <th colspan="2">H - - - □ Torque feedforward form</th> </tr> </thead> <tbody> <tr> <td>0</td> <td>Use general torque feedforward</td> </tr> <tr> <td>1</td> <td>Use high-speed torque feedforward</td> </tr> </tbody> </table>								H - - - □ Torque feedforward form		0	Use general torque feedforward	1	Use high-speed torque feedforward								
	H - - - □ Torque feedforward form																					
	0	Use general torque feedforward																				
	1	Use high-speed torque feedforward																				
	<table border="1"> <thead> <tr> <th colspan="2">H - - □ - Control method</th> </tr> </thead> <tbody> <tr> <td>0</td> <td>Speed control(Parameter reference) PCON is invalid.</td> </tr> <tr> <td>1</td> <td>Position control(pulse train reference) PCON: OFF, PI control; ON, P control</td> </tr> <tr> <td>2</td> <td>Speed control (contact reference) ↔ speed Control (zero reference) PCON, PCL, NCL: OFF Switches to position control (zero reference)</td> </tr> <tr> <td>3</td> <td>Speed control (contact reference) ↔ position control (pulse train reference) PCON, PCL, NCL: OFF Switches to position control(pulse train reference)</td> </tr> <tr> <td>4</td> <td>Position control (pulse train reference) ↔position control (INHIBIT) PCON: OFF, Position control (pulse train reference); ON, position control (INHIBIT)</td> </tr> <tr> <td>5</td> <td>Position control (contact reference) PCON: Used to change step; PCL, NCL: Used to search reference point or start</td> </tr> </tbody> </table>								H - - □ - Control method		0	Speed control(Parameter reference) PCON is invalid.	1	Position control(pulse train reference) PCON: OFF, PI control; ON, P control	2	Speed control (contact reference) ↔ speed Control (zero reference) PCON, PCL, NCL: OFF Switches to position control (zero reference)	3	Speed control (contact reference) ↔ position control (pulse train reference) PCON, PCL, NCL: OFF Switches to position control(pulse train reference)	4	Position control (pulse train reference) ↔position control (INHIBIT) PCON: OFF, Position control (pulse train reference); ON, position control (INHIBIT)	5	Position control (contact reference) PCON: Used to change step; PCL, NCL: Used to search reference point or start
	H - - □ - Control method																					
	0	Speed control(Parameter reference) PCON is invalid.																				
	1	Position control(pulse train reference) PCON: OFF, PI control; ON, P control																				
	2	Speed control (contact reference) ↔ speed Control (zero reference) PCON, PCL, NCL: OFF Switches to position control (zero reference)																				
	3	Speed control (contact reference) ↔ position control (pulse train reference) PCON, PCL, NCL: OFF Switches to position control(pulse train reference)																				
	4	Position control (pulse train reference) ↔position control (INHIBIT) PCON: OFF, Position control (pulse train reference); ON, position control (INHIBIT)																				
	5	Position control (contact reference) PCON: Used to change step; PCL, NCL: Used to search reference point or start																				
	<table border="1"> <thead> <tr> <th colspan="2">H - □ - - Out-of-tolerance alarm selection (only valid for position control)</th> </tr> </thead> <tbody> <tr> <td>0</td> <td>Disabled.</td> </tr> <tr> <td>1</td> <td>Enabled. An alarm occurs when the value of error counter exceeds Pn504.</td> </tr> <tr> <td>2</td> <td>Reserved</td> </tr> <tr> <td>3</td> <td>Reserved</td> </tr> </tbody> </table>								H - □ - - Out-of-tolerance alarm selection (only valid for position control)		0	Disabled.	1	Enabled. An alarm occurs when the value of error counter exceeds Pn504.	2	Reserved	3	Reserved				
	H - □ - - Out-of-tolerance alarm selection (only valid for position control)																					
	0	Disabled.																				
	1	Enabled. An alarm occurs when the value of error counter exceeds Pn504.																				
	2	Reserved																				
	3	Reserved																				
	<table border="1"> <thead> <tr> <th colspan="2">H□ - - - Servomotor model selection</th> </tr> </thead> <tbody> <tr> <td>0</td> <td>EMJ</td> </tr> <tr> <td>1</td> <td>EMG</td> </tr> <tr> <td>2</td> <td>EML</td> </tr> <tr> <td>3</td> <td>Reserved</td> </tr> </tbody> </table>								H□ - - - Servomotor model selection		0	EMJ	1	EMG	2	EML	3	Reserved				
	H□ - - - Servomotor model selection																					
0	EMJ																					
1	EMG																					
2	EML																					
3	Reserved																					

No.	Name	Range	Unit	Default	When Enabled	Related Control		
Pn006	Function Selections 6	0000 to 2203	-	0000	After restart	P	S	T
	H - - - □	Bus type selection						
	0	No bus						
	1	Reserved						
	2	Reserved						
	3	CANopen						
	H - - □ -	Reserved						
	H - □ - -	Low-frequency vibration suppression switch						
	0	Low-frequency vibration suppression function disabled						
	1	Speed low-frequency vibration suppression function enabled						
2	Position low-frequency vibration suppression function enabled							
Pn007	Function Selections 7	0000 to 1111	-	0000	After restart	P	S	T
	b - - - □	Width of C-pulse						
	0	Standard width of C pulse						
	1	Wider the width of C pulse						
	b - - □ -	Reserved						
	b - □ - -	Reserved						
	b □ - - -	Torque filter						
	0	Standard torque filter						
	1	New type torque filter						

No.	Name	Range	Unit	Default	When Enabled	Related Control			
Pn009	Function Selections 9	0000 to 0100	-	0000	After restart	P	-	-	
	b - - - □	Reserved							
	b - - □ -	Reserved							
	b - □ - -	Electronic gear selection							
		0	16 bits electronic gear						
	1	32 bits electronic gear							
	b□ - - -	Reserved							
Pn010	Function Selections 10	0000 to 0001	-	0001	After restart	P	S	T	
	H - - - □	Automatic identification of motor selection							
		0	Disabled.						
		1	Enabled. The drive, motor and encoder models are automatically acquired and the corresponding servo parameters are automatically loaded.						
		H - - □ -	Reserved						
	H - □ - -	Reserved							
	H□ - - -	Reserved							

No.	Name	Range	Unit	Default	When Enabled	Related Control			
Pn100	Turning method	0000 to 0006	-	0000	After restart	P	S	-	
	H - - - <input type="checkbox"/> Turning Method Selection								
		0	Manual Turning						
		1	Perform automatic tuning of conventional load with no-change in inertia						
		2	Perform automatic tuning of conventional load with less change in inertia						
		3	Perform automatic tuning of conventional load with more change in inertia						
		4	Perform automatic tuning of vertical load with no-change in inertia						
		5	Perform automatic tuning of vertical load with less change in inertia						
		6	Perform automatic tuning of vertical load with more change in inertia						
		H - - <input type="checkbox"/> - Reserved							
	H - <input type="checkbox"/> - - Reserved								
	H <input type="checkbox"/> - - - Reserved								
Pn101	Machine rigidity setting	0 to 15	-	5	Immediately	P	S	-	
	The response speed of servo system is determined by this parameter. Normally, the rigidity should be set a little larger. However, if it is too large, it would suffer mechanical impact. It should be set a little smaller when large vibration is present. This parameter is only valid in autotuning.								
Pn102	Speed loop gain	1 to 4000	Hz	300	Immediately	P	S	-	
	This parameter determines speed loop gain.								
Pn103	Speed loop integral time constant	1 to 4096	0.25ms	80	Immediately	P	S	-	
	Decreases the value of this parameter to shorten positioning time and enhance speed response.								
Pn104	Position loop gain	0 to 1000	1/s	40	Immediately	P	-	-	
	This parameter determines position loop gain. Decreases this value to enhance servo rigidity, but vibration will occur if the value is too large.								
Pn105	Torque reference filter time constant	0 to 250	0.25ms	2	Immediately	P	S	-	
	Torque reference filter can eliminate or lighten mechanical vibration, but incorrect setting will result to mechanical vibration.								
Pn106	Load inertia percentage	0 to 20000	%	0	Immediately	P	S	-	
	Setting value = (load inertia/rotor inertia) × 100								

No.	Name	Range	Unit	Default	When Enabled	Related Control		
Pn107	2nd speed loop gain	1 to 4000	Hz	320	Immediately	P	S	-
	The meanings of these parameters are the same as Pn102. This parameters is only needed to set when two types of gain function are enabled.							
Pn108	2nd speed loop integral time constant	1 to 4096	0.25ms	40	Immediately	P	S	-
	The meanings of these parameters are the same as Pn103. This parameters is only needed to set when two types of gain function are enabled.							
Pn109	2nd position loop gain	0 to 1000	Rad/s	40	Immediately	P	-	-
	The meanings of these parameters are the same as Pn104. This parameters is only needed to set when two types of gain function are enabled.							
Pn110	2nd torque reference filter time constant	0 to 250	0.25ms	2	Immediately	P	S	-
	The meanings of these parameters are the same as Pn105. This parameters is only needed to set when two types of gain function are enabled.							
Pn111	Speed bias	0 to 300	rpm	0	Immediately	P	-	-
	<p>This parameter setting can shorten positioning time. However, if it is too large or does not cooperate with Pn111 correctly, vibration will occur.</p> <p>The relationship with speed reference, error counter, positioning error is shown in the following chart.</p>							
Pn112	Feedforward	0 to 100	%	0	Immediately	P	-	-
	It is used to set position feedforward. The response speed is faster and position error is less when this parameter setting is higher. Vibration will occur if the value is set too large.							
Pn113	Feedforward filter	0 to 640	0.25ms	0	Immediately	P	-	-
	It is used to ease mechanical vibration due to position feedforward. The feedforward lag will be enlarged and result to vibration if the value is set too large.							

No.	Name	Range	Unit	Default	When Enabled	Related Control		
Pn114	Torque feedforward	0 to 100	%	0	Immediately	P	S	-
	It is used to set torque feedforward, and enhance response speed. Set the load inertia percentage (Pn106) correctly to enable this function in manual gain adjustment mode.							
Pn115	Torque feedforward filter	0 to 640	0.25ms	0	Immediately	P	S	-
	It is used to ease mechanical vibration due to torque feedforward.							
Pn116	P/PI switching condition	0 to 4	-	4	After restart	P	S	-
	0	Torque reference percentage						
	1	Value of offset counter						
	2	Value of acceleration speed setting						
	3	Value of speed setting						
	4	Fixed PI						
Pn117	Torque switching threshold	0 to 300	%	200	Immediately	P	S	-
	Threshold of torque to switch PI control to P control.							
Pn118	Offset counter switching threshold	0 to 10000	1 Pulse	0	Immediately	P	-	-
	Threshold of error counter to switch PI control to P control.							
Pn119	Setting acceleration speed switching threshold	0 to 3000	10 rpm/s	0	Immediately	P	S	-
	Threshold of acceleration speed to switch PI control to P control.							
Pn120	Setting speed switching threshold	0 to 10000	rpm	0	Immediately	P	S	-
	Threshold of speed to switch PI control to P control.							
Pn121	Gain switching condition	0 to 8	-	0	After restart	P	S	-
	0	Fix to 1st group gain						
	1	External switch gain switching (G-SEL)						
	2	Torque percentage						
	3	Value of offset counter						
	4	Value of acceleration speed setting (10rpm)						
	5	Value of speed setting						
	6	Speed reference input						
	7	Actual motor speed						
	8	Pn123 + Pn124						

No.	Name	Range	Unit	Default	When Enabled	Related Control		
Pn122	Switching delay time	0 to 20000	0.25ms	0	Immediately	P	S	-
	Delay time of switching gain when switching condition is satisfied.							
Pn123	Switch threshold level	0 to 20000	-	0	Immediately	P	S	-
	Gain switching trigger level							
Pn124	Reserved							
Pn125	Position gain switching time	0 to 20000	0.25ms	0	Immediately	P	-	-
	This parameter is used to smooth transition if the change of the two groups of gain is too large.							
Pn126	Hysteresis switching	0 to 20000	-	0	Immediately	P	S	-
	This parameter is used to set the operation hysteresis of gain switching.							
Pn127	Low speed detection filter	0 to 100	0.25ms	10	Immediately	P	S	-
	This parameter is used to filter in low speed detection. The speed detection will be lagged if the value is too large.							
Pn128	Speed gain acceleration relationship during online autotuning	0 to 3	-	3	Immediately	P	S	-
	The increasing multiple of speed loop gain is the same rigidity during online autotuning. The speed loop gain is larger when this value is higher.							
Pn129	Low speed correction coefficient	0 to 30000	-	0	Immediately	P	S	-
	The intensity of anti-friction and anti-creeping at low speed. Vibration will occur if this value is set too large.							
Pn130	Friction Load	0 to 3000	0.1%	0	Immediately	P	S	-
	Friction load or fixed load compensation							
Pn131	Friction compensation speed hysteresis area	0 to 100	rpm	0	Immediately	P	S	-
	Threshold of friction compensation start							
Pn132	Sticking friction load	0 to 1000	0.1%/1000rpm	0	Immediately	P	S	-
	Sticking damp which is in direct proportion to speed.							
Pn200	PG divided ratio	16 to 16384	1 Pulse	16384	After restart	P	S	-
	Analog encoder output orthogonal difference pulses. The meaning of this value is the number of analog encoder output orthogonal difference pulses per one servomotor rotation.							

No.	Name	Range	Unit	Default	When Enabled	Related Control		
Pn201	1st electronic gear numerator	1 to 65535	–	1	After restart	P	–	–
	<p>The electronic gear enables the reference pulse to relate with the servomotor travel distance, so the host controller doesn't change the mechanical deceleration ratio and encoder pulses. In fact, it is the setting of frequency doubling or frequency division to the reference pulses.</p> $\frac{\text{Numerator (Pn201 or Pn203)}}{\text{Denominator (Pn202)}}$							
Pn202	Electronic gear denominator	1 to 65535	–	1	After restart	P	–	–
	To employ by combining with Pn201.							
Pn203	2nd electronic gear numerator	1 to 65535	–	1	After restart	P	–	–
	Same with the meaning of Pn201.							
Pn204	Position reference acceleration/deceleration time constant	0 to 32767	0.25ms	0	Immediately	P	–	–
	This value is used to smooth the input pulses. The effect of smoothness is better when the value is higher, but lag will occur if the value is too large.							
Pn205	Position reference filter form selection	0 to 1	–	0	After restart	P	–	–
	0	1st order filter						
	1	2nd order filter						

No.	Name	Range	Unit	Default	When Enabled	Related Control			
Pn206	Pluse input selection	0000 to 0033	-	0000	After restart	P	-	-	
	H - - - <input type="checkbox"/> Pluse input port selection								
		0	Use pluse input themselves						
		1	Use A-axis pluse input port						
		2	Use B-axis pluse input port						
		3	Use C-axis pluse input port						
	H - - <input type="checkbox"/> - Synchronize selection								
		0	A-axis and B-axis use the same pluse input port setted by Pn206.0, C-axis use C-axis pluse input port						
		1	A-axis and C-axis use the same pluse input port setted by Pn206.0, B-axis use B-axis pluse input port						
		2	B-axis and C-axis use the same pluse input port setted by Pn206.0, A-axis use A-axis pluse input port						
	3	A-axis, B-axis and C-axis use the same pluse input port							
H - <input type="checkbox"/> - - Reserved									
H <input type="checkbox"/> - - - Reserved									
Pn304	Parameter speed	-6000 to 6000	rpm	500	Immediately	-	S	-	
	The parameter can be set to positive or negative. When control mode is set to D, it determines the speed of motor.								
Pn305	JOG speed	0 to 6000	rpm	500	Immediately	-	S	-	
	It is used to set JOG rotation speed, and the direction is determined by the pressing key during JOG operation.								
Pn306	Soft start acceleration time	0 to 10000	ms	200	Immediately	-	S	-	
	The time for trapeziform acceleration to accelerate to 1000rpm.								
Pn307	Soft start deceleration time	0 to 10000	ms	200	Immediately	-	S	-	
	The time for trapeziform deceleration to decelerate to 1000rpm.								
Pn308	Speed filter time constant	0 to 10000	ms	0	Immediately	-	S	-	
	1st order filter time constant								
Pn309	S curve risetime	0 to 10000	ms	0	Immediately	-	S	-	
	The time for transition from one point to another point in S curve.								

No.	Name	Range	Unit	Default	When Enabled	Related Control			
Pn310	Speed reference curve form	0 to 3	-	0	After restart	-	S	-	
		0	Slope						
		1	S curve						
		2	1st order filter						
		3	2nd order filter						
Pn311	S form selection	0 to 3	-	0	Immediately	-	S	-	
	This value determines the transition form of S curve.								
Pn316	Internal speed 1	-6000 to 6000	rpm	100	Immediately	-	S	-	
	Internal speed is enabled when Pn005.1=3, 4, 5, 6								
	Input signal			operating speed					
	/P-CON	/PCL	/NCL						
	OFF(H)	OFF(H)	OFF(H)	Zero speed or switch to other control modes					
		OFF(H)	ON(L)	Internal speed 1					
		ON(L)	OFF(H)	Internal speed 2					
		ON(L)	ON(L)	Internal speed 3					
	ON(L)	OFF(H)	OFF(H)	Internal speed 4					
		OFF(H)	ON(L)	Internal speed 5					
		ON(L)	OFF(H)	Internal speed 6					
ON(L)		ON(L)	Internal speed 7						
Pn317	Internal speed 2	-6000 to 6000	rpm	200	Immediately	-	S	-	
	See the description of Pn316.								
P318	Internal speed 3	-6000 to 6000	rpm	300	Immediately	-	S	-	
	See the description of Pn316.								
Pn319	Internal speed 4	-6000 to 6000	rpm	-100	Immediately	-	S	-	
	See the description of Pn316.								
Pn320	Internal speed 5	-6000 to 6000	rpm	-200	Immediately	-	S	-	
	See the description of Pn316.								
Pn321	Internal speed 6	-6000 to 6000	rpm	-300	Immediately	-	S	-	
	See the description of Pn316.								

No.	Name	Range	Unit	Default	When Enabled	Related Control		
Pn322	Internal speed 7	-6000 to 6000	rpm	500	Immediately	-	S	-
	See the description of Pn316.							
Pn401	Forward torque internal limit	0 to 350	%	300	Immediately	P	S	-
	Servomotor output torque limit value .(depending on the actual overload capacity).							
Pn402	Reverse torque internal limit	0 to 350	%	300	Immediately	P	S	-
	Servomotor output torque limit value .(depending on the actual overload capacity).							
Pn403	Forward external torque limit	0 to 300	%	100	Immediately	P	S	-
	Servomotor output torque limit value .(depending on the actual overload capacity).							
Pn404	Reverse external torque limit	0 to 300	%	100	Immediately	P	S	-
	Servomotor output torque limit value .(depending on the actual overload capacity).							
Pn405	Plug braking torque limit	0 to 300	%	300	Immediately	P	S	-
	Servomotor output torque limit value .(depending on the actual overload capacity).							
Pn406	Speed limit during torque control	0 to 6000	rpm	1500	Immediately	-	-	T
	Speed limit during torque control.							
Pn407	Notch filter 1 frequency	50 to 2000	Hz	2000	Immediately	P	S	-
	<ul style="list-style-type: none"> • In some conditions, vibration will be picked up and response will be lagged after notch filter is set. • When notch filter frequency is set to 5000, the notch filter is invalid. 							
Pn408	Notch filter 1 depth	0 to 11	-	1	Immediately	P	S	-
	-							
Pn409	Notch filter 2 frequency	50 to 2000	Hz	2000	Immediately	P	S	-
	-							
Pn410	Notch filter 2 depth	0 to 11	-	1	Immediately	P	S	-
	-							
Pn411	Low frequency vibration frequency	50 to 500	0.1Hz	100	Immediately	P	S	-
	Frequency of low frequency vibration with load.							

No.	Name	Range	Unit	Default	When Enabled	Related Control		
Pn412	Low frequency vibration damp	0 to 200	–	25	Immediately	P	S	–
	Attenuation damp of low frequency vibration with load. It does not need to change.							
Pn413	Torque control delay time	1 to 2000	0.25ms	100	Immediately	–	–	T
	–							
Pn414	Torque control speed hysteresis	10 to 1000	rpm	50	Immediately	–	–	T
	–							
Pn500	Positioning error	0 to 5000	1 Pulse	100	Immediately	P	–	–
	Outputs /COIN signal when error counter is less than this value.							
Pn501	Coincidence difference	0 to 100	rpm	10	Immediately	P	–	–
	Outputs /VCMP signal when the difference between speed reference value and speed feedback value is less than this value.							
Pn502	Zero clamp speed	0 to 3000	rpm	10	Immediately	P	–	–
	A position loop is created and the Servomotor remains stopped at a position reference of 0 when the corresponding speed of the input analog signal less than this setting. (The current stop position is held.)							
Pn503	Rotation detection speed TGON	0 to 3000	rpm	20	Immediately	P	S	–
	When the servomotor speed exceeds this parameter setting value, it means that the servomotor has already rotated steadily and outputs /TGON signal.							
Pn504	Offset counter overflow alarm	1 to 32767	256 Pulses	1024	Immediately	P	–	–
	When the value in error counter exceeds this parameter setting value, it means that error counter alarm has occurred and outputs alarm an signal.							
Pn505	Servo ON waiting time	-2000 to 2000	ms	0	Immediately	P	S	–
	<p>Parameters Pn505, Pn506, Pn507 and Pn508 are only enabled when the port output parameters are allocated with /BK signal output.</p> <p>These parameters are used to keep braking (prevent from gravity glissade or continuous outside force on servomotor) time sequence.</p> <ul style="list-style-type: none"> • For the parameter is plus,/BK signal is output firstly when servo-ON signal is input, and then servomotor excitation signal is created after delaying the parameter setting time. • For the parameter is minus, servomotor excitation signal is output firstly when servo-ON signal is input, and then /BK signal is created after delaying the parameter setting time. 							
Pn506	Basic waiting flow	0 to 500	10ms	10	Immediately	P	S	–
	<p>Standard setting: /BK output (braking action) and servo-OFF are at the same time.</p> <p>At present, the machine movable part may shift slightly due to gravity according to mechanical configuration and character; it can be eliminated by using the parameters when the servomotor is at stop or at a low speed.</p>							

No.	Name	Range	Unit	Default	When Enabled	Related Control			
Pn507	Brake waiting speed	10 to 100	rpm	100	Immediately	P	S	-	
	The /BK signal is output when the servomotor speed is decreased below the parameter setting value at servo-OFF.								
Pn508	Brake waiting time	10 to 100	10ms	50	Immediately	P	S	-	
	The /BK signal is output when the delay time exceeds the parameter setting value after servo-OFF. The /BK signal is output as long as either of the brake waiting speed or brake waiting time is satisfied.								
Pn509	Input signals allocation 1	0000 to EEEE	-	3210	After restart	P	S	-	
	H - - - <input type="checkbox"/> Allocate signal to CN1 <input type="checkbox"/> -10								
		0	/S-ON						
		1	/P-CON						
		2	P-OT						
		3	N-OT						
		4	ALMRST						
		5	/CLR						
		6	/PCL						
		7	/NCL						
		8	/G-SEL						
		9	/JDPOS-JOG+						
		A	/JDPOS-JOG-						
		B	/JDPOS-HALT						
		C	HmRef						
		D	SHOME						
		E	ORG(ZPS)						
H - - <input type="checkbox"/> - Allocate signal to CN1 <input type="checkbox"/> -11									
0 to E: same as the allocation of CN1 <input type="checkbox"/> -10.									
H - <input type="checkbox"/> - - Allocate signal to CN1 <input type="checkbox"/> -12									
0 to E: same as the allocation of CN1 <input type="checkbox"/> -10.									
H <input type="checkbox"/> - - - Allocate signal to CN1 <input type="checkbox"/> -13									
0 to E: same as the allocation of CN1 <input type="checkbox"/> -10.									

No.	Name	Range	Unit	Default	When Enabled	Related Control			
Pn510	Input signals allocation 2	0000 to EEEE	-	7654	After restart	P	S	-	
	H - - - □ Allocate signal to CN1□-14								
	0		/S-ON						
	1		P-CON						
	2		P-OT						
	3		N-OT						
	4		ALMRST						
	5		/CLR						
	6		/PCL						
	7		/NCL						
	8		/G-SEL						
	9		/JDPOS-JOG+						
	A		/JDPOS-JOG-						
	B		/JDPOS-HALT						
	C		Reserved						
D		SHOME							
E		ORG(ZPS)							
H - - □ - Allocate signal to CN1□-15									
0 to E: same as the allocation of CN1□-14.									
H - □ - - Allocate signal to CN1□-16									
0 to E: same as the allocation of CN1□-14.									
H □ - - - Allocate signal to CN1□-17									
0 to E: same as the allocation of CN1□-14.									

No.	Name	Range	Unit	Default	When Enabled	Related Control			
Pn511	Output signals allocation	0000 to 0999	-	0210	After restart	P	S	-	
	H - - - □	Allocate signal to CN1□-7, -8							
		0	/COIN(/VCMP)						
		1	/TGON						
		2	/S-RDY						
		3	/CLT						
		4	/BK						
		5	PGC						
		6	OT						
		7	/RD						
		8	/HOME						
		9	/TCR						
		H - - □ -	Allocate signal to CN1□-1, -2						
			0 to 9: same as the allocation of CN1□-7, 8.						
		H - □ - -	Allocate signal to CN1□-5, -6						
		0 to 9: same as the allocation of CN1□-7, 8.							
	H□ - - -	Reserved							

No.	Name	Range	Unit	Default	When Enabled	Related Control				
Pn512	Bus control input node low-bit enabled	0000 to 1111	-	0000	Immediately	P	S	-		
	b - - - □ CN1□-10 in bus selection									
	0		Disabled							
	1		Enabled							
	b - - □ - CN1□-11 in bus selection									
	0		Disabled							
	1		Enabled							
	b - □ - - CN1□-12 in bus selection									
	0		Disabled							
	1		Enabled							
	b□ - - - CN1□-13 in bus selection									
	0		Disabled							
	1		Enabled							
	Pn513	Bus control input node high-bit enabled	0000 to 1111	-	0000	Immediately	P	S	-	
		b - - - □ CN1□-14 in bus selection								
		0		Disabled						
1		Enabled								
b - - □ - CN1□-15 in bus selection										
0		Disabled								
1		Enabled								
b - □ - - CN1□-16 in bus selection										
0		Disabled								
1		Enabled								
b□ - - - CN1□-17 in bus selection										
0		Disabled								
1		Enabled								

No.	Name	Range	Unit	Default	When Enabled	Related Control		
Pn514	Input port filter	0 to 1000	0.2ms	1	Immediately	P	S	-
	It is used to set input port filter time. The signal will be lagged if the parameter setting is too high.							
Pn515	Alarm port filter	0 to 3	0.2ms	1	Immediately	P	S	-
	It is used to set alarm filter time. The signal will be lagged if the parameter setting is too high							
Pn516	Input signal inversion 1	0000 to 1111	-	0000	Immediately	P	S	-
	b - - - □ CN1□-10 inverse selection							
	0		Do not inverse					
	1		Inverse					
	b - - □ - CN1□-11 inverse selection							
	0		Do not inverse					
	1		Inverse					
	b - □ - - CN1□-12 inverse selection							
	0		Do not inverse					
	1		Inverse					
	b □ - - - CN1□-13 inverse selection							
	0		Do not inverse					
	1		Inverse					

No.	Name	Range	Unit	Default	When Enabled	Related Control			
Pn517	Input signal inversion 2	0000 to 1111	-	0000	Immediately	P	S	-	
	b - - - □ CN1□-14 inverse selection								
	0		Do not inverse						
	1		Inverse						
	b - - □ - CN1□-15 inverse selection								
	0		Do not inverse						
	1		Inverse						
	b - □ - - CN1□-16 inverse selection								
	0		Do not inverse						
	1		Inverse						
	b □ - - - CN1□-17 inverse selection								
	0		Do not inverse						
	1		Inverse						
	Pn518	Dynamic brake time	50 to 2000	0.5ms	125	Immediately	P	S	-
	-								
	Pn519	Reserved	-	-	-	-	-	-	-
Pn520	Position complete time	0 to 60000	0.25ms	200	Immediately	P	-	-	
	-								
Pn521	Reserved	-	-	-	-	-	-	-	
Pn522	Reserved	-	-	-	-	-	-	-	
Pn523	Reserved	-	-	-	-	-	-	-	
Pn524	Reserved	-	-	-	-	-	-	-	
Pn525	Overload alarm threshold	100 to 150	%	100	Immediately	P	S	-	
	When load percentage is larger than overload alarm threshold, A04 will occur soon. Pn525 is recommended to set below 120, otherwise the servo drive and motor will be damaged.								

No.	Name	Range	Unit	Default	When Enabled	Related Control		
Pn526	Reserved	-	-	-	-	-	-	-
Pn527	Reserved	-	-	-	-	-	-	-
Pn528	Output signal inversion	0000 to 1111	-	0000	Immediately	P	S	-
	b - - - □ CN1□-3, 4 inverse selection							
	0	Do not inverse						
	1	Inverse						
	b - - □ - CN1□-7, 8 inverse selection							
0	Do not inverse							
1	Inverse							
b - □ - - CN1□-1, 2 inverse selection								
0	Do not inverse							
1	Inverse							
b □ - - - CN1□-5, 6 inverse selection								
0	Do not inverse							
1	Inverse							
Pn529	Torque detection output signal threshold value	3 to 300	%	100	Immediately	P	S	T
	When motor torque output is higher than Pn529 setting value,/TCR is ON. When motor torque output is lower than Pn529 setting value,/TCR is OFF.							
Pn530	Torque detection output signal time	1 to 1000	ms	100	After restart	P	S	T
	Torque detection output signal time.							
Pn600	JPOS0 Position pulse in point to point control	-9999 to 9999	10000 Pulses	0	Immediately	P	-	-
	The two parameters Pn600 and Pn601 are used in combination, and the algebraic sum of them is the position JPOS0 needs to reach. (The number of servomotor rotation revolutions is related with the programme mode of point to point control.)							
Pn601	JPOS0 Position pulse in point to point control	-9999 to 9999	1 Pulse	0	Immediately	P	-	-
	See the description of Pn600.							

No.	Name	Range	Unit	Default	When Enabled	Related Control		
Pn602 to Pn631	Position pulse in point to point control from JPOS1 to JPOS15.							
Pn632	JPOS0 Point to point speed control	0 to 6000	rpm	500	Immediately	P	-	-
	-							
Pn633 to Pn647	Point to point speed control from JPOS0 to JPOS15.							
Pn648	JPOS0 Point to point 1st order filter	0 to 32767	0.25ms	0	Immediately	P	-	-
	1st order filter time of JPOS0 point to point control can stop or start the servomotor mildly.							
Pn649 to Pn663	Point to point 1st order filter from JPOS1 to JPOS15.							
Pn664	JPOS0 point to point control stop time	0 to 300	50ms	10	Immediately	P	-	-
	-							

No.	Name	Range	Unit	Default	When Enabled	Related Control				
Pn665 to Pn679	Point to point control stop time from JPOS1 to JPOS15.									
Pn680	Reserved	–	–	–	–	–	–	–		
Pn681	Function selection 681	0000 to 0133	–	0000	Immediately	P	–	–		
	H – – – □ Single/cyclic, start/reference point selection									
	0	Cyclic operation, PCL start signal, NCL search reference point in forward direction.								
	1	Single operation, PCL start signal, NCL search reference point in forward direction.								
	2	Cyclic operation, NCL start operation, PCL search reference point in forward direction.								
	3	Single operation, NCL start operation, PCL search reference point in forward direction.								
	H – – □ – Change step and start mode									
	0	Delay to change step, no need of start signal, delay to start after S-ON.								
	1	PCON change step, no need of start signal, PCON delay to start after S-ON, but inside pulse can not stop when PCON off.								
	2	Delay to change step, need start signal, canceling start signal can immediately stop inside pulse. Return to programme start point process step when reset.								
	3	PCON change step, need start signal, canceling start signal can immediately stop inside pulse. Return to programme start point process step when reset.								
	H – □ – – Change step input signal mode									
	0	Change step input signal electrical level mode								
	1	Change step input signal pulse mode								
	H □ – – – Reserved									
Pn682	Programming mode	0 to 1	–	0	Immediately	P	–	–		
	0	Incremental programming								
	1	Absolute programming								
Pn683	Programming start step	0 to 15	–	0	Immediately	P	–	–		
	Select the start point of the point to point control									
Pn684	Programming stop step	0 to 15	–	1	Immediately	P	–	–		
	Select the stop point of the point to point control.									

No.	Name	Range	Unit	Default	When Enabled	Related Control		
Pn685	Speed during searching reference position	0 to 3000	rpm	1500	Immediately	P	-	-
	-							
Pn686	Speed during leaving reference position	0 to 200	rpm	30	Immediately	P	-	-
	-							
Pn687	Position teaching pulse	-9999 to 9999	10000 Pulses	0	Immediately	P	-	-
	The two parameters Pn687 and Pn688 are used in combination, and the algebraic sum of them is the current position of position teaching. When performing the position teaching by utility function, the algebraic sum of the two parameters are given to the current position							
Pn688	Position teaching pulse	-9999 to 9999	1 Pulse	0	Immediately	P	-	-
	See the description of Pn687.							
Pn689	Homing Mode Setting	0000 to 0111	-	0000	After restart	P	-	-
	b - - - □ Homing Mode							
	0		Homing in the forward direction					
	1		Homing in the reverse direction					
	b - - □ - Search C-Pulse Mode							
	0		Return to search C-Pulse when homing					
	1		Directly search C-Pulse when homing					
	b - □ - - Homing trigger starting mode							
	0		Disabled					
	1		Homing triggered by SHOM signal (rising edge)					
b□ - - - Reserved								
Pn690	Number of error pulses during homing	0 to 9999	10000 Pulses	0	Immediately	P	-	-
	-							
Pn691	Number of error pulses during homing	0 to 9999	1 Pulse	0	Immediately	P	-	-
	-							

No.	Name	Range	Unit	Default	When Enabled	Related Control			
Pn692	Reserved	-	-	-	-	-	-	-	
Pn693	Reserved	-	-	-	-	-	-	-	
Pn694	Reserved	-	-	-	-	-	-	-	
Pn700	MODBUS Setting	0000 to 0182	-	0151	After restart	P	S	-	
	H - - - <input type="checkbox"/> MODBUS communication baud rate								
		0	4800bps						
		1	9600bps						
		2	19200bps						
		3	38400bps						
		4	57600bps						
		5	115200bps						
	H - - <input type="checkbox"/> - MODBUS protocol selection								
		0	7, N, 2 (Modbus,ASCII)						
	1	7, E, 1 (Modbus,ASCII)							
	2	7, O, 1 (Modbus,ASCII)							
	3	8, N, 2 (Modbus,ASCII)							
	4	8, E, 1 (Modbus,ASCII)							
	5	8, O, 1 (Modbus,ASCII)							
	6	8, N, 2 (Modbus,RTU)							
	7	8, E, 1 (Modbus,RTU)							
	8	8, O, 1 (Modbus,RTU)							
H - <input type="checkbox"/> - - Reserved									
H <input type="checkbox"/> - - - Reserved									
Pn701	MODBUS Axis address	1 to 247	-	1	After restart	P	S	-	
	Axis address of MODBUS protocol communication								

No.	Name	Range	Unit	Default	When Enabled	Related Control			
Pn702	Reserved	-	-	-	-	-	-	-	
Pn703	CAN communication speed	0000 to 0015	-	0004	After restart	P	S	-	
	H - - - <input type="checkbox"/> CAN communication baud rate								
		0	50Kbps						
		1	100Kbps						
		2	125Kbps						
		3	250Kbps						
	4	500Kbps							
	5	1Mbps							
H - - <input type="checkbox"/> - Reserved									
H - <input type="checkbox"/> - - Reserved									
H <input type="checkbox"/> - - - Reserved									
Pn704	CAN communication contact	1 to 127	-	1	After restart	P	S	-	
	CANopen Aix address of communication								
Pn705	32 bits 1st electronic gear numerator (H)	0 to 9999	-	0	After restart	P	S	T	
	<p>The parameters are valid,when Pn009.2=1.</p> <p>The electronic gear enables the reference pulse to relate with the servomotor travel distance, so the host controller doesn't change the mechanical deceleration ratio and encoder pulses. In fact, it is the setting of frequency doubling or frequency division to the reference pulses.</p> $\frac{\text{Numerator } (Pn705 \times 10000 + Pn706 \text{ or } Pn709 \times 10000 + Pn710)}{\text{Denominator } (Pn707 \times 10000 + Pn708)}$								
Pn706	32 bits 1st electronic gear numerator (L)	0 to 9999	-	1	After restart	P	S	T	
	See the description of Pn705.								
Pn707	32 bits electronic gear denominator (H)	0 to 9999	-	0	After restart	P	S	T	
	See the description of Pn705.								
Pn708	32 bits electronic gear denominator (L)	0 to 9999	-	1	After restart	P	S	T	
	See the description of Pn705.								

No.	Name	Range	Unit	Default	When Enabled	Related Control			
Pn709	32 bits 2nd electronic gear numerator (H)	0 to 9999	-	0	After restart	P	S	T	
	See the description of Pn705.								
Pn710	32 bits 2nd electronic gear numerator (L)	0 to 9999	-	1	After restart	P	S	T	
	See the description of Pn705.								
Pn840	Encoder Function	0003 to 0F3F	-	0003	After restart	P	S	-	
	H - - - □ Encoder model selection								
		0	Reserved						
		1	Reserved						
		2	Reserved						
		3	17 bits absolute encoder						
		4	Reserved						
		5	Reserved						
		6	Wire-saving incremental encoder (2500P/R)						
		7	Reserved						
		8	20 bits incremental encoder						
	9	20 bits absolute encoder							
H - - □ - Motor designing sequence									
	0	EM□-□□□□A							
	1	EM□-□□□□B							
H - □ - - Power level of Machine									
	0	200W							
	1	400W							
	2	750W							
	3	1000W							
	E	50W							
	F	100W							
H□ - - - Reserved									

Appendix B Alarms List

Alarm No.	Output	Alarm Name	Description
A. 01	×	Parameter breakdown	The checksum results of parameters are abnormal.
A. 03	×	Overspeed	The servomotor speed is excessively high and the servomotor is out of control.
A. 04	×	Overload	The servomotor is operating continuously under a torque largely exceeding ratings.
A. 05	×	Position error counter overflow	Internal counter overflow
A. 06	×	Position error pulse overflow	Position error pulse exceeded parameter (Pn504)
A. 07	×	The setting of electronic gear or given pulse frequency is not reasonable.	The setting of electronic gear is not reasonable or the given pulse frequency is too high.
A. 08	×	The 1st channel of current detection is wrong.	Something wrong with the inside chip of the 1st channel.
A. 09	×	The 2nd channel of current detection is wrong.	Something wrong with the inside chip of the 2nd channel.
A. 10	×	Incremental Encoder is break off.	At least one of Incremental Encoder PA,PB,PC is broken off.
A. 12	×	Overcurrent	An overcurrent flowed through the IPM.
A. 13	×	Overvoltage	Main circuit voltage for servomotor rotation is excessively high.
A. 14	×	Undervoltage	Main circuit voltage for servomotor rotation is excessively low.
A. 15	×	Bleeder resistor error	Bleeder resistor is faulty.
A. 16	×	Regeneration error	Regenerative circuit error
A. 20	×	Power line phase shortage	One phase does not bring into main circuit power supply.
A. 25	×	Motor power line U over current	Mechanical stuck or motor power line U phase sequence is wrong
A. 26	×	Motor power line V over current	Mechanical stuck or motor power line V phase sequence is wrong
A. 27	×	Motor power line W over current	Mechanical stuck or motor power line W phase sequence is wrong
A. 38	×	Photosensitive component of the encoder error	Photoelectric encoder was damaged.
A. 39	×	EEPROM in the encoder error	Encoder was damaged.
A. 42	×	Servomotor model error	The parameter setting of servo drive does not match the servomotor.
A. 43	×	Servo drive type error	The parameter setting of servo drive does not match the servomotor.
A. 45	×	Absolute encoder multiturn information error	Absolute encoder multiturn information is faulty.
A. 46	×	Absolute encoder multiturn information overflow	Absolute encoder multiturn information overflow.

Alarm No.	Output	Alarm Name	Description
A. 47	×	Battery voltage below 2.5V	Absolute encoder multiturn information is lost.
A. 48	×	Battery voltage below 3.1V	Battery voltage is too low.
A. 50	×	Serial encoder communication overtime	Encoder disconnected; encoder signal disturbed; encoder error or encoder decoding circuit error.
A. 51	×	Absolute encoder overspeed alarm detected	Absolute encoder multiturn information may be faulty. Error reasons: 1. The battery is not connected or the battery voltage is insufficient. 2. The power supply to servo drive is not turned ON when the battery voltage is normal, or the servomotor running acceleration is too high due to external reason.
A. 52	×	Absolute state of serial encoder error	Encoder or the encoder decoding circuit is faulty.
A. 53	×	Serial encoder calcaution error	Encoder or the encoder decoding circuit is faulty.
A. 54	×	Parity bit or end bit in serial encoder control domain error	Encoder signal is disturbed or the encoder decoding circuit is faulty.
A. 55	×	Serial encoder communication data checking error	Encoder signal is disturbed or the encoder decoding circuit is faulty.
A. 56	×	End bit in serial encoder control domain error	Encoder signal is disturbed or the encoder decoding circuit is faulty.
A. 58	×	Serial encoder data empty	The EEPROM data of serial encoder is empty.
A. 59	×	Serial encoder data format error	The EEPROM data format of serial encoder is incorrect.
A. 66	×	CAN communication abnormal	CAN communication is faulty because of abnormal communication connection or disturbance.
A. 67	×	Receiving heartbeat timeout	The master station sends heartbeat time timeout.
A. 68	×	CAN Synchronization frame interval is too short	The filling time and the cycle of the synchronous frame does not match or communication is faulty.
A. 69	×	CAN Synchronization frame interval is too long	The filling time and the cycle of the synchronous frame does not match or communication is faulty.
A. 00	○	Not an error	Normal operation status.

○: Output transistor is ON; ×: Output transistor is OFF.

Appendix C Object dictionary

Index	Subindex	Object	Name	Type	Attr.	PDO	Support						Unit
							All	IP	PP	PV	PT	HM	
2	--	VAR	od_integer8	INT8	RW	YES	•						
3	--	VAR	od_integer16	INT16	RW	YES	•						
4	--	VAR	od_integer32	INT32	RW	YES	•						
5	--	VAR	od_unsigned8	UINT8	RW	YES	•						
6	--	VAR	od_unsigned16	UINT16	RW	YES	•						
7	--	VAR	od_unsigned32	UINT32	RW	YES	•						
1000	--	VAR	device_type	UINT32	RO	NO	•						
1001	--	VAR	error_register	UINT8	RO	NO	•						
1003	--	VAR	pre_defined_error_field	UINT8	RW	NO	•						
1005	--	VAR	cob_id_sync	UINT32	RW	NO	•						
1006	--	VAR	communication_cycle_period	UINT32	RW	NO	•						
1007	--	VAR	synchronous_window_length	UINT32	RW	NO	•						
1014	--	VAR	cob_id_emergency_message	UINT32	RW	NO	•						
1016	--	ARRAY	consumer_heartbeat_time	--	--	--	•						
	0		number_of_entries	UINT8	RO	NO	•						
	1		consumer_heartbeat_time1	UINT32	RW	NO	•						
1017		VAR	producer_heartbeat_time	UINT16	RW	NO	•						
1018	--	RECORD	identity_object	--	--	--	•						
	0		number_of_entries	UINT8	RO	NO	•						
	1		vendor_id	UINT32	RO	NO	•						
	2		product_code	UINT32	RO	NO	•						
	3		revision_number	UINT32	RO	NO	•						
	4		serial_number	UINT32	RO	NO	•						
1029	--	ARRAY	error_behaviour	--	--	--	•						
	0		number_of_entries	UINT8	RO	NO	•						
	1		communication_error	UINT8	RW	NO	•						
1200	--	RECORD	server_sdo_parameter	--	--	--	•						
	0		number_of_entries	UINT8	RO	NO	•						
	1		cob_id_client_server	UINT32	RO	NO	•						
	2		cob_id_server_client	UINT32	RO	NO	•						
1400	--	RECORD	receive_pdo_parameter_rpdo1	--	--	--	•						
	0		number_of_entries_rpdo1	UINT8	RO	NO	•						
	1		cob_id_used_by_pdo_rpdo1	UINT32	RO	NO	•						
	2		transmission_type_rpdo1	UINT8	RW	NO	•						
1401	--	RECORD	receive_pdo_parameter_rpdo2	--	--	--	•						
	0		number_of_entries_rpdo2	UINT8	RO	NO	•						

Index	Subindex	Object	Name	Type	Attr.	PDO	Support						Unit
							All	IP	PP	PV	PT	HM	
	1		cob_id_used_by_pdo_rpdo2	UINT32	RO	NO	•						
	2		transmission_type_rpdo2	UINT8	RW	NO	•						
1402	--	RECORD	receive_pdo_parameter_rpdo3	--	--	--	•						
	0		number_of_entries_rpdo3	UINT8	RO	NO	•						
	1		cob_id_used_by_pdo_rpdo3	UINT32	RO	NO	•						
	2		transmission_type_rpdo3	UINT8	RW	NO	•						
1403	--	RECORD	receive_pdo_parameter_rpdo4	--	--	--	•						
	0		number_of_entries_rpdo4	UINT8	RO	NO	•						
	1		cob_id_used_by_pdo_rpdo4	UINT32	RO	NO	•						
	2		transmission_type_rpdo4	UINT8	RW	NO	•						
1600	--	RECORD	receive_pdo_mapping_rpdo1	--	--	--	•						
	0		number_of_entries	UINT8	RO	NO	•						
	1		first_mapped_object_rpdo1	UINT32	RW	NO	•						
	2		second_mapped_object_rpdo1	UINT32	RW	NO	•						
	3		third_mapped_object_rpdo1	UINT32	RW	NO	•						
	4		fourth_mapped_object_rpdo1	UINT32	RW	NO	•						



南京埃斯顿自动控制技术有限公司

地址: 南京江宁经济技术开发区水阁路16号 邮编: 211106

电话: 025-52785866

传真: 025-52785576

公司主页: www.estun.com

电子信箱: info@estun.com



www.estun.com

ESTUN